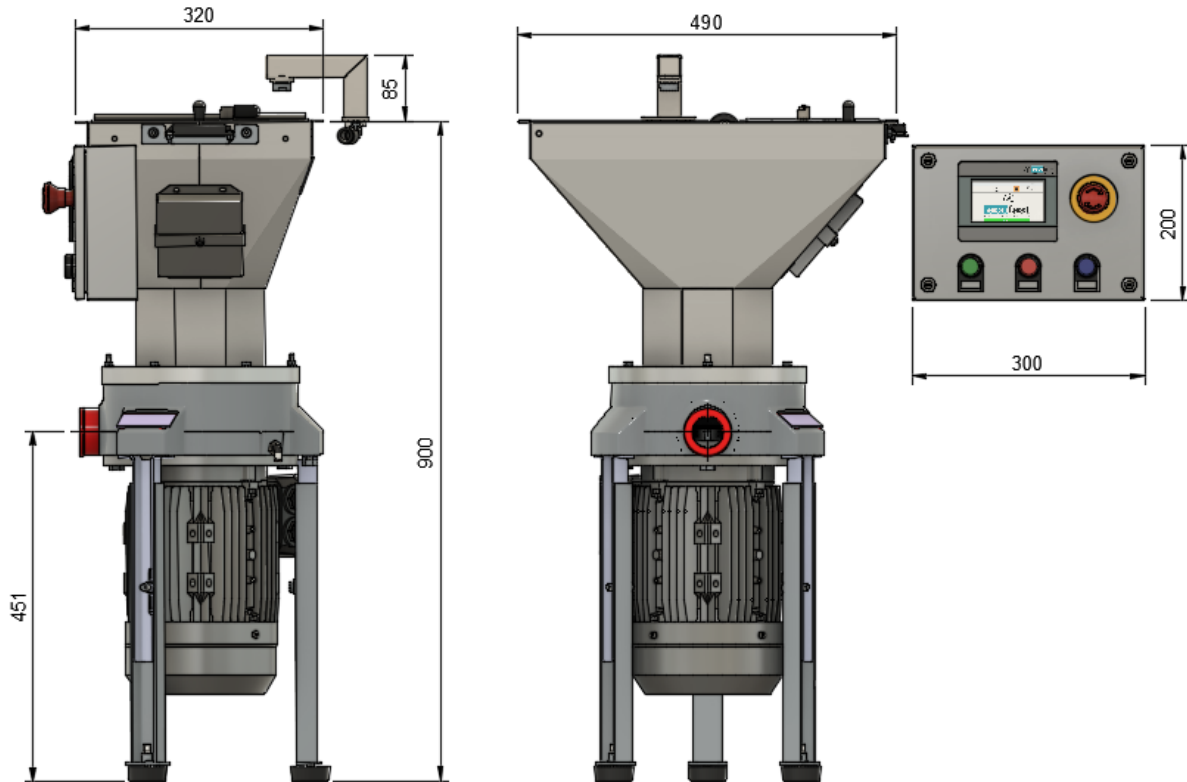

**Model # - D390 Macerator**

D390 – Remote Dewaterer - Mark III Food Waste Dehydra	(DxWxH)
	543x416x900
Water connections – 1 x Cold water for cleaning system only	15mm with ¾ standard hose connections with 3 bar pressure
Water Consumption (flow rate) <b>Cold Water</b>	9 to 11 litres per minute
Air-break as standard	Option for no air-break
Water connection height (mm)	645
Discharge height (mm)	450
Discharge size (mm & inches)	50 / 2"
Capacity (Food Waste) per minute / hour (kg)	13 / 800
Weight (kg)	70
Decibels (dB)	77
Electrical Phase	3
Motor voltage (v)	380-415
Motor frequency (Hz)	50
Motor kilowatt (kW)	2.2
Amps	16
Options	Cutlery saver
Electrical Connection	Flying leads to be wired to Ecofast dewaterer control system
Can be connected to	D600, D610, T400
Operator control panel	Required to be mounted within 1 meter of the operator