



MTL Series



*High-Speed Doors for
Material – Transport – Logistics*

High-speed doors for logistics



Versatility as a concept

The newly developed EFA-SRT® MTL door has been designed for all applications within intensive logistics processes and is particularly suitable for both commercial and industrial use in closed areas that are not exposed to wind and/or weather conditions.

With a large number of applications, equipment and combination options, the high-speed roll-up door (SRT) spans all conceivable areas in the eponymous product portfolio “Material – Transport – Logistics” (MTL).

MTL series Wealth of variants as a programme

The advantages of the EFA-SRT® MTL high-speed roll-up door at a glance:

- Power-driven high-speed roll-up door for industrial and commercial use in the materials handling sector
- Flexible and modular design
- Particularly suitable for confined space applications
- Variable end elements
- Maximum speed up to 1.5 m/s
- Various different door curtain designs
- Up to 250,000 cycles per year
- A maximum of 6 cycle times per minute
- Sizes up to approx. 3,000 x 3,000 mm



EFA-SRT® MTL access restriction without personnel traffic (FTO)

Accessing the danger area is made more difficult, but not prevented. For example, in areas which are absolutely shielded from persons and reserved for materials handling only, it is not necessary to equip relevant MTL doors with personal protection.

This is referred to as access obstacle, because movement of people is excluded during regular operation and access to the system is only permissible for instructed operating personnel after the entire system has been switched off, for example for service work and/or inspection services.

In logistics, specialists for material flow distinguish first between applications **without** personnel safety (FTO) and **with** personnel safety (FTM).

EFA-SRT® MTL access prevention with personnel traffic (FTM)

The danger area is prevented from being accessed by means of the door. This variant is used for MTL doors which are operated in connection with present persons, whereby the danger area is to be prevented from being entered or reached into. In these applications, it is mandatory to equip corresponding MTL models with conventional protection systems for the door closing line (e.g. by means of a safety edge and light barrier or door line light grid "TLG") and a drive with gear unit failure protection in order to prevent any hazards to people.

For example, a typical application would be the use of an EFA-SRT® MTL door at the end of a roller conveyor, i.e. at the transfer point from automated materials handling to hand pallet trucks operated by people.



Optimum process connection

Secure and efficient control with different drive modules

The EFA-SRT® MTL door supports all applications in modern intralogistics. Based on the installation situation, the space constraints and the process-related specifications, you will always find the suitable drive. For a long service life and dynamic door travel, frequency converters are used as standard. Operational and personal safety comply exactly with your desired application.

For this purpose, various emergency opening, safety and pulse generator systems can be provided. Moreover, the use of mechanical and/or inductive limit switches (up to CAT. IV) is possible.

Large number of control modules available

A selection of differently powerful control units makes sure that they are always tailored to your individual requirements: For FTM applications in connection with the drive types ASN (1) and KSN (2), you choose between EFA-TRONIC® or EFA-TRONIC® PROFESSIONAL. For FTO applications, the FUZZ-G control unit is only available together with the AKS drive (3) as standard. On request, it can, as well as for the variants KST (4) and KSR (5), be designed as EFA-TRONIC® or EFA-TRONIC® PROFESSIONAL for a supplementary charge. On request, the two latter control units can be equipped with a large number of interfaces dependant upon your needs.

The unique, modular structure of the EFA-SRT® MTL componentary makes the difference: combining modules that are perfectly compatible and can be varied among each other to form the optimum solution for professional material flow, perfect transport and efficient logistics.



Wide range of drive types

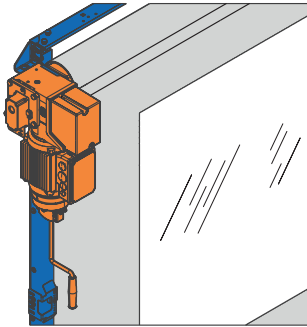

1 Shaft-mounted drive with worm gear WITH GEAR UNIT FAILURE PROTECTION

ASN (FTM, FTO)

Mechanical emergency opening	Via manual override/crank
Performance class/protection type	0.55 kW, 100 Hz, IP54
Position detection	Absolute encoder (no reference run required)
Use as access prevention (movement of people – FTM)	Standard
Use as access obstacle (without movement of people – FTO)	Optional

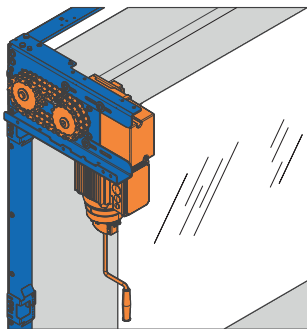

2 Chain drive with worm gear WITH GEAR UNIT FAILURE PROTECTION

KSN (FTM, FTO)

Mechanical emergency opening	Via manual override/crank
Performance class/protection type	0.55 kW, 100 Hz, IP54
Position detection	Absolute encoder (no reference run required)
Use as access prevention (movement of people – FTM)	Optional
Use as access obstacle (without movement of people – FTO)	Optional

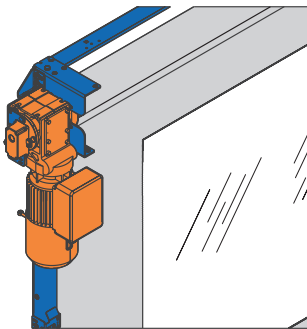

3 Shaft-mounted drive with bevel spur gearbox

AKS (FTO)

Mechanical emergency opening	Without emergency opening function
Performance class/protection type	0.75 kW, 100 Hz, IP54
Position detection	Incremental encoder, optional: absolute encoder (no reference run required)
Use as access obstacle (without movement of people – FTO)	Standard
Use as access prevention (movement of people – FTM)	Not available

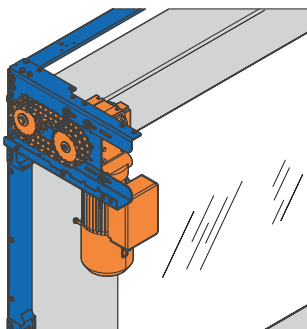

4 Chain drive with bevel spur gearbox

KST (FTO)

Mechanical emergency opening	Without emergency opening function
Performance class/protection type	0.75 kW, 100 Hz, IP54
Position detection	Incremental encoder, optional: absolute encoder (no reference run required)
Use as access obstacle (without movement of people – FTO)	Optional
Use as access prevention (movement of people – FTM)	Not available

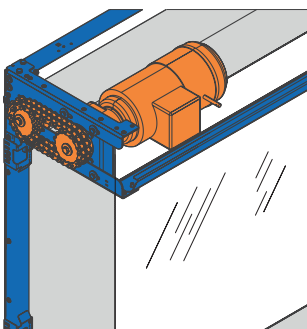

5 Chain drive with spur gearbox

KSR (FTO)

Mechanical emergency opening	Without emergency opening function
Performance class/protection type	1.5 kW, 100 Hz, IP54
Position detection	Absolute encoder (no reference run required)
Use as access obstacle (without movement of people – FTO)	Optional
Use as access prevention (movement of people – FTM)	Not available

Free configurable and individually combinable modules

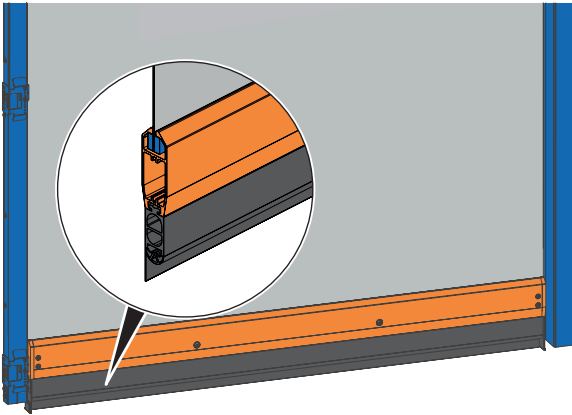

End element, straight

For use as access prevention (movement of people).

For any intended use, a horizontally continuous end profile with a terminal strip in connection with light barrier(s) can be provided as end element of the door leaf. The depth of the frame member structure is thus slightly changed on one side by the additional dimension for the cover of the energy chain for the feed cable of the terminal strip. When an optional door line light curtain (TLG) is selected, the narrow frame member remains unchanged and there is no need for the terminal strip and light barrier.

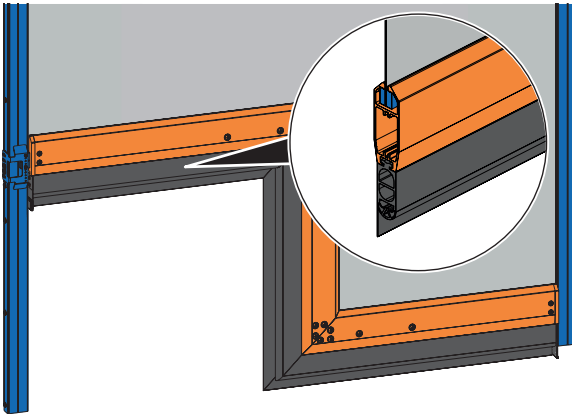

End element with door leaf extension

For use as access prevention (movement of people).

This version is intended for any use. Thanks to the individually configurable, local door leaf extension, optimum adjustment to the conditions on site can be achieved. The door leaf extension is equipped with a horizontal terminal strip at the end profile according to the drawing. Moreover, the door closing level is monitored by light barrier(s).

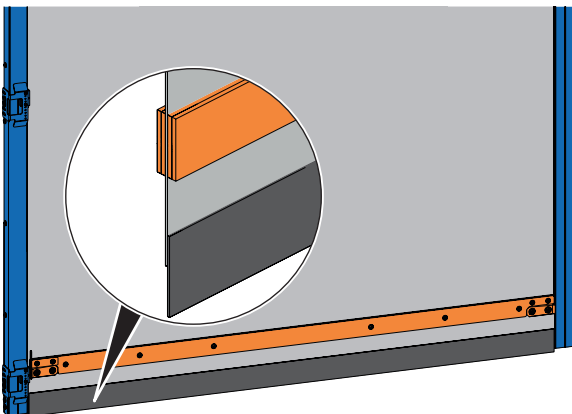

End element, straight

Only for the intended use as access obstacle (without movement of people).

For use as access obstacle, the end element consists of attached metal sheets. When using this element, it is not possible to use a door line light curtain. Optional light barriers can be integrated.

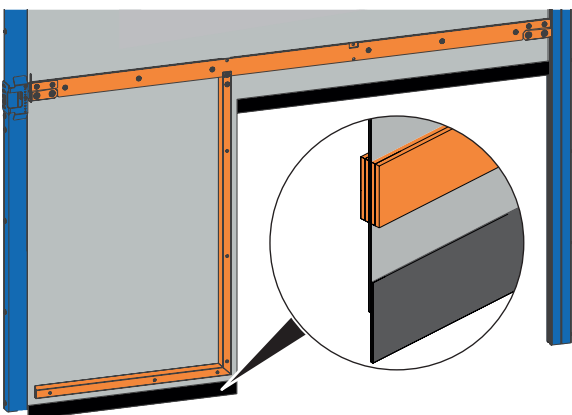

End element with door leaf extension

Only for the intended use as access obstacle (without movement of people).

This version is provided for use as an access obstacle only. Thanks to the individually configurable, local door leaf extension, the best possible adjustment to prevailing conditions can be realised. The door leaf extension is reinforced with aluminium profiles. When using this element it is not possible to use a door line light curtain. Optional light barriers can be integrated.

Technical data:

MTL series

		FTM (with movement of people)	FTO (without movement of people)
Application	Inside door	●	●
	Closing door	–	–
Wind load max.*	According to DIN EN 12424 in classes	–	–
	or in km/h	24	24
Operating forces/secure opening	According to DIN EN 13241	fulfilled	fulfilled
Resistance against penetrating water*	According to DIN EN 13241 in classes	0	0
Air permeability*	According to DIN EN 13241 in classes	0	0
Direct airborne sound insulation R _w *	in dB according to DIN EN 717-1	12	12
Door size (in mm)	Width W max.	3,000	3,000
	Height H max.	3,000	3,000
Maximum door leaf speed*	in m/s	1.8	1.8
Average speed, approx.*	Opening in m/s	1.5	1.5
	Closing in m/s	0.6	0.6
	Closing with EFA-TLG® door light curtain in m/s	1.0	–
Operational temperature	in °C	+ 5 to + 50	+ 5 to + 50
Construction	Aluminium/galvanised sheet steel	●	●
	Stainless steel	–	–
	powder-coated according to RAL	○	○
Door leaf	Door hanging flexible PVC, transparent with warning stripes in different colours	●	●
	flexibles fabric in different colours with/without visible surface	○/○	○/○
Hanging	Material class B2 according to DIN 4102	●	●
	Material class B1 according to DIN 4102 (without visible surface)	○	○
Weight balancing by means of		–	–
Designed for approx. ... load cycles p. a.		250,000	250,000
Life cycle (in years)		12	12
Drive	Three-phase asynchronous motor	●	●
Control unit	EFA-TRONIC®	●	●
	EFA-TRONIC® PROFESSIONAL	○	○
	FUZ2-G	–	○
	Main switch (EFA-TRONIC®/EFA-TRONIC® PROFESSIONAL/FUZ2-G)	●/●/–	●/●/○
	Membrane keypad (EFA-TRONIC®/EFA-TRONIC® PROFESSIONAL/FUZ2-G)	●/●/–	●/●/●
Position detection	Absolute encoder	●	●
	Incremental encoder*	–	–
Voltage supply	L/N/PE 230 V +/-10 % (EFA-TRONIC®/EFA-TRONIC® PROFESSIONAL/FUZ2-G)	●/●/–	●/●/●
	3~L/N/PE 400 V +/-10 % (EFA-TRONIC®/EFA-TRONIC® PROFESSIONAL/FUZ2-G)	○/○/–	○/○/–
	Circuit breaker	16 A (K)	16 A (K)
Emergency opening*	Via manual override/crank	●	○
Safety equipment	EFA-TLG® (door light curtain in door closing level)*	○	–
	Safety terminal strip	●	○
	Light barrier	●	○
	Approach area monitoring	○	○
Safety system including activator	EFA-SCAN® frame member/bollard	–/○	–/○
Door leaf extension	250 mm < B < (B-250 mm)/350 mm < H < 1,200	○	○
Sealing lip extension	10 – 300 mm soft PVC (adjustable)	–	○
	10 – 300 mm made of 2 mm PES fabric (adjustable)	○	–
Frame member extension		○	○

● Standard, ○ Upon request, – Not available, *Depending on door blade, door blade guidance and door size, we reserve the right to make technical alterations.

EFAFLEX
Tor- und Sicherheitssysteme
GmbH & Co. KG
Fliederstraße 14
DE-84079 Bruckberg/Germany
Telephone +49 8765 82-0
www.efaflex.com
info@efaflex.com



Technological advancement. Pioneering design.

EFAFLEX® is a registered and legally protected trademark.

Subject to technical changes. Some diagrams depict special features.

Overall design:

www.creativconcept.de 11121

For more than 40 years, EFAFLEX has developed and designed reliable and highly-efficient high-speed doors. With innovative technology and pioneering solutions for special requests, EFAFLEX continually provides the market with new stimuli. This leadership role through superior technology, the best quality and a maximum degree of security is part of EFAFLEX's identity. More than 1,200 employees guarantee competent consultation and excellent service. Worldwide and always near you.

EFAFLEX 
safe high-speed doors