

### Model # - D610 Remote Food Waste Dewaterer

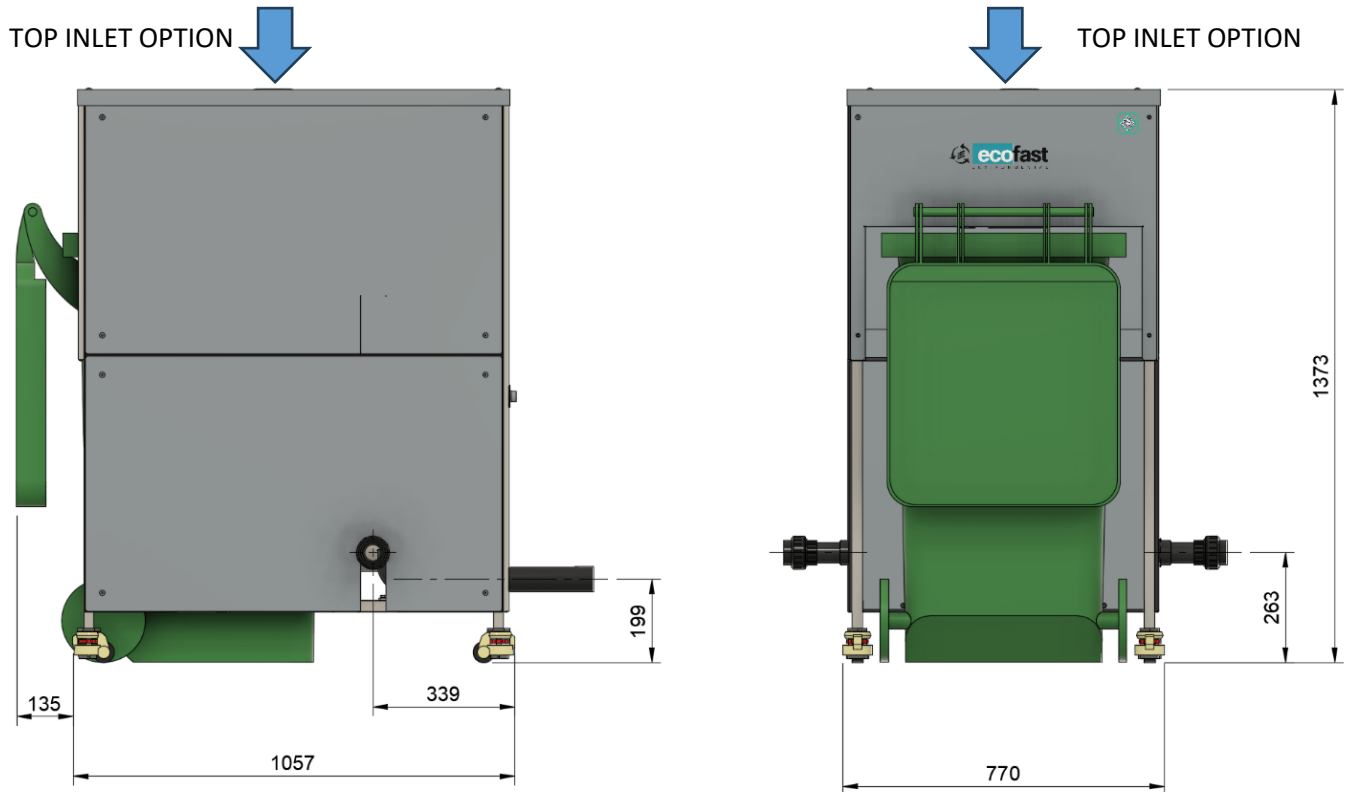

D610 – Food Waste Dewaterer	(DxWxH)
	1086x770x1480
Water connections – 1 x Hot water for cleaning system only	15mm water supply with ¾" threaded standard hose connections
Water Consumption (flow rate) <b>Hot Water</b>	3 litres per cleaning cycle
Water connection height (mm)	792
Waste water inlet connection height (mm)	264
Discharge height (mm)	205
Discharge size (mm & inches)	50 / 2"
Capacity (Food Waste) per minute / hour (kg)	13 / 800
Weight (kg)	128
Decibels (dB)	63-70
Electrical Phase	3
Motor voltage (v)	380-415
Motor frequency (Hz)	50
Motor kilowatt (kW)	1.85
Amps	16
Electrical Connection	Flying leads to be hard wired to site connection
Can be connected to	D390, D450, D700
Bin capacity	240 litre

Version V1.4

