



公司简介

BRIEF INTRODUCTION

森骅机电有限责任公司，专业制造不锈钢雪糕模具，铜镀锡系列雪糕模具，各项指标均符合国家容器卫生标准。

自成立以来一直紧盯国际模具先进技术，拥有先进的CNC加工中心、三坐标测量仪等精密加工检测设备和具有专业知识、经验丰富的模具开发、设计制作人员，熟练运用CAD、UG、PRO/E等软件为用户进行产品分析、设计及模具设计、制作。

本厂愿以优质的产品，合理的价格，高效完善热情的售前售后服务，来迎接五湖四海的宾朋，让我们携手合作，共创未来。

Singhua Co Ltd is a which specialises in producing stainless steel,copper plating sternum moulds for ice cream series,All the norms accord with national hygienic standard for containers.

Since it established,it has always kept pace with the international advanced technology of mould,it possesses advanced CNC processing center,tri-coordinate measuring instrument etc precise processing testing equipment and professional knowledge,there are mold developers,designers and makers with rich experience, who can skillfully execute CAD,UG,PRO/E etc software to analyze,design the products and design,make the moulds.

ICE-CREAM-MOULD

全新引进 国外先进焊接机器人 NEWLY IMPORT ROBOT WELDER

1. 机器人焊接的模具里光外滑;
 2. 机器人焊接稳定, 整体模具美观;
 3. 质量更好, 使用寿命更长。
1. Both inside and outside seems of mould welded by Robot are smooth.
 2. Robot welding is stable to form the whole mould much more beautiful.
 3. Mould quality is better and create longer working life.





ICE-MOULD

多彩生活 从这里开始……

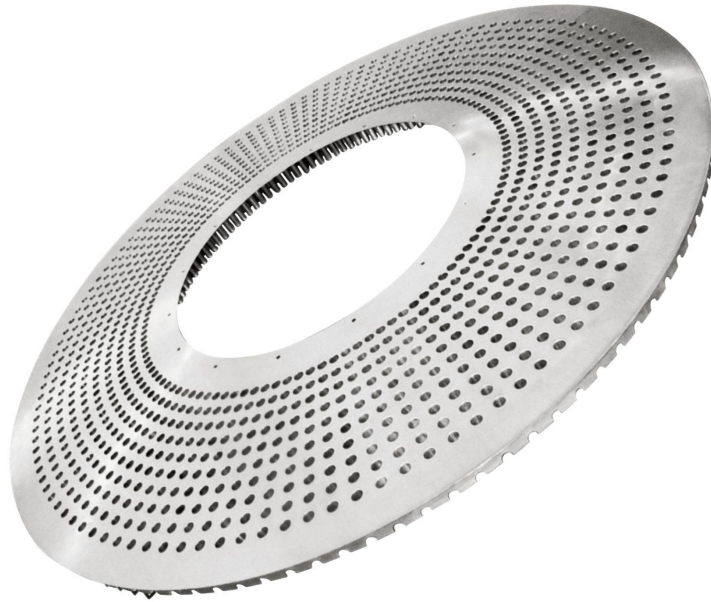

ICE-MOULD

多彩生活 从这里开始……

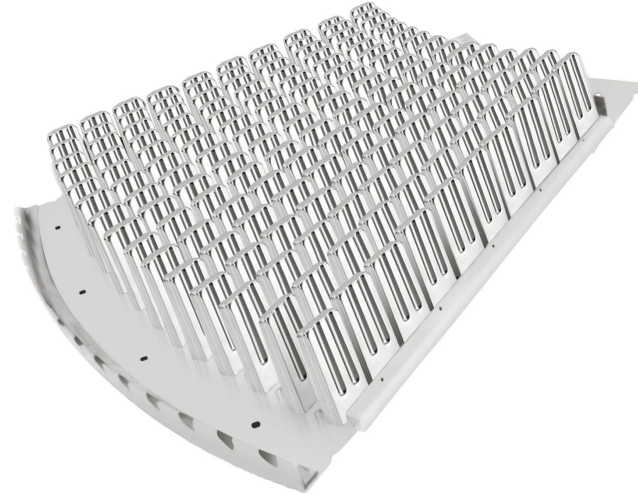

ROLLO

CE Approved JMD8801 type ROLLO mould range available at size of 20, 23, 27, 32, 35 etc, to meet customer's requirements, and we offer production according to customer's request. Material options: stainless steel 316L, 904, 254. Most common is stainless steel 254.

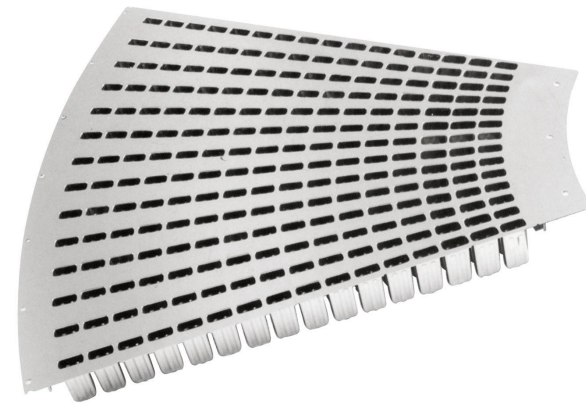
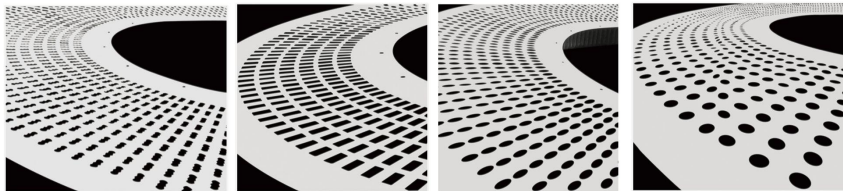

6支花色线条模

Mould strip with 6 cavities

杯体/Cavity Thickness	0.6mm
面板/Panel Thickness	2.0mm
材质/Material	304/316L 不锈钢 (SS)
备注/Remark	可根据客户要求制作
	Produce according to customer's request



12支花色线条模

Mould strip with 12 cavities

杯体/Cavity Thickness	0.6mm
面板/Panel Thickness	2.0-2.5mm
材质/Material	304/316L 不锈钢 (SS)
备注/Remark	可根据客户要求制作
	Produce according to customer's request



18支花色线条模

Mould strip with 18 cavities

杯体/Cavity Thickness	1.0mm
面板/Panel Thickness	3.0mm
材质/Material	304/316L 不锈钢 (SS)
备注/Remark	整体拉伸成型, 为中亚客户制作
	Formed by drawing die, specially for customer from middle asia



18支花色线条模

Mould strip with 18 cavities

杯体/Cavity Thickness	0.6mm
面板/Panel Thickness	2.5mm
材质/Material	304/316L 不锈钢 (SS)
备注/Remark	可根据客户要求制作
	Produce according to customer's request



18支花色线条模

Mould strip with 18 cavities

杯体/Cavity Thickness	0.8mm
面板/Panel Thickness	2.5mm
材质/Material	304/316L 不锈钢 (SS)
备注/Remark	机器人焊接/Robot weld



14支花色线条模
Mould strip with 14 cavities

杯体/Cavity Thickness	0.8mm
面板/Panel Thickness	2.5mm
材质/Material	304/316L 不锈钢 (SS)
备注/Remark	可根据客户要求制作
Produce according to customer's request	



24支花色线条模
Mould strip with 24 cavities

杯体/Cavity Thickness	0.8mm
面板/Panel Thickness	2.5mm
材质/Material	304/316L 不锈钢 (SS)
备注/Remark	可根据客户要求制作
Produce according to customer's request	



36支花色线条模
Mould strip with 36 cavities

杯体/Cavity Thickness	0.8mm
面板/Panel Thickness	2.5mm
材质/Material	304/316L 不锈钢 (SS)
备注/Remark	可根据客户要求制作
Produce according to customer's request	



40支盐水槽雪糕模具
Mould tray with 40 cavities

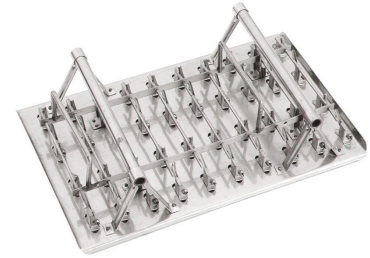

杯体/Cavity Thickness	0.8mm
面板/Panel Thickness	2.0mm
材质/Material	304/316L 不锈钢 (SS)
备注/Remark	保护架均用不锈钢制作
The protection frame are all made of stainless steel	



新型冻结槽冰淇淋模具
New Type Tray mould

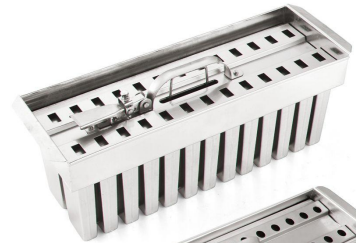

杯体/Cavity Thickness	0.8mm
面板/Panel Thickness	2.0mm
材质/Material	304/316L 不锈钢 (SS)
备注/Remark	可根据客户要求制作
Produce according to customer's request	

OTHER MOULD SHOW

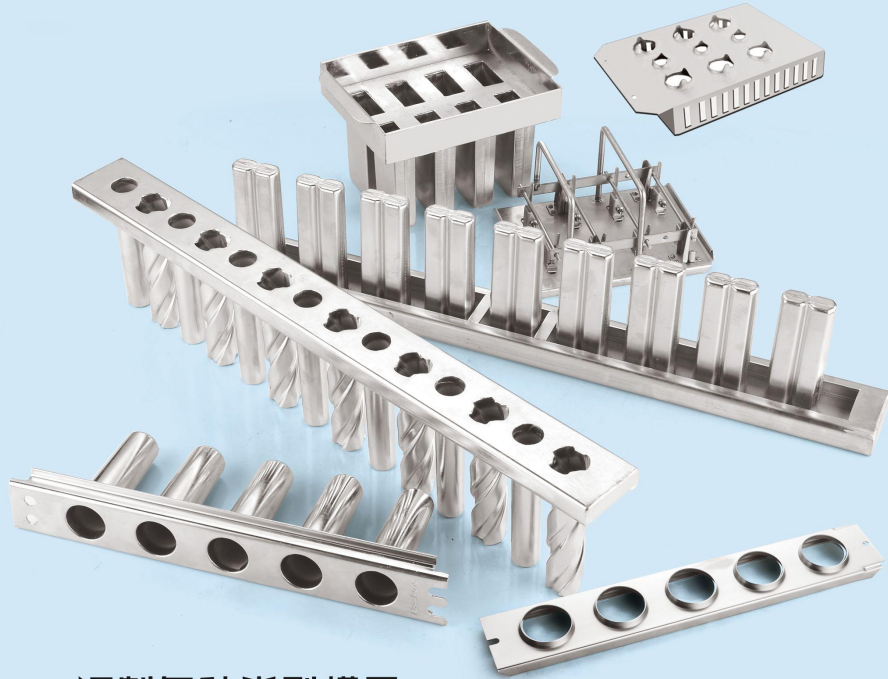

订制各种类型模具

All material, thickness, shape and size of mould could be according to customer's requirements.

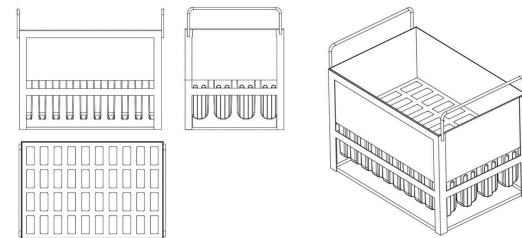
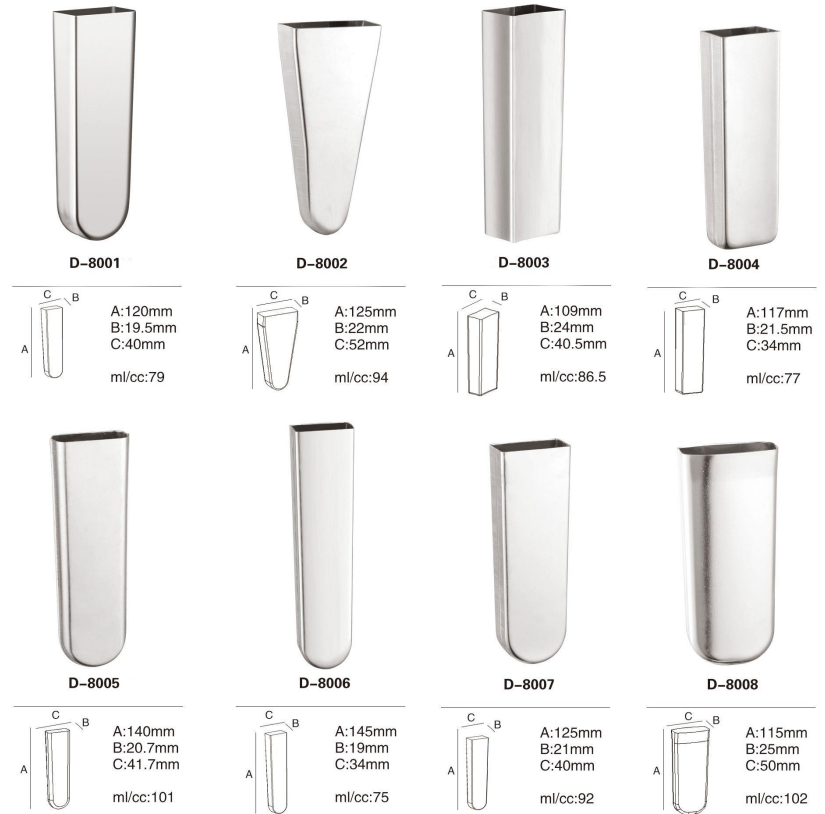

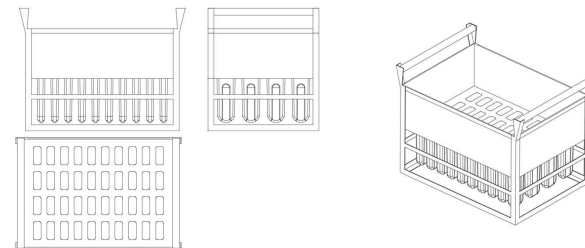
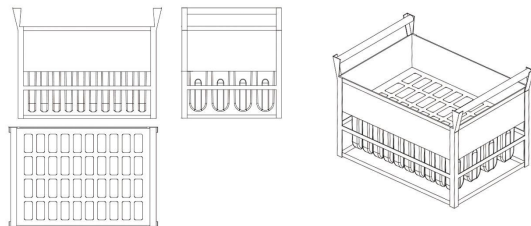
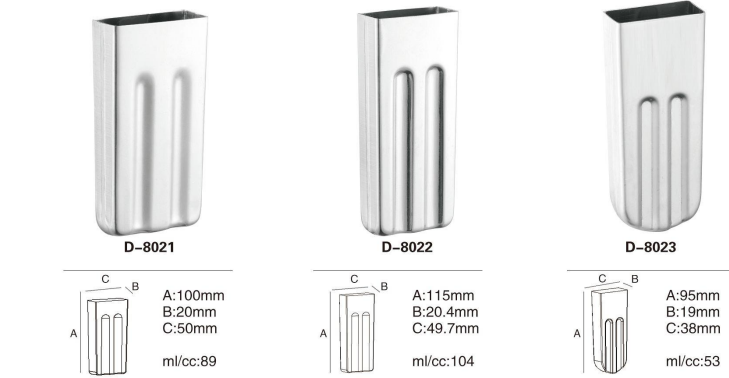
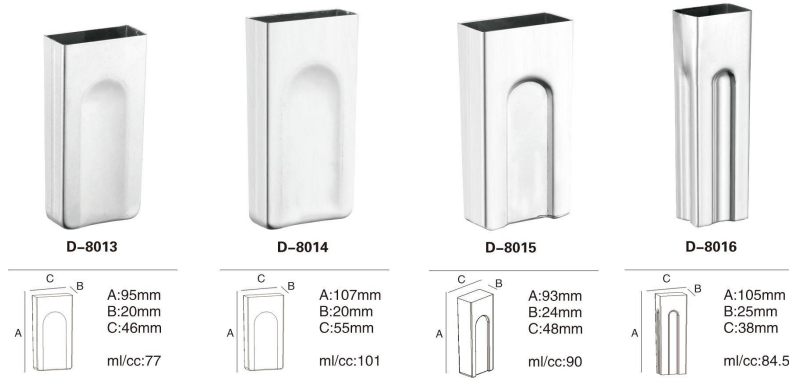
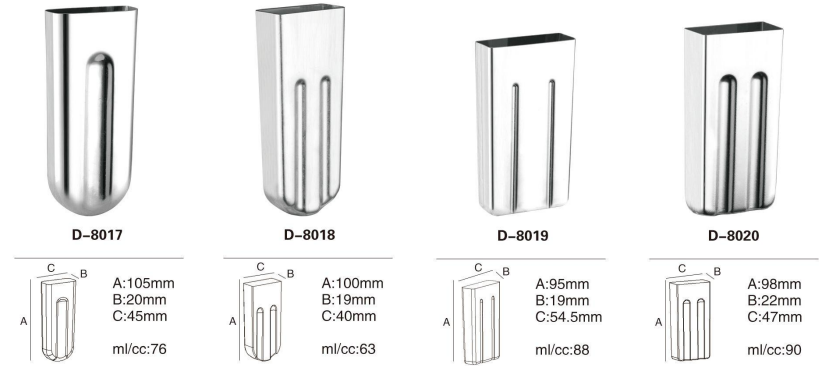
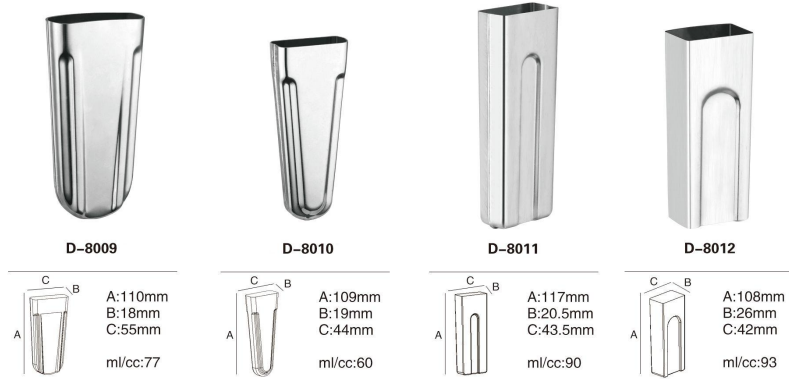

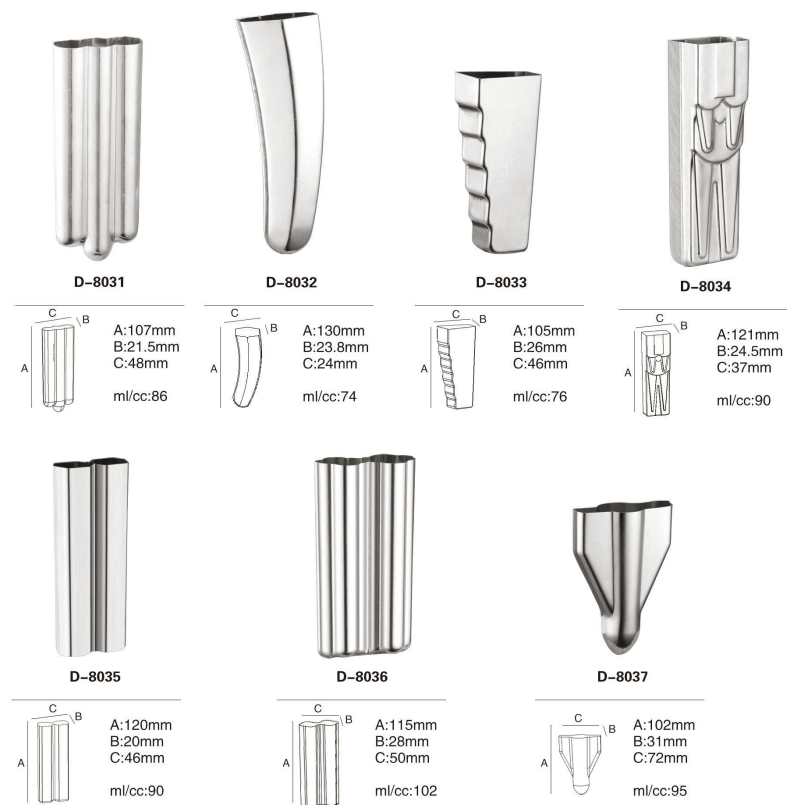

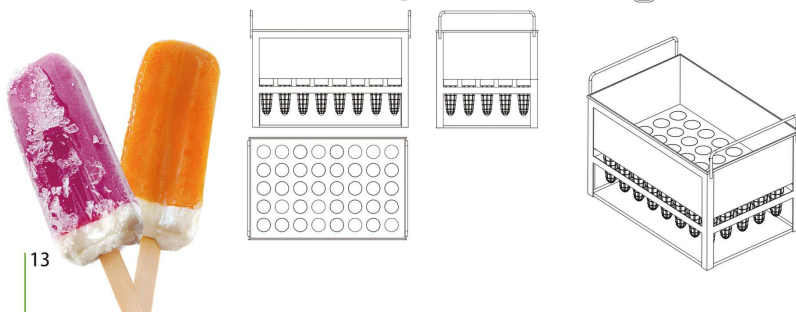
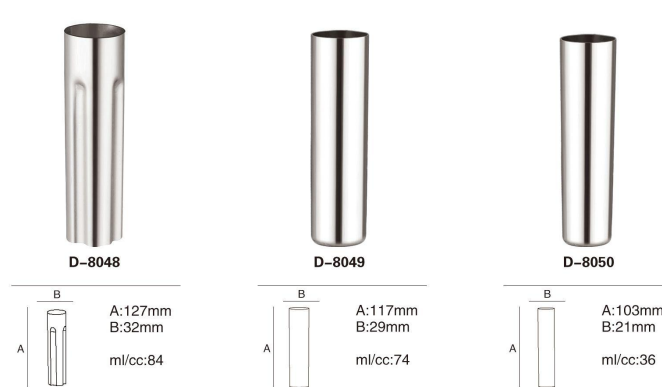
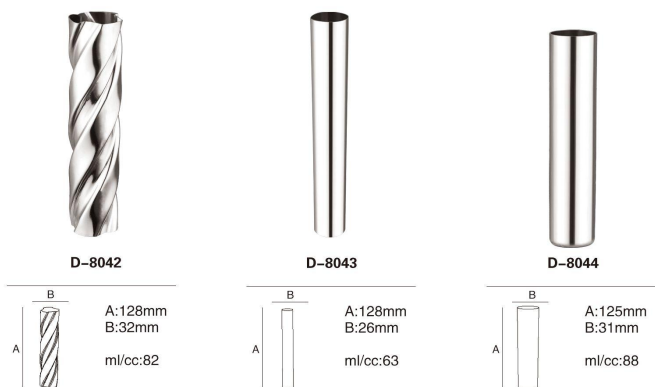
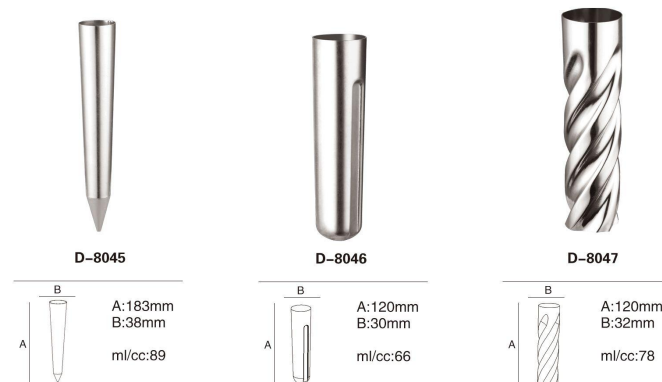
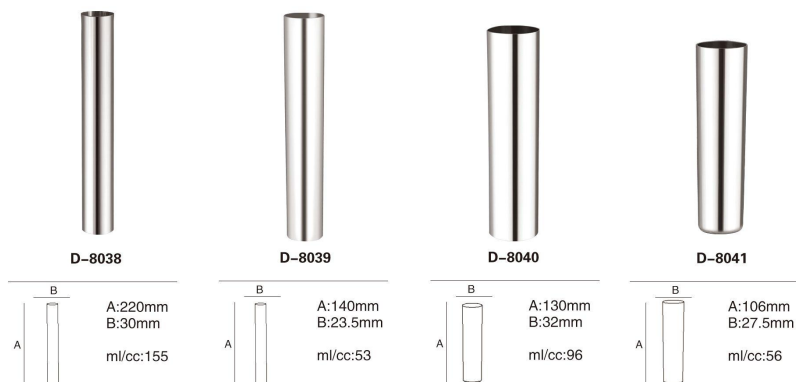



D-8051

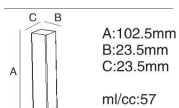

D-8052

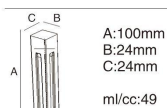

D-8053

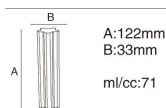

D-8057

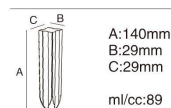

D-8058

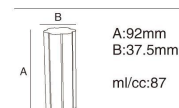

D-8059

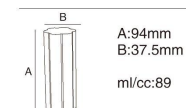

D-8054

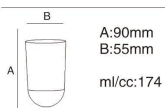

D-8055

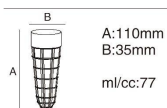

D-8056

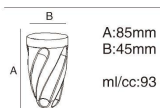

D-8060

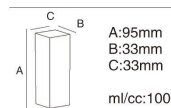

D-8061

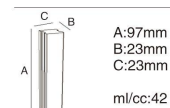

D-8062

Top Caliber: Φ 35mm
Capacity: 20ml



BAIANINHO

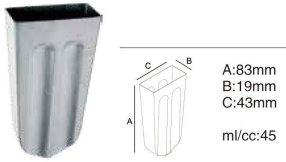

BEIDA

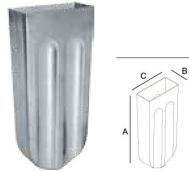

MEGAMID

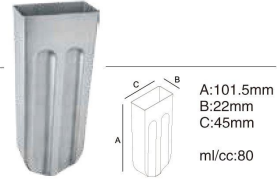

MEGAMEX



RECHEIO

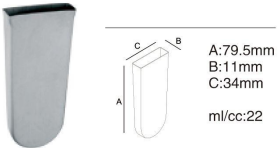

BRILIS

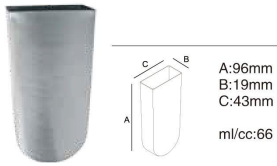

SKIMO

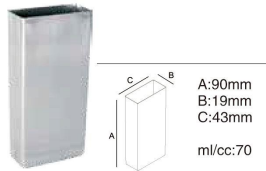

WAVE

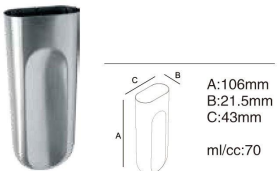

LÁPIS

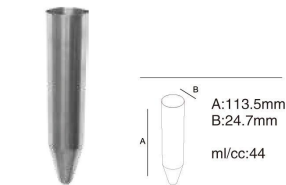

RECIFE

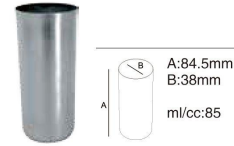

LOLLITA

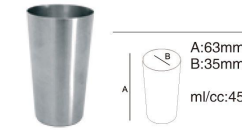

LOLLY

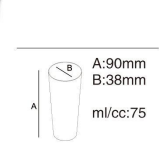

ITUZINHO



DRILL



TETRA

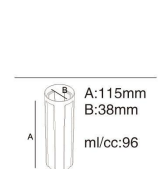

HEXAGONAL



CATARINA HELICOIDAL



CATARINA LISA

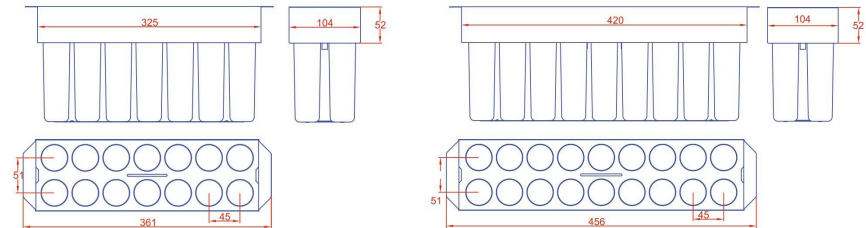
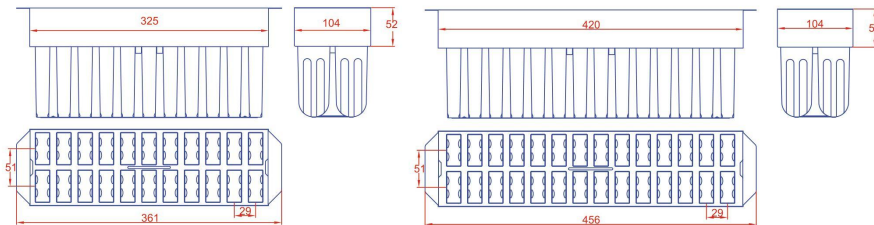
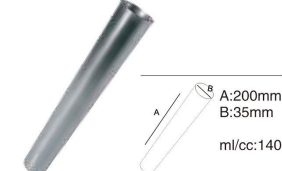

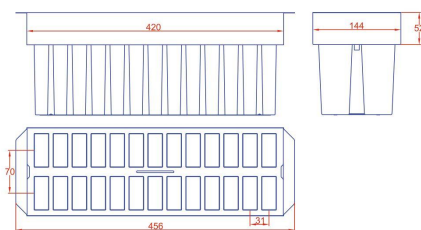

模具保养知识 Mould Maintenance Knowledge

- Choose calcium chloride suppliers with good reputation, which guarantees the quality of calcium chloride that is less corrosive and contains less harmful impurity elements.
选择正规厂家的氯化钙。优质的氯化钙对模具腐蚀性较小，含有害杂质也较少。
- Having received the mould, steam it or clean it by cleanser.
收到模具后，蒸汽清洗或清洁剂清洗干净。
- Check PH Value regularly, the standard PH value of the brine should be between 8 and 9, which is slightly alkaline. When the PH value is below 8, the water is too acid to immerse the mould in.
定期检查PH值（酸碱度），标准配置盐水PH值应处于8-9之间，呈轻微碱性，当PH值低于8时，酸性太浓，模具不宜与盐水接触。
- Adjust the PH value of the calcium chloride solution because the brine might turn out to be acid in 2 or 3 days; when PH value is below 8, please add sodium hydroxide (also called caustic soda) into the brine; when PH value is higher than 9, add acetic acid.
定期调整氯化钙溶液的PH值，盐水在使用2-3天后就会呈酸性，当PH值低于8时，请在盐水中加入氢氧化钠（俗称烧碱）；当PH高于9时，加入乙酸调整。
- It is prohibited to expose the mould outdoors or in the icehouse.
不能存放在冷库，野外等地。
- Ensure the mould is only used when the brine is appropriate.
等氯化钙等溶液调好后，才能把模具放下使用。
- The mould should be discharged, cleaned manually, and dried after use.
使用完后应卸下，人工除垢，清洗干净，凉干收藏。
- Please pay extra attention here! In the course of production, please manually pull out the semi-finished ice cream if ice cream failed to demould completely, otherwise the secondary freeze can deform the mould.
若生产过程中，模具中有未脱模的雪糕，必须手工将雪糕半成品拔出，以免二次冻结使模具变形。请特别注意此种情况！



Singhua Industry Co Ltd

ADD: No.138 Qianjin Rd, Zhiying, Yongkang, Jinhua, Zhejiang, China, 321300
TEL: +86 185 9188 6592
+86 029 3333 8391
FAX: +86 029 3333 8391

www.icelollymold.com

Sing Hua

ICE-MOULD

多彩生活 从这里开始.....



森骅机电有限责任公司
Singhua Industry Co Ltd