

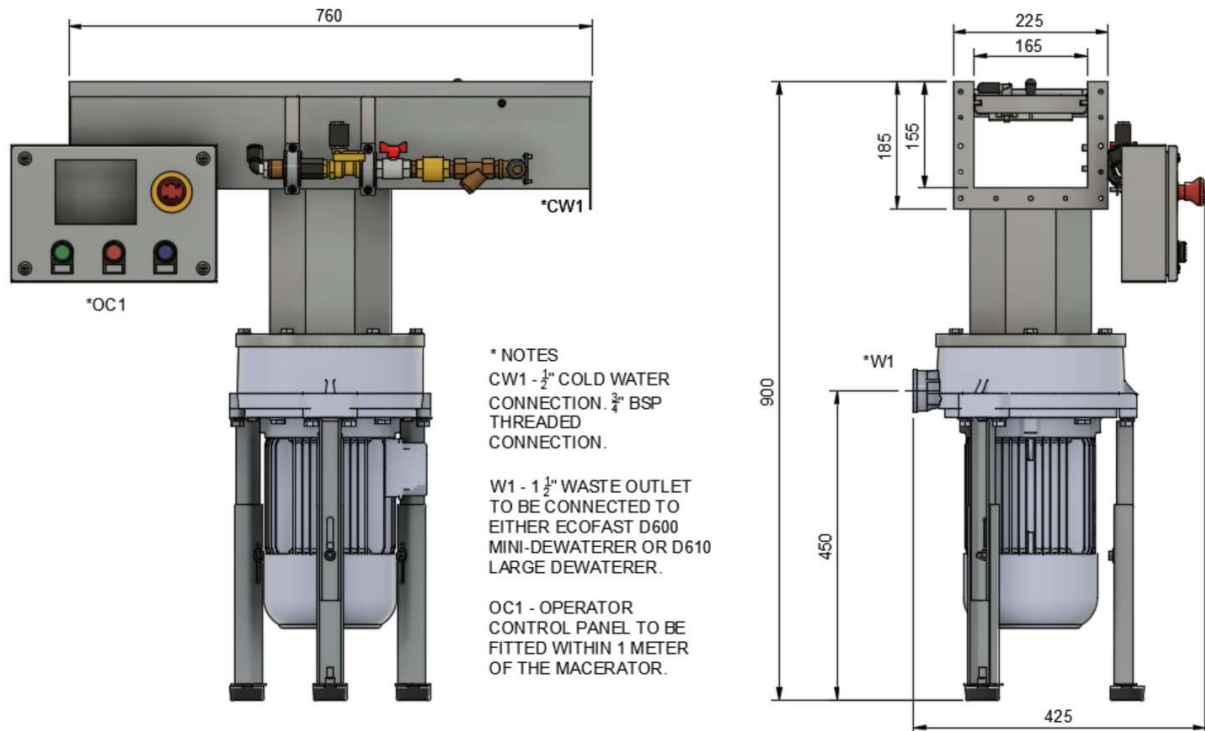

Model # - D392 Double Trough Macerator



D390 – Remote Dewaterer - Mark III Food Waste Dehydra	(DxWxH)
	760x425x900
Water connections – 1 x Cold water	15mm with 3/4 standard hose connections with 3 bar pressure
Water Consumption (flow rate) Cold Water Water flow dependant on the location of the dewatering unit.	10-15 litres per minute
Air-break not supplied as standard	n/a
Water connection height (mm)	772 APPROX
Discharge height (mm)	450
Discharge size (mm & inches)	40 / 1 1/2"
Capacity (Food Waste) per hour (kg)	800
Weight (kg)	70
Decibels (dB) – dependant on food processed	72-84
Electrical Phase	3
Motor voltage (v)	380-415
Motor frequency (Hz)	50
Motor kilowatt (kW)	2.2
Amps	16
Options	Cutlery saver
Electrical Connection	Power cables to be connected to the Ecofast control system
To be connected to either	D600, D610, T400

