

AAD TECH GROUP

COMPANY PROFILE

Our group companies are a new age combination of technologies , latest methodologies with traditional values having an group experience of almost 75 Years !!

www.aadtech.in



ABOUT THE COMPANIES





COMPANY **AADTECH**

Completely dedicated to energy conservation in the space of Air handling Units and ventilation . AAD TECH aims to design build and operate Air handling unit with least power consumption . We are a total solution provider and our major strength are our hundreds of satisfied customers. This is a 15yo company having an average turn over of 35-40 Cr .

www.aadtech.in





COMPANY

AIRPAC CLEANTECH

Airpac is a 30 year old company renamed to Airpac Cleantech in 2015 . It specializes in design and execution of any and every pharma air bearing equipment's , Offering cleanroom design & installation services coupled with cleaning and air cleaning equipment with the latest in world standards. Airpac has a dedicated service team which takes care of clean room validations and equipment maintenance as well . The yearly turn over for Airpac is close to 14-17 Cr on an average

www.aadtech.in





COMPANY MELFRANK

Established in 1991 Melfrank is well experience in design and execution of new cooling towers of as high as 3000 M³/Hour capacity . It has vast experience in conversion of timber to pultruded towers to increase the life span of the towers and has taken up maintenance activity of many such towers. Melfrank also possesses unique capacity to retrofit the old cooling tower fan wit the new EC type axial fan to reduce fan power consumption by 35-45% . The average turn over of the company is around 14-15 Cr.

www.aadtech.in



PRODUCT CLOUD

Cloud Analytics

Close looping of processes.

Air Handling Unit Retrofits with EC fans

Design and install Smart AHU with best SFP

Design and implement low L/G ratio Cooling Tower

Various Pharma Air movement equipment
Laminar flow , fan filter modules , pass box etc .

Cooling tower Retrofit with EC fans

Cooling tower maintenance and AMCs.



BUSINESS SECTORS WE CATER TO



PHARMA



IT COMFORT &
HOTELS



AUTOMOBILES



BANKING



FMCG



AIRPORT



TELECOM



HOSPITAL



AGRICULTURE



RETROFIT OF OUR SYSTEMS BROWN FIELD PROJECTS

- Savings up to 70% achieved with Smart AHU change over
- Savings up to 70% achieved with Air Washing Unit change over
- Savings up to 34-40 % achieved with AAD TECH EC Fan Retrofit in Cooling Towers
- Savings upto 34-40 % achieved with AAD TECH AXIAL EC Fan Retrofit.
- Savings up to 34-40 % achieved with AAD TECH EC Fan Retrofit in Paint Booth and Plant Ventilation.



www.aadtech.in



OUR STANDOUT EQUIPMENT



BIO SAFETY CABINET

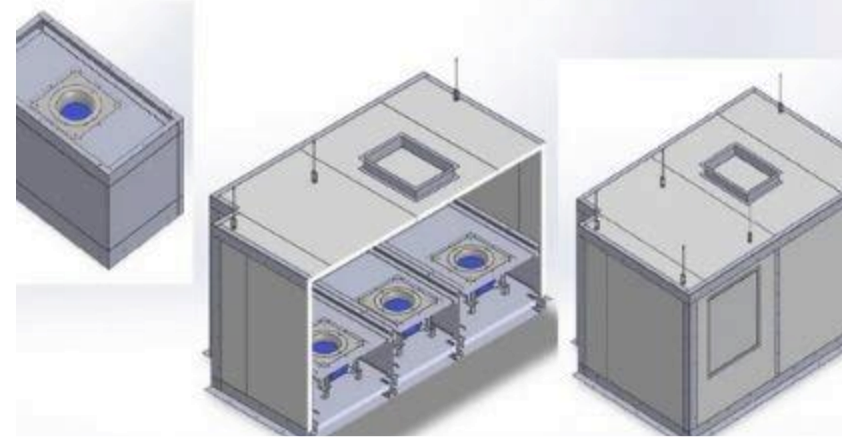

FFM LAFs

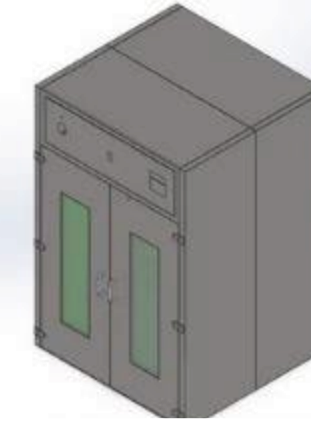

DYNAMIC PASS BOX

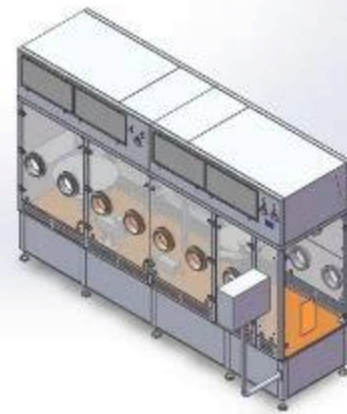

RABS

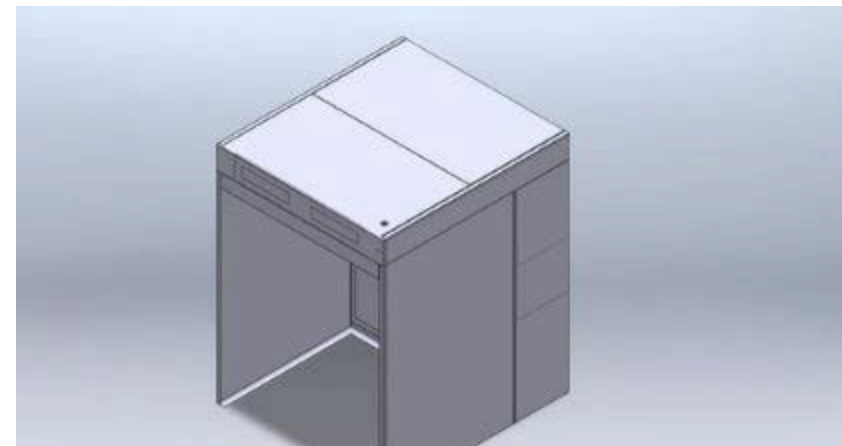

REVERSE FLOW LAMINAIR FLOW

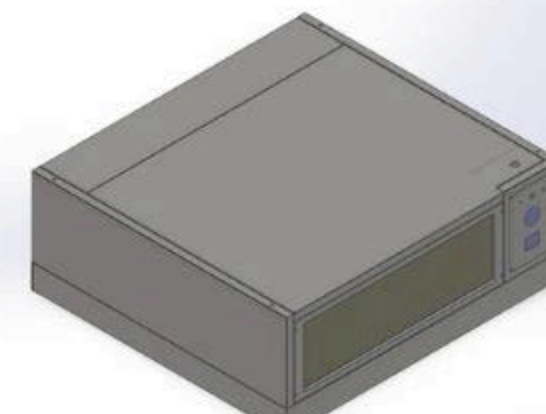

VERTICAL LAMINAIR FLOW

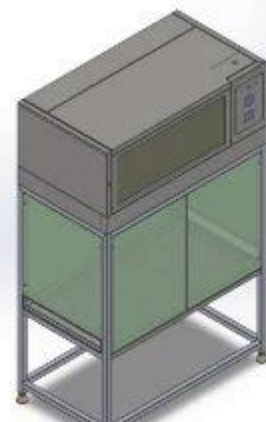

MOBILE LAMINAIR FLOW

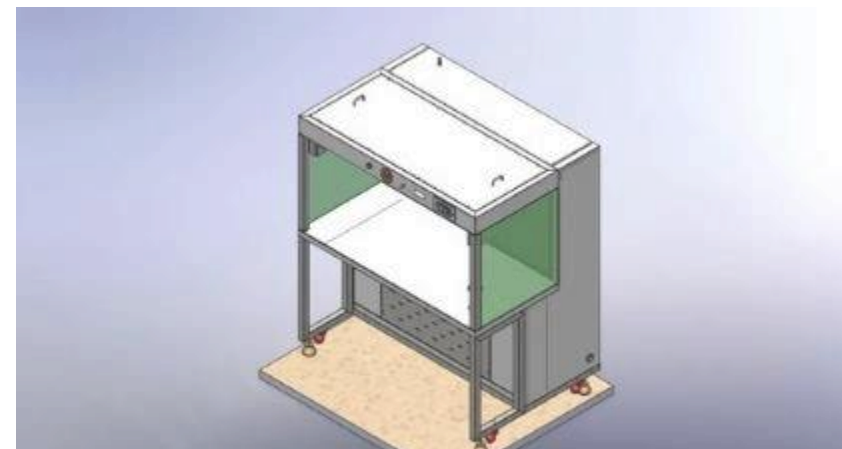

HORIZONTAL LAMINAIR FLOW

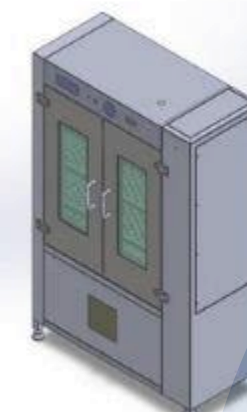

GARMENT STORAGE



SFP BASED SMART AIR HANDLING UNITS

COMPANY



IOT ENABLED AHU!

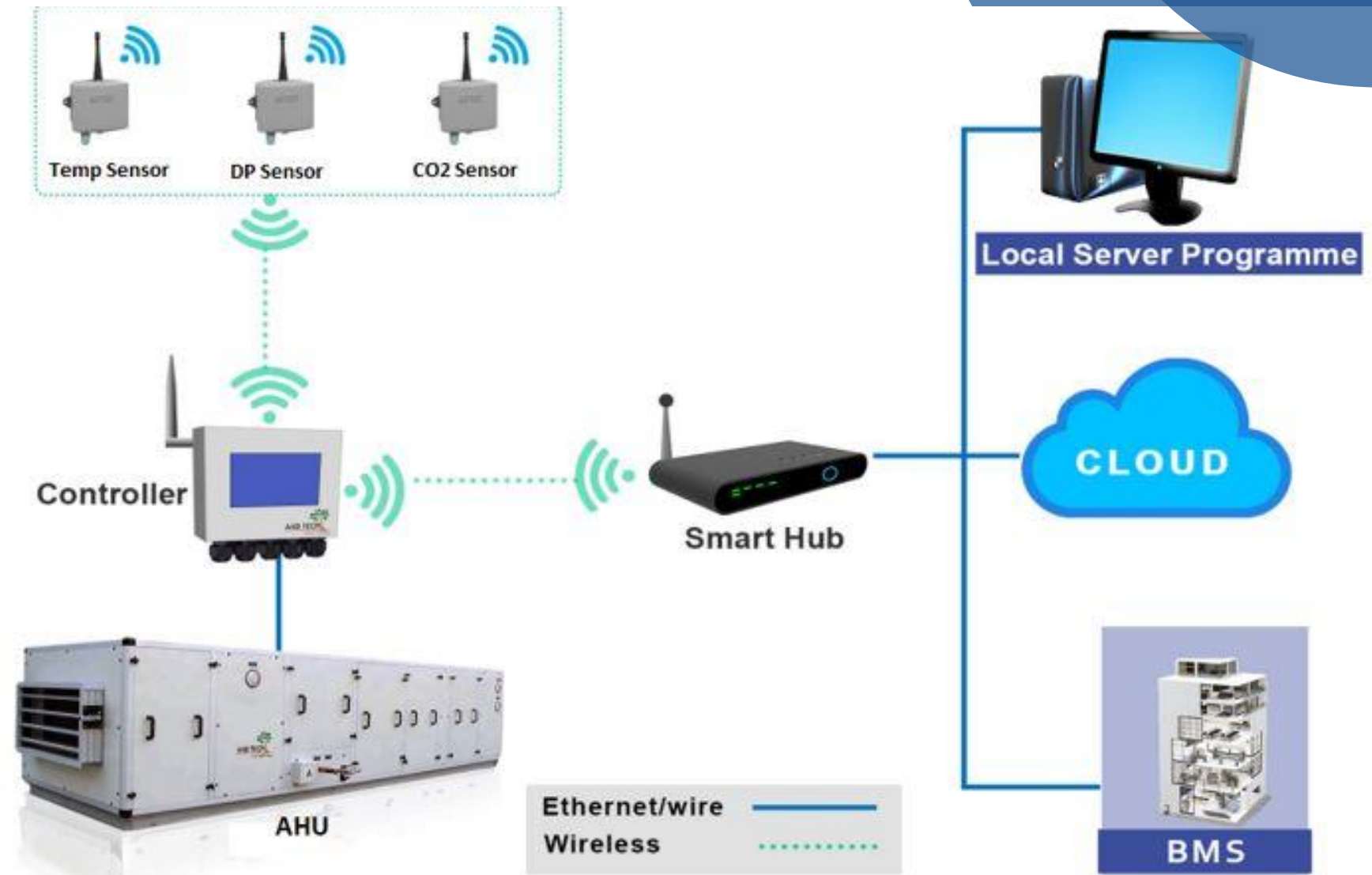

Get anything and everything from AHU to your desktop !!!

www.aadtech.in



FEATURES OF AIR SIDE EQUIPMENT'S SMART FEATURES

- Custom design of AHU/AWU/VU/ASU based on best energy rating
- Cooling coil design and selection
- Hot water coil design and Electrical Heater selection
- Smart programmable touch HMI controller
- BMS compatible
- Inbuilt high efficiency EC blowers with IE-5 motors
- High-efficiency energy-saving filters
- Optional IOT cloud control and configure settings.
- Smart component monitoring system.



FEATURES OF AIR SIDE EQUIPMENT'S DIRECT BENEFITS

- Energy savings up to 70%
- Large air volume deliverable capacity
- Compact in size
- Less heat dissipation from motor
- Ultra-low noise level
- Installation as per ISO standard
- Optional IOT cloud control and configure settings.
- Low maintenance required

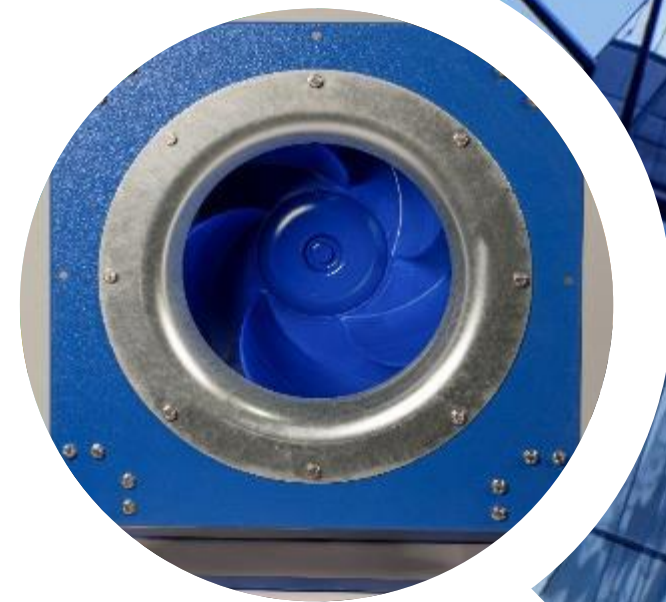

OUR CLIENT PRESENCE INDIA

ANDHRA PRADESH

BIHAR

DAMAN & DIU

DELHI

GOA

GUJARAT

HARYANA

HIMACHAL PRADESH

KARNATAKA

MADHYA PRADESH

MAHARASHTRA

ORISSA

PUNJAB

RAJASTHAN

TAMIL NADU

TELANGANA

UTTAR PRADESH

UTTARAKHAND

WEST BENGAL

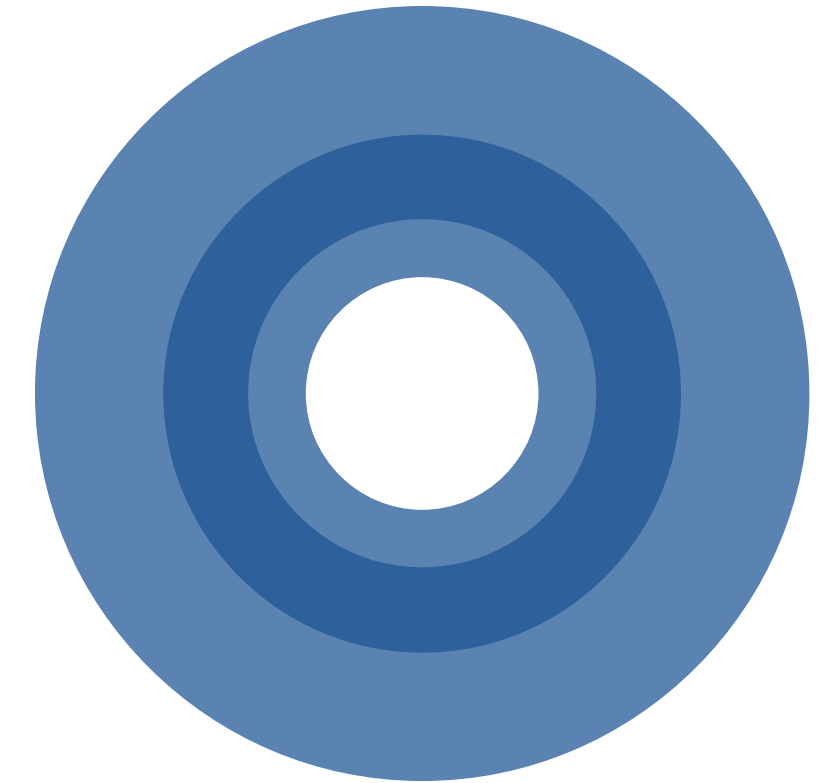

www.aadtech.in



OUR CLIENT PRESENCE GLOBALLY

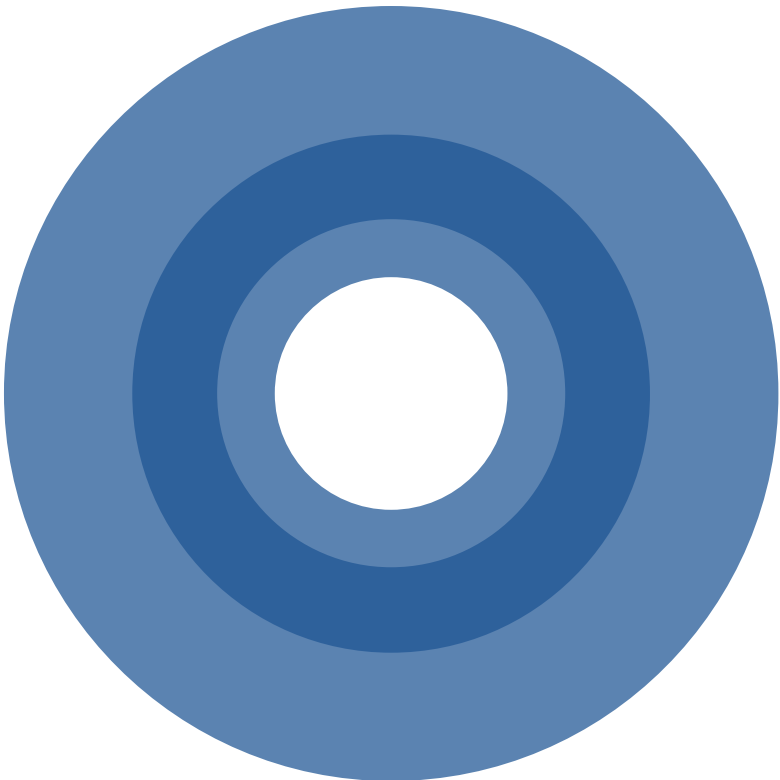
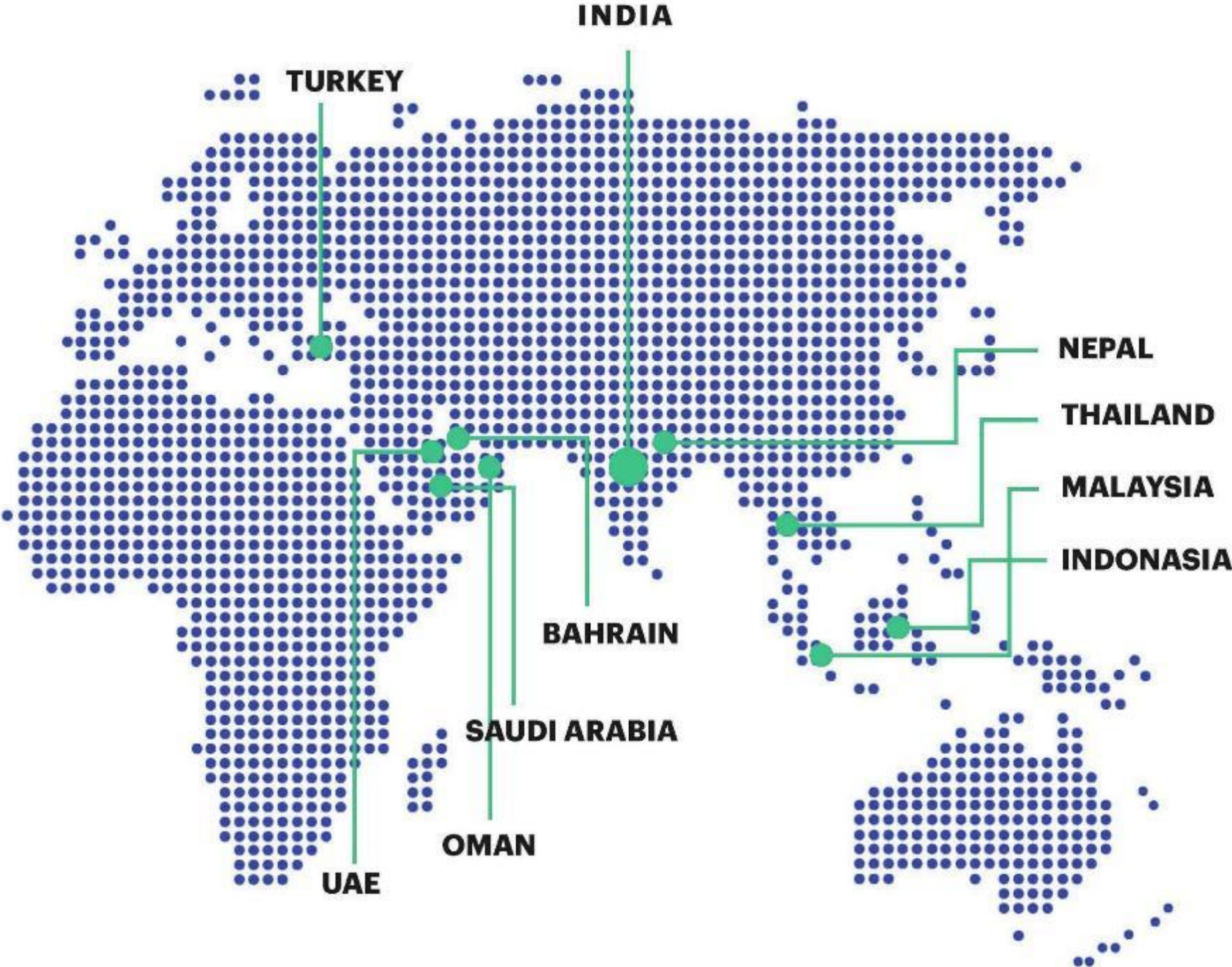

www.aadtech.in



**COMPANY
RESIDENT
OFFICE
AND
SERVICE
SUPPORT.**



www.aadtech.in



CONTACT US

Walk with us through the journey of innovation and technology immensely influenced towards building products for a better sustainable tomorrow.

”

 +91 95946-27773

 www.aadtech.in

 sales@aadtech.in

 21, Papa Industrial Estate, 40
Suren Road, Andheri (E),
Mumbai 400093.





AADTECH
CONSERVE ENERGY

THANK YOU

www.aadtech.in