

aw

Design School

layout

**A Practical Guide
for Students and Designers**

Richard Poulin

out

Design School layout

A Practical Guide for Students and Designers

Richard Poulin



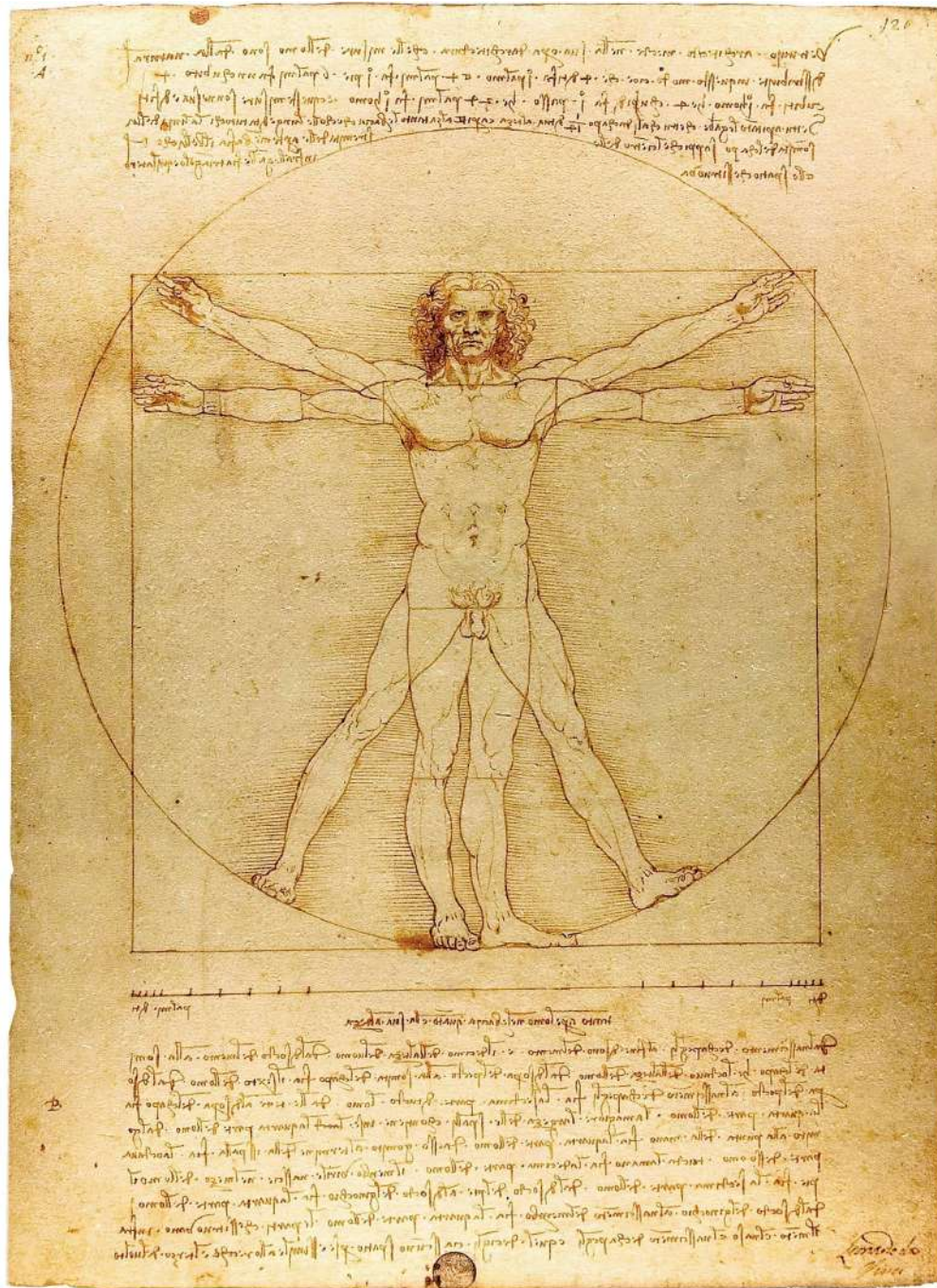

Vitruvian Man

1487

Leonardo da Vinci
(Italian, 1452–1519)

Table of Contents

Introduction

1 **Layout Fundamentals**

Absolute and Relative Measurements

Proportional Systems

Golden Section

Fibonacci Sequence

Dynamic Rectangles

Related Systems

Van de Graaf Canon

Villard Diagram

Preferred Numbers

Renard Numbers

Special Numbers

The Rule of Thirds

Le Modulor

ISO Standard Paper Sizes

Standard Book Sizes

Test your Knowledge

2 **Anatomy of a Grid**

Margins

Columns

Modules

Spatial Zones

Flowlines

Markers

Gutters and Alleys

Fields
Terminology
Test your Knowledge

3 Grid Systems

The Modern Grid System
Manuscript
Symmetrical (Single-, Double-, and Multiple-Column)
Modular
Asymmetrical (Columnar, Modular)
Baseline
Hierarchical
Marber
Compound
Test your Knowledge

4 Compositional Principles

Balance
Movement
Symmetry
Asymmetry
Tension
Contrast
Figure-Ground
Test your Knowledge

5 Layout Characteristics

Pacing and Sequencing
Pattern and Form
Rhythm and Flow

Space
Alignment
Emphasis, Hierarchy, and Scale
Test your Knowledge

6. Layout in Practice

Test your Knowledge Answers

Bibliography

Index

Credits

Introduction

*“Perfection is achieved not when there is nothing more to add,
but when there is nothing left to take away.”*

—Antoine de Saint-Exupery

Layout is one of the most powerful forms of visual expression and communications. It is the descriptive term used for the organization and placement of type, image, color, and other relevant design elements within a composition. It is the method by which a graphic designer arranges, places, and composes these visual elements which ultimately affects the understanding of, and reaction to, this information by the reader. When a compositional layout reflects a visual treatment that enhances both its narrative and visual meaning, it can convey a memorable and timeless message that will always be associated with a specific human emotion.

The goal of any graphic designer is not just to organize information on a printed or digital page, but also to understand it and compose it in a manner that facilitates and enhances understanding by the reader or user. The methods used to create compositional layouts, as well as the design fundamentals of measurement, grid anatomy and systems, compositional principles, and layout characteristics, are critical considerations for a graphic designer.

Compositional layout, of course, is all around us. Since the beginning of mankind, we have had a need to record and organize our stories for everyone to witness and experience. After we learned to “speak” verbally, we then spoke “visually” by leaving crude marks on walls and surfaces. From Sumerian cuneiform inscribed on clay tablets and Egyptian hieroglyphics painted on the walls of funereal tombs to carved Roman inscriptions on triumphal arches and Renaissance illuminated manuscripts, composing and ultimately sharing those experiences with one another has been a common feature of human interaction throughout history.

As our world has become more diverse and complex, so has the means by which we communicate our stories to one another in their many forms and media. For centuries, the fundamental design principle of layout has been an essential visual communicator that has always reflected civilization, culture, technology, and the human condition at any given time period. Its evolution has been shaped by the developments of human communication needs, from the

rudimentary hand and early print technologies to mechanical printing and the invention of desktop publishing and digital media. Many of the proportional systems, page sizes, book sizes, grid systems, and compositional principles explained in this volume and used today within the graphic design profession have existed for centuries.

Layout in practice is the process of composing letters, words, and text for almost any context imaginable, and it is among the most important design principles you need to master for creating effective and meaningful graphic design. Graphic designers learn the nuances of layout in order to use it creatively, with imagination and a sense of exploration, while maintaining respect for its rules and traditions.

Design School: Layout is a back-to-basics, practical guide to the rules and practices of compositional layout. The foundation for any successful graphic designer is an understanding of the fundamentals of layout, a crucial skill which underpins almost every other aspect of graphic design. This book provides an in-depth account of the basic elements and principles of compositional layout—explaining what they are, why they are important, and how they can be used in an effective manner.

Graphic design provides a means for you to “express” your own imagination in ways that do not rely solely upon spoken or written language. Every element used in graphic design, such as compositional layout, has the potential to communicate something specific. Although the explanation and ultimate use of design elements and principles may seem cut-and-dried, the quality of these elements and principles is perceived solely through the expression of the total message by a graphic designer.

Design School: Layout not only explores a graphic design student’s experience; it includes work by some of the most successful and renowned design practitioners from around the world and demonstrates how they have applied these basic principles to their work. By examining both student and professional work, *Design School: Layout* is also a more meaningful, memorable, and inspiring guide for graphic design students, as well as for novice practitioners starting their professional careers.



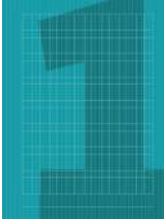

Section 1

Layout Fundamentals

The foundation for any successful graphic designer is an understanding of the fundamentals of compositional layout. Throughout a graphic designer's education and career, the basic tenets of compositional layout are constantly referred to for inspiration, ideas, and as reminders of how they provide the basis for designing memorable and communicative work.

Layout fundamentals, such as measurement and proportion, are the framework for creating clear and meaningful graphic design in the most appropriate and effective manner. These basic tenets and principles provide structure and further enhance meaning in your work. Without a reliance on these fundamentals, your compositional layouts will be ineffective, non-communicative, and will not “speak” to any audience.

Absolute and Relative Measurement Systems

Measurement is defined as “the assignment of a number to a characteristic of an object or event, which can be compared with other objects or events.” Since the early eighteenth century, measurement has been based on universal systems and standards that are solely dependent upon its context and discipline.

Measurement systems are an integral part of layout, from the spatial dimensions of a page grid, to the organization and spacing of its visual elements. Understanding various absolute and relative measurement systems will enhance and broaden your knowledge of compositional layout.

In graphic design, graphic designers primarily rely upon two measurement systems for the majority of their work; one is based on measurements of fixed or absolute values and the other is based on a series of rational or relative values.

Absolute Measurement Systems

An absolute measurement system, such as the American–British Point System and the Metric System, is always based on a standard, fixed value of units—picas and points, and millimeters and centimeters respectively. The following absolute measurement systems are always communicated in finite terms and never change:

Point

The American–British Point System, developed by printer Nelson C. Hawks (American, 1840–1929) in the 1870s, is based on standard fixed values of the units point and pica which measure 0.01383 and 0.166 inches, respectively. There are twelve (12) points in one pica and six (6) picas, or seventy-two (72) points, in one inch. This standardized measuring system’s base element—the point—was originally named for noted type designer François-Ambroise Didot (French, 1730–1804) in 1783, who improved the system that was originally invented by Pierre Simon Fournier (French, 1712–1768).

ABSOLUTE MEASUREMENT: POINT

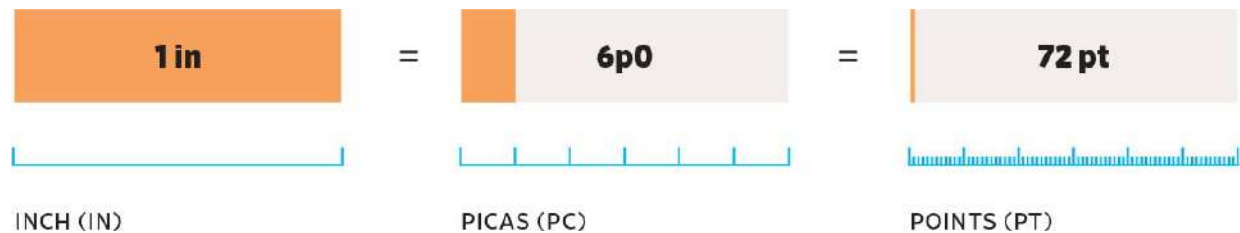

Metric

The Metric System’s standard fixed value units are based on millimeters (.001 meter, 0.1 centimeter, 0.0394 inch). One millimeter is equal to 2.85 American–British points.

While the size of type has always been measured in points, there have been variations in the past as to the precise size of a point. This discrepancy was resolved in 1985 by both Adobe and Apple when they agreed that the measurement of a point would be exactly 1/72 of an inch, so that it corresponds with both Adobe PostScript and Mac screens, which also have a 72-pixel-per-inch (PPI) resolution.

ABSOLUTE MEASUREMENT: METRIC

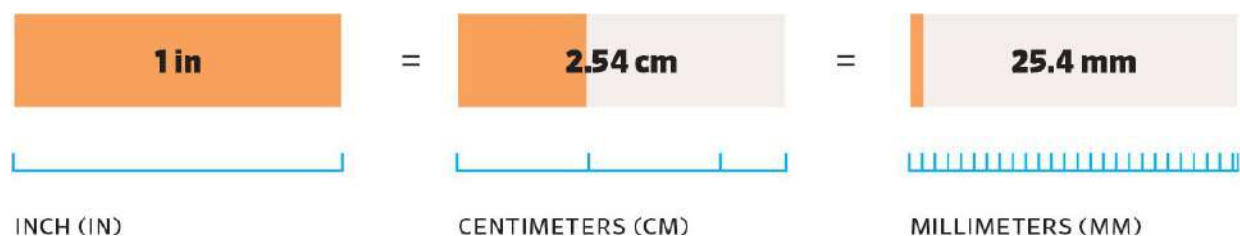

Relative Measurement Systems

In typography, certain rational values applied to character spacing, fractions, and

dashes are directly linked to the type size in which they are set, which is measured by a relative (rather than absolute) measurement system. As the size of the typeface changes, so does the relative size of its typographic characters and glyphs.

Type measurements are relative to the specific point size of the typeface being set. For example, an em set in a seventy-two (72) point typeface is seventy-two (72) points. An en is equal to half an em.

The following relative type measurements are used to set dashes, fractions, and spacing:

RELATIVE MEASUREMENT

6 pt  6 PT

12 pt  12 PT

24 pt  24 PT

48 pt  48 PT

60 pt  60 PT

72 pt  72 PT

Em

An em is a relative unit of type measurement derived from the width of a font's widest letter, invariably the square body of the cast uppercase "M." An em space equals the size of a given typeface; for example, the em space of a seventy-two (72) point typeface is seventy-two (72) points. Traditionally, an em space is used for paragraph indents and denoting nested clauses in North America.

EM, EN, AND UNIT



EM SPACE
1 EM = 50 PT



EM DASH
1 EM



EN DASH
½ EM

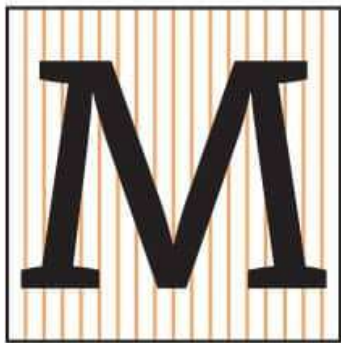

18 UNITS



14 UNITS



12 UNITS



7 UNITS

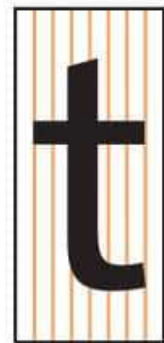

8 UNITS

En

An en is a unit of relative type measurement equal to half the width of an em dash or em space. The en dash is used in Europe to denote nested clauses. It can also denote a range, such as in “chapters 10–11” and “1975–1981.” An en dash can also mean “and,” for example, between two surnames on the spine of a book.

The point system can also be used to specify a line measure, a column width, and a maximum line length of a typeface. This length is commonly expressed using the pica, a type measurement of twelve (12) points, giving six (6) picas to one inch. It is sometimes referred to as a pica em, or simply an em. While it is now increasingly common for column widths to be expressed in millimeters, pica ems remain in use as a system of line measure. The line measure used throughout this book can be described as being set 9/14 to a column width of 15 pica ems (2.5 inches/65 mm).

pica ems (2.5 inches/63 mm).

In the context of line measurement, the term “em” refers to a twelve (12) point em (a pica), but the term is more broadly used to describe a measure equal to the body height of the type of any size (based upon the square proportions of a classical capital M). A thirty (30) point em is therefore thirty (30) points in width. Both the em (a measure equal to the body height) and the en (a measure that is half the body height) are used to describe the width of dashes and spaces.

Unit

The em is subdivided into units. This is a term used for specifying in detail the individual widths of letters and the spaces between them, based on the division of them into fractions. Until recently, it was common for this measurement to be expressed through the division of the em into anything between eighteen (18) and sixty-four (64) units. However, depending on the software used, current PostScript technology uses a division of one thousand (1,000), giving one thousand (1,000) units to the em.

The resulting type measurement allows for the description of the set width of each letter, that is, the individual measurement of each letter’s width. It also provides a means of describing the space between letters, which can be increased or decreased unilaterally (letter spacing) or adjusted between individual letters (kerning).

Unlike the point, the unit is not a fixed measurement, but a proportional measurement based on the size of type used; for example, ten (10) point type is measured in units of 1,000th of ten (10) points; thirty-six (36) point type is measured in units of 1,000th of thirty-six (36) points. Any adjustment to unit values can therefore be applied consistently across a range of type sizes.

Letter spacing adjustments are specified in different ways by different typesetting systems, but the 1,000-unit em has allowed for unprecedented precision in the adjustment of letter and word space.

Many current software programs also allow for adjustments to set width, extending or condensing the proportions of the character itself. This should be used sparingly, since any change to the proportions of a letterform is in effect a redesign of that typeface.

Standard Measurement Conversions

1 mm = 2.66 didot points

1 mm = 2.845275 pica points

1 mm = 0.0393701 inch

1 didot point = 0.3759398 mm

1 didot point = 1.07001 pica point

1 didot point = 0.0148057 inch

1 pica point = 0.352777 mm

1 pica point = 0.938387 didot point

1 pica point = 0.013888 inch

1 inch = 25.4 mm

1 inch = 67.564 didot points

1 inch = 72 pica points

Proportional Systems

Graphic design is partly an experience of visual balance—of the relationship of its parts to the whole. Perceiving it as anything else is missing its most fundamental visual component, just as painting, sculpture, architecture, music, prose, or poetry are organized and methodically balanced around a hidden sense of true proportion.

Most of what we perceive as pleasing to the eye, as well as balanced and harmonious, has some relationship and connection to the rules of a proportional system.

Proportion is the systematic relationship of one element to another in any given compositional layout. In graphic design, proportion is an essential design and planning principle that is defined as the integral relationship of sizes within a compositional layout. These integral relationships are transparent and function as an underlying framework for all compositional elements.

Proportion also represents the critical relationship of one part of a compositional layout to another part or to the whole of a compositional layout, with respect to its size, quantity, or degree. Generally, the goal of any proportional system is to produce visual coherence, harmony, and integrity among the elements of any compositional layout.

Historical References

Proportional systems have largely shaped our visual world throughout history. For example, they are an intrinsic part of the planning and design of the Great

Pyramid at Giza (ca. 2580–2560 BCE), the Parthenon (447–432 BCE; see [here](#)), Leonardo da Vinci’s *Mona Lisa* (1503), and Michelangelo’s *David* (1501–1504).

THE DIVINE PROPORTION



$$\frac{AB}{AC} = \frac{AC}{CB}$$

Euclid (mid-fourth century–mid-third century BCE), the Greek mathematician who is also known as the “father of geometry,” was the first to put the theory of proportional systems into words and images. He divided a line into two sections in such a way that the ratio of the whole line to the larger part is the same as the larger part is to the smaller. This proportional theory is known as “The Divine Proportion” (see [here](#)).

It is the ratio between two segments or elements of an object such that the smaller (BC) segment is to the larger segment (AB) as the larger segment (AB) is to the sum of the two segments (AC), or $BC/AB = AB/AC = 1.61803$ or $1 + \text{square root of } 5 \text{ over } 2$. For example, dividing a line by this ratio means that the relationship between the greater part of the line and the smaller part of the line is the same as that of the greater part and the whole.

Author, architect, and engineer Vitruvius (Italian, 80–70 BCE) devised a mathematical formula for the division of spatial relationships in a compositional layout. His proportional system, known as the golden section, the golden mean, or the golden rectangle, was based on a set relationship or ratio between the longer and shorter sides of a rectangle, which is the same system used by the Greeks in their orders of architecture (see right).

One of the most universal images representing the visual theory of a proportional system is Leonardo da Vinci’s (Italian, 1452–1519) drawing of the Vitruvian man (see [here](#)), which first appeared in the 1509 book *De divina proportione (On the Divine Proportion)* by mathematician and Franciscan friar Luca Pacioli (Italian, 1445–1517). Da Vinci wrote extensively in his notebooks about the proportions of the human body. It was here that he attempted to codify a proportional system based on his studies of the human form, as well as his

numerous observations and measurements of proportions for all its parts. He referred in these notebooks to the works of Vitruvius.

Many artists of the Renaissance subsequently used proportional systems as a primary design principle in their work. For example, in the fifteenth century, painter and printmaker Albrecht Dürer (German, 1451–1528) determined what characteristics of the human body were visually balanced and beautiful by accurately measuring and documenting the proportions of its parts.

Basic Proportional Relationships

Not obvious, and not hidden, the principle of any proportional system can be simply conveyed. In Priya Hemenway's *Divine Proportion: Phi in Art, Nature, and Science* (2005), she states, "The whole is to the larger in exactly the same proportion as the larger is to the smaller." Its function is to lend insight into the process of design and give visual coherence to compositional layout through visual structure.

In basic proportional relationships, the outer dimensions determine the format of a two-dimensional compositional layout and are its most basic proportion. A square, a vertical rectangle, and a horizontal rectangle are all formats with unique proportions that directly affect particular characteristics of a compositional layout. Its outer proportions or dimensions can have an integral relationship to its internal divisions and alignments. Outer dimensions affect the orientation of the viewer and are often dictated by the nature of the compositional layout's ultimate proportion.

The relationship between outer dimensions and internal divisions can also provide a proportional system for managing design decisions. Some proportional systems have been used for centuries in architecture, art, and design. Those systems are based on ratios—a comparison of one set of sizes or quantities with another. Although these ratios are commonly expressed in mathematical terms, they also can be expressed as visual relationships.

Golden Section

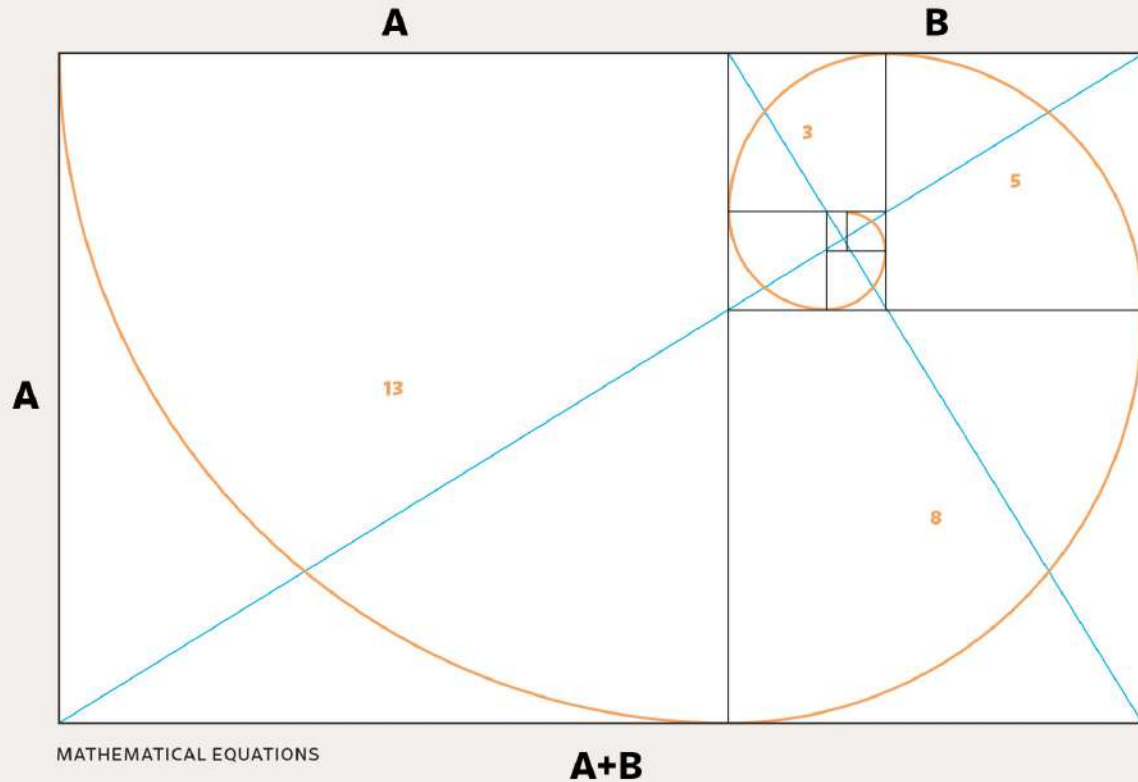

Golden Section

The golden section is a ratio that dates back to the ancient Greeks and its proportional properties possess both aesthetic beauty and structural integrity. Its proportions are based on the approximate ratio of 8:13 and appears in many visual disciplines including art, graphic design, and architecture.

As with most proportional systems, you can use the golden section for establishing harmonious relationships in page proportions, grid formats, and sizes of visual elements in compositional layouts.

The golden section can also be found throughout the natural world, as well as throughout the history of visual and applied arts. This proportional system is

evident in the natural growth structured patterns of pinecones, nautilus shells, honeycombs, seed patterns found in the center of sunflowers, and the human body. It is constructed using a series of extended relationships that possess a strong aesthetic harmony since their interior proportions relate in scale to the proportions of the original square and its extensions.

It can also be extended to construct the golden rectangle, which was used by the Greeks as the basis for the majority of their city planning and architecture. The architect Phidias (Greek, 480–430 BCE), the master planner of the Acropolis at Athens, and Ictinus (Greek, ca. 400 BCE), the architect of the Parthenon (see [here](#)), both valued and employed the golden section in their work. Renaissance artists used it to create overall harmony and balance in works of painting, sculpture, and drawing. Antonio Stradivari (Italian, 1656–1737) used it in the design and construction of his musical instruments, including his Stradivarius violins. It was also used in the planning and design of Stonehenge (Wiltshire, United Kingdom, 1500 BCE), Chartres Cathedral (Chartres, France, 1220), the LCW (aka Lounge Chair Wood) Chair (1946) designed by Charles Eames (American, 1907–1978), and the Apple iPod MP3 Player (2001) designed by Jonathan Ive (British, b. 1967). Even today, graphic designers use the golden section as an optimal format for print and digital media.

Compositional layouts based on these proportions are particularly pleasing to the eye. For example, the golden section forms the basis of ISO Standard Paper Sizes (see [here](#)) due to its harmonious proportions, and its principles are used as a means of achieving balanced compositions. Unfortunately, a graphic designer's reliance on this proportional system has lessened due to the features and options of linear measurements made available in current desktop publishing software.



Images: ©randydellinger, ©simoningate, ©Maja Nuicé.

A cross-section of a nautilus shell, a spiral cactus, and a sunflower all show the 8:13 golden section ratio in their growth and formation patterns.





Constructing the Golden Section Rectangle

Anyone can construct the golden section rectangle and use it for developing meaningful spatial relationships in any compositional layout.

1.

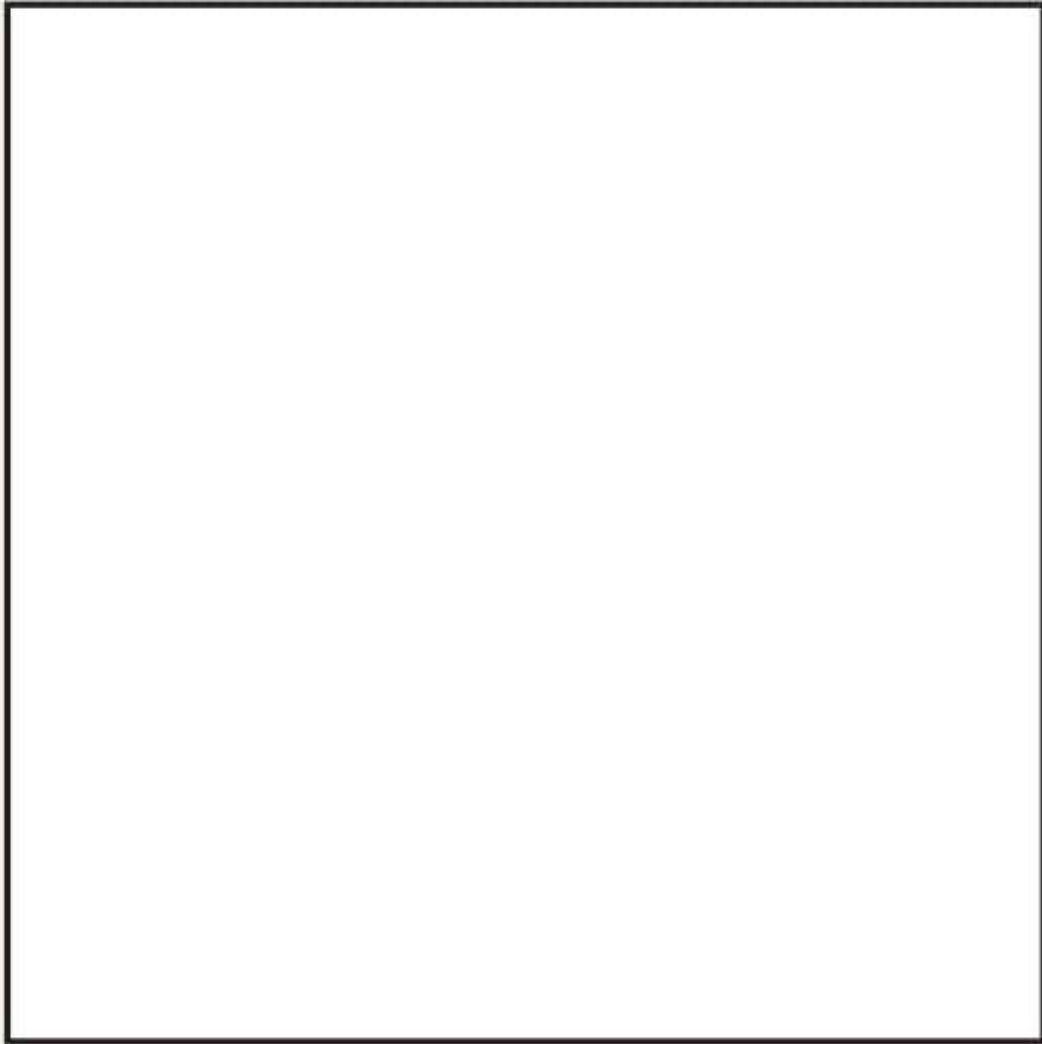

Step 1 **Construct a perfect square.**

2.

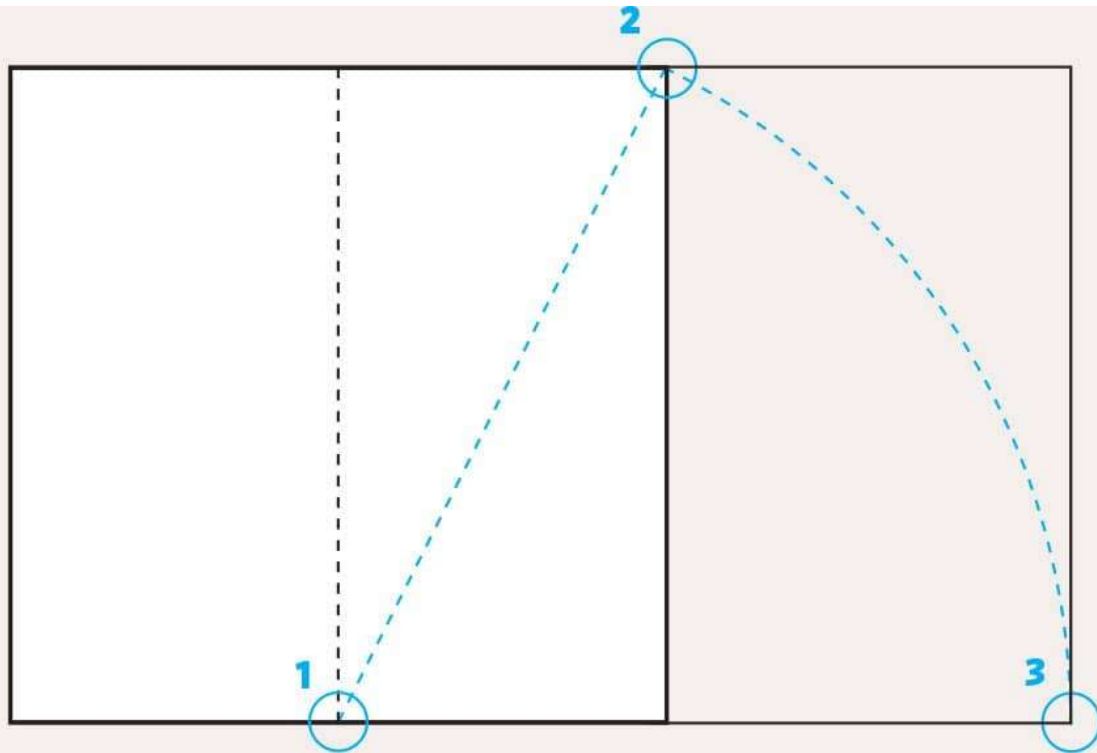

Step 2 Using a line, draw a diagonal from the midpoint of one side of the square (1) to an opposite corner (B); at midpoint (2) draw a radius of an arc to define the sides of a new golden section rectangle (3).

3.

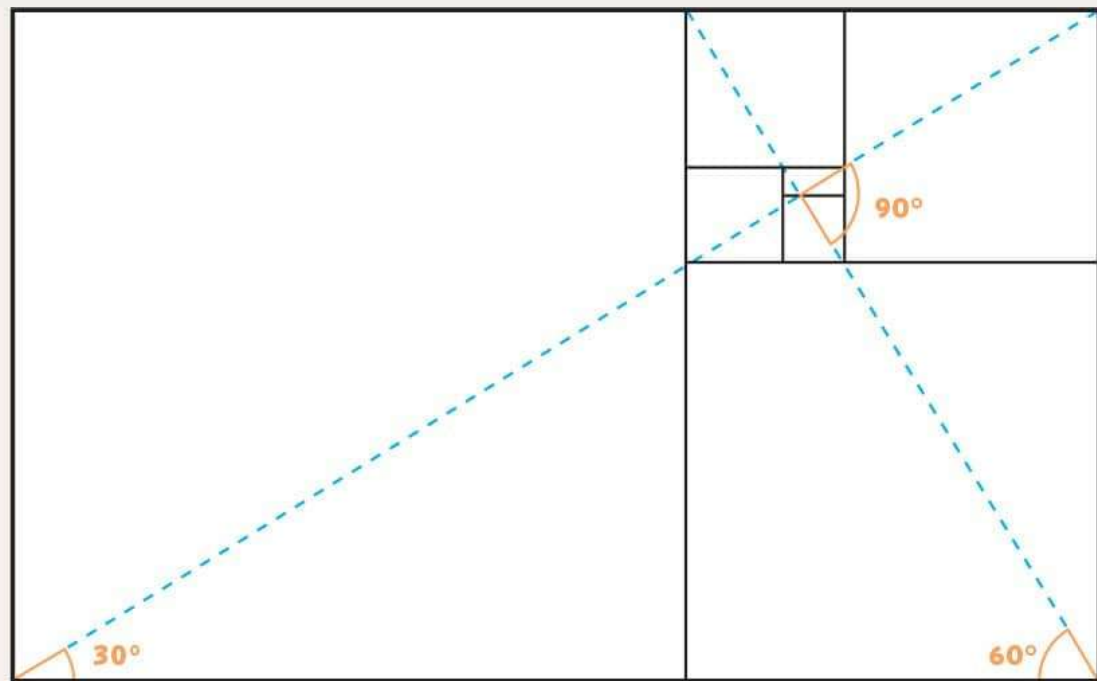

Step 3 Draw a line from the opposite corners of each rectangle to further subdivide the rectangle into smaller proportional golden section rectangles.

Note: The same golden section rectangle subdivision diagram shown in *Step 3*, can be used to construct a golden section spiral (see [here](#)). Use the length of the sides of the squares of the subdivision as a radius of a circle.

GOLDEN SECTION SPIRAL WITH PROPORTIONAL SQUARES

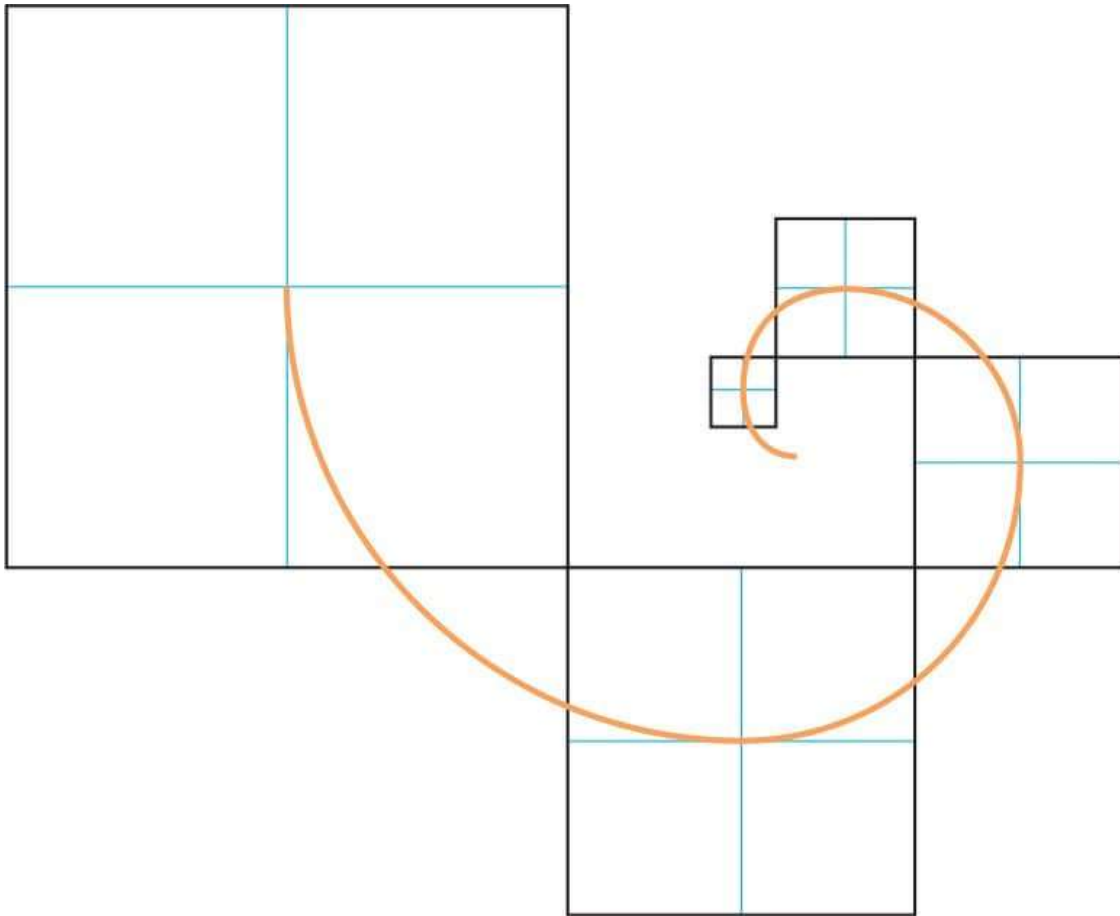

A golden section rectangle is one whose side lengths are in the golden ratio of $1 + \sqrt{5}$ over 2 or 1:1.61803. The golden section rectangle is also a proportional system with unique reciprocal characteristics. For example, when the golden section rectangle is subdivided into a smaller proportional rectangle and the remaining subdivision is a square, this characteristic is identified as a golden section spiral. Its squares proportionally decreasing in size produce a spiral by using a radius the length of the sides of the square (see below left). This logarithmic spiral based on golden section proportions is reminiscent of the growth patterns of shells, as evident in a cross section of a nautilus shell (see [here](#)).

This proportional relationship has also been identified over the centuries as the golden mean, golden number, golden ratio, golden proportion, divine proportion, and *sectio aurea*.

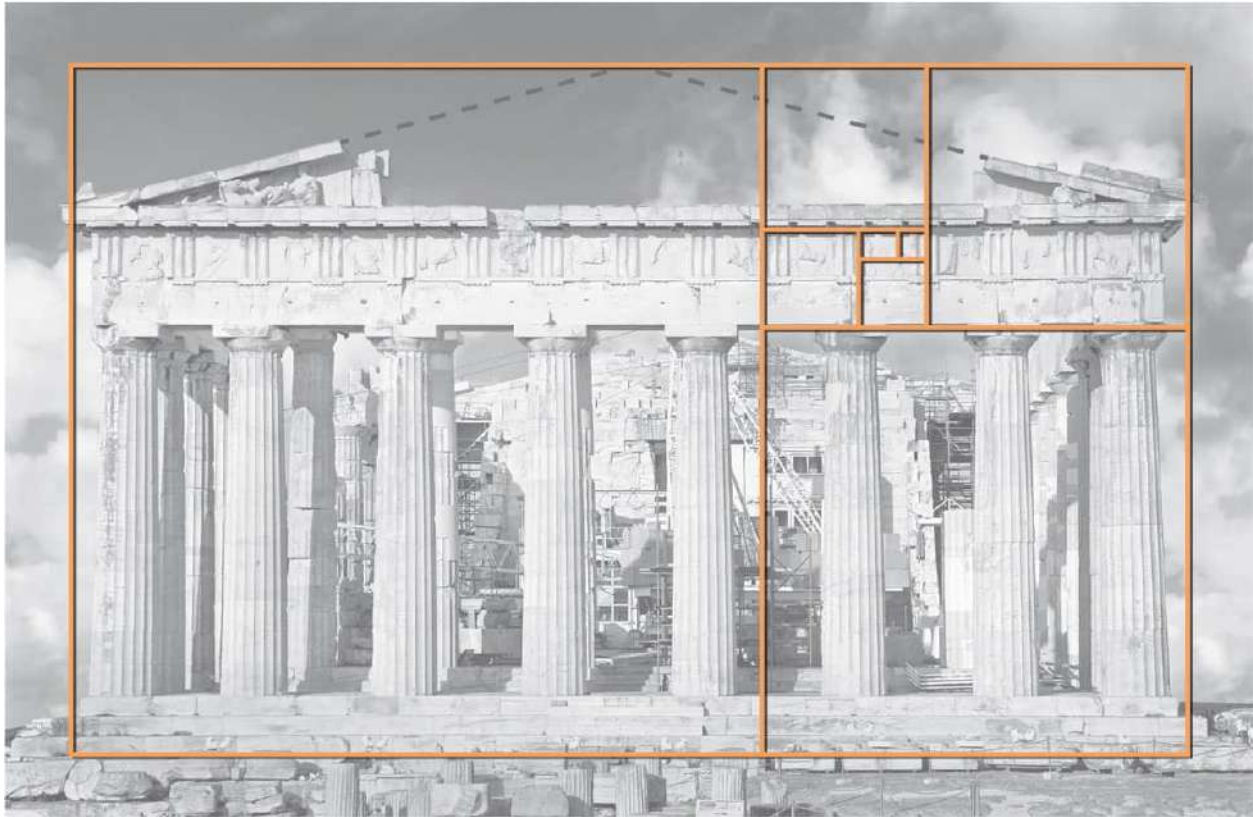

Image: ©lavendertime.

Golden Section proportions were an intrinsic part of the planning and design of the Parthenon (447–432 BCE).

Fibonacci Sequence

Named after noted mathematician Fibonacci, also known as Leonardo of Pisa (ca. 1175–1250), the Fibonacci sequence is a series of rationally spaced numbers in which each number is the sum of the preceding two numbers, such as 0, 1, 1, 2, 3, 5, 8, 13, 21, 34, 55, 89, 144, 233, 377, and so on. This number series and sequence has a direct relationship to the Golden Section and its 8:13 proportional ratio (see right).

Fibonacci observed this pattern and sequence in the natural world and can be found in human proportions and the growth pattern of many living plants, animals, and insects. This proportional system has been used by artists, architects, writers, poets, and composers throughout history to enhance and further the beauty and dynamism in their work. For example, it is thought that

the author Virgil (Italian, 70–19 BCE) used the Fibonacci Sequence to structure his poetry in the *Aeneid*, and that Mozart (Austrian, 1756–1791) relied upon the sequence in his musical compositions.

The Fibonacci sequence provides you with a proportional system of balanced and harmonious relationships that can be used to create a wide array of compositional layouts that are spatially related and possess harmonious and pleasing proportions.

Fibonacci Sequence

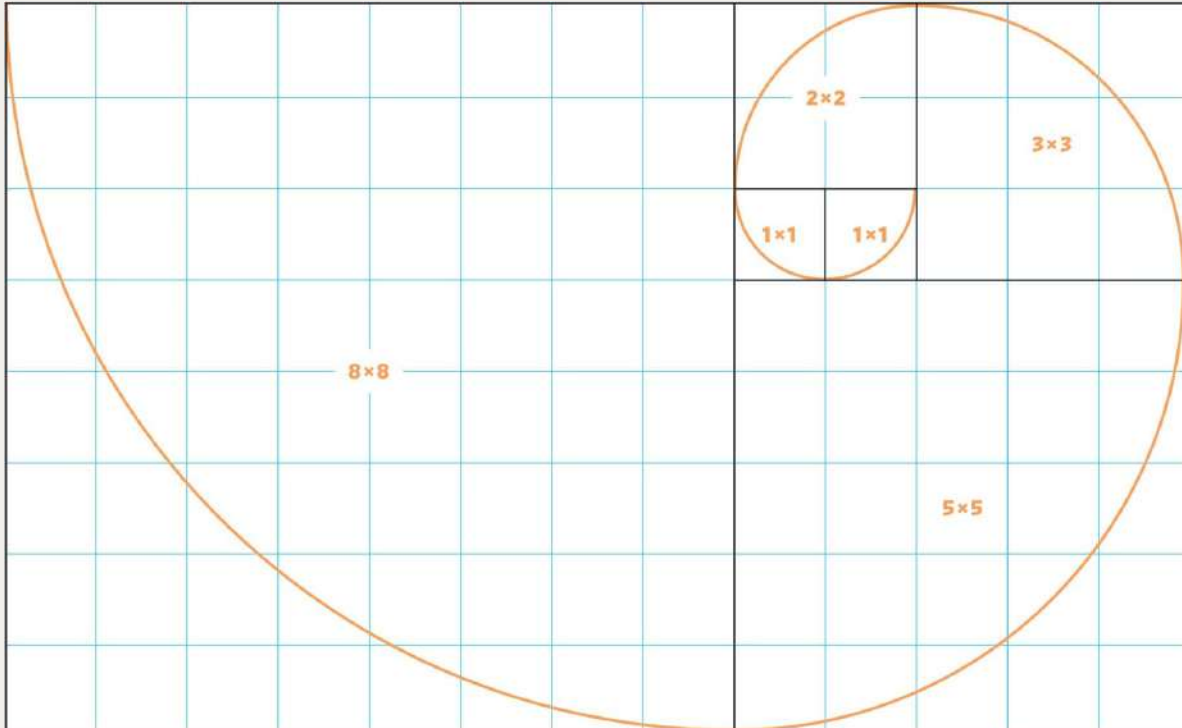

NUMERICAL FORMULA

$$0 + 1 = 1$$

$$1 + 1 = 2$$

$$2 + 1 = 3$$

$$2 + 3 = 5$$

$$3 + 5 = 8$$

$$5 + 8 = 13$$

$$8 + 13 = 21$$

$$13 + 21 = 34$$

$$21 + 34 = 55$$

NUMERICAL SEQUENCE

0, 1, 1, 2, 3, 5, 8, 13, 21, 34, 55, 89, 144, 233, 377, 610, 987, 1,597, 2,584, 4,181, 6,765, 10,946, 17,711, 28,657, 46,368, 75,025, 121,393...

Historical Influence:

Divina proporción tipográfica

Divina proporción tipográfica (*Typographical Divine Proportion*) was first published in 1947 and documented the analysis of Renaissance books designed by notables such as Johannes Gutenberg (German, ca. 1395–1468), which utilized the golden ratio (2:3). Its author and designer, Raúl Rosarivo, asserted that Gutenberg and his contemporaries used the golden ratio (or “secret number” as the author called it) to create harmonic spatial relationships on the pages of their printed works.

Raúl Mario Rosarivo (Argentine, 1903–1966) was a typographer, researcher, graphic designer, poet, painter, and illustrator known for his extensive work on the analysis of the Gutenberg Bibles. For many years, Rosarivo was the General Director of the Talleres Gráficos de la Provincia de Buenos Aires (Buenos Aires Provincial Graphic Workshops).

Using only a drafting compass, ruler, and standard measuring units, Rosarivo determined that there was a proportional system used by Gutenberg that could be applied to a page’s compositional layout. His system is defined by dividing the height and width of a page in nine sections or ninths (see diagram), with diagonal lines defining the page’s active text block height and width which is the 2:3 ratio.

This proportional system influenced many twentieth-century graphic designers, including Jan Tschichold (German, 1902–1974), who based his golden canon of page construction on Rosarivo’s analysis. Tschichold’s page construction combined with Rosarivo’s division of a page into ninth’s is also equivalent to the 2:3 page ratio and the 2:3:4:6 margin proportions found in the Van de Graaf canon (see [here](#)).

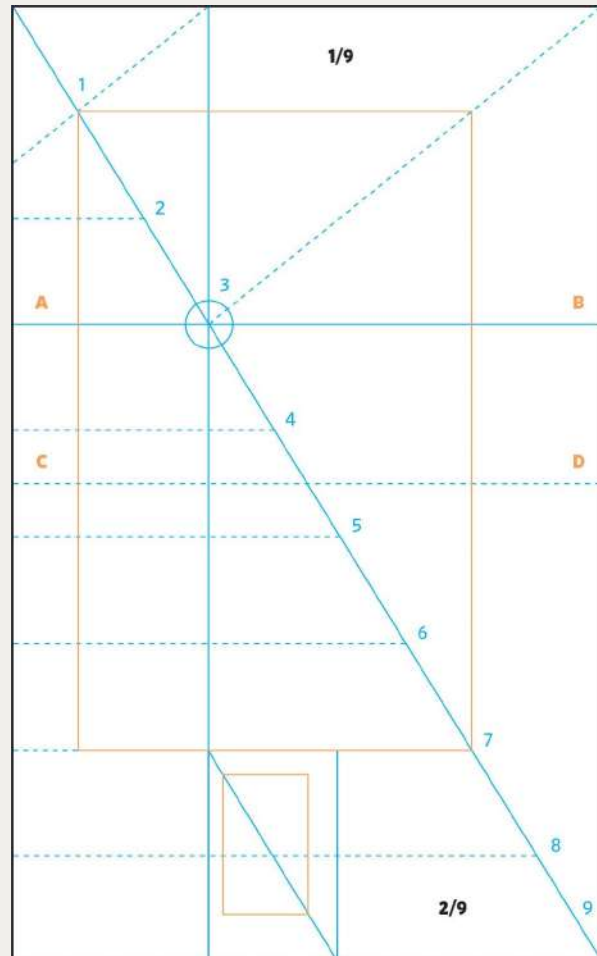

Dynamic Rectangles

The proportional system of dynamic rectangles was first introduced by author and educator Jay Hambidge (Canadian, 1867–1964) in his 1926 book *The Elements of Dynamic Symmetry*. By analyzing classical Greek buildings such as the Parthenon (447–432 BCE; see [here](#)), he proposed that proportion and symmetry found in Greek architecture, art, and sculpture were based on the principles of arithmetic and geometry.

A dynamic rectangle is a right-angled, four-sided figure (a rectangle) with dynamic symmetry, which in this case, means that its aspect ratio (height divided by width) is a distinguished value in dynamic symmetry, a proportioning system and natural design methodology. These dynamic rectangles begin with a square, which is extended (using a series of arcs and cross points) to form the desired figure, which can be the golden section rectangle (1:1.618 ...), the 2:3 rectangle, the double square (1:2), or a root rectangle (1 Φ , 1:2, 1:3, 1:5, etc.).

In his book, Hambidge visually linked the golden section rectangle with a logarithmic spiral. He also placed a strong emphasis on the diagonal of a dynamic rectangle, which when connected to a perpendicular line that lead to one of the rectangle's corners creates a "harmonic subdivision."

Dynamic rectangles are a series of root rectangles that extend from a diagonal of a rectangle, creating the same proportional width-to-height ratio as the others, thereby producing a variety of harmonious subdivisions and combinations that are always related to the proportions of the original rectangle (see [here](#)). This proportional system provides you with a highly effective and useful tool based on geometric proportions rather than actual measurements which can be used to establish sizes and proportions of formats and visual elements in compositional layouts.

Dynamic Rectangles

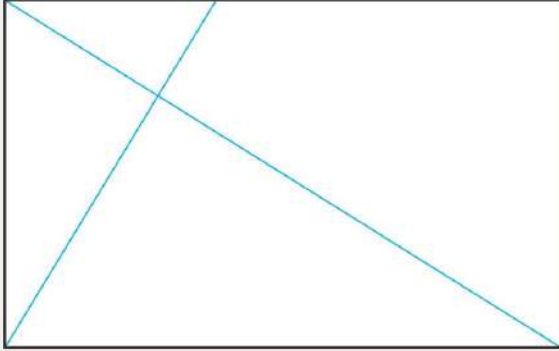

GOLDEN SECTION DYNAMIC RECTANGLE 1

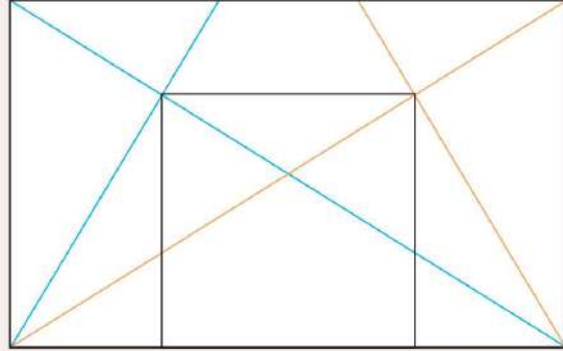

WITH HARMONIC SUBDIVISIONS

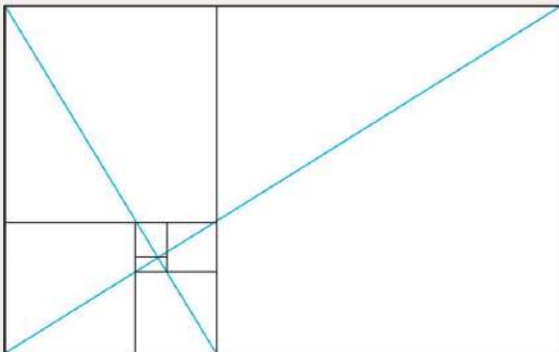

GOLDEN SECTION DYNAMIC RECTANGLE 2

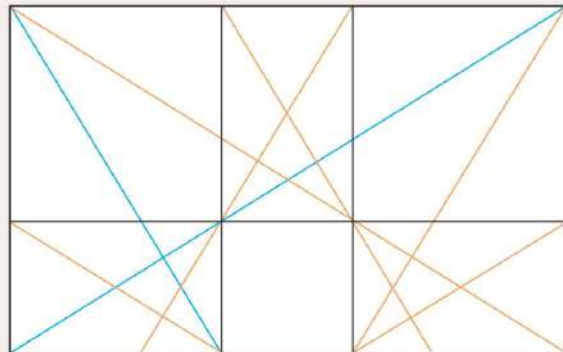

WITH HARMONIC SUBDIVISIONS

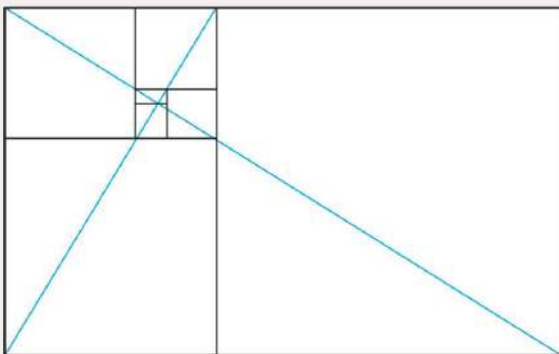

GOLDEN SECTION DYNAMIC RECTANGLE 3

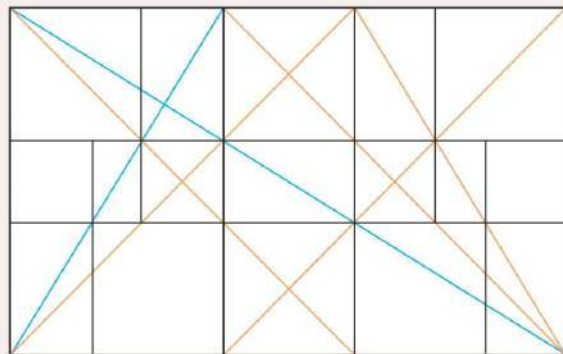

WITH HARMONIC SUBDIVISIONS

Related Systems

There are several other related proportional systems that are relevant and useful tools for you to consider when in need of a methodology for developing page

tools for you to consider when in need of a methodology for developing page layouts, formats, and grids. These related systems are:

Van de Graaf Canon

The Van de Graaf canon is a proportional system that provides you with a methodology to construct a compositional page layout with optimum proportions for page margins and live text areas (see [here](#) to [here](#)). This canon is a historical reconstruction of a proportional system that may have been used to organize a page in pleasing proportions, as is evident in medieval manuscripts and incunabula, as well as in the work of early bookmakers and publishers such as Johannes Gutenberg (German, 1395–1468).

Using this system results in a 2:3 page ratio where the live text area and page size are the same proportions and the height of the live text area is the same measure as the page width. The page's overall margin proportions are 2:3:4:6 (inner:top:outer:bottom), where the inside margin is half the outside margin, and the top margin is half the bottom margin.

Noted twentieth-century graphic designers, such as Jan Tschichold (German, 1902–1974), were influenced by the Van de Graaf Canon and relied upon it extensively in their work.

Constructing the Van de Graaf Canon

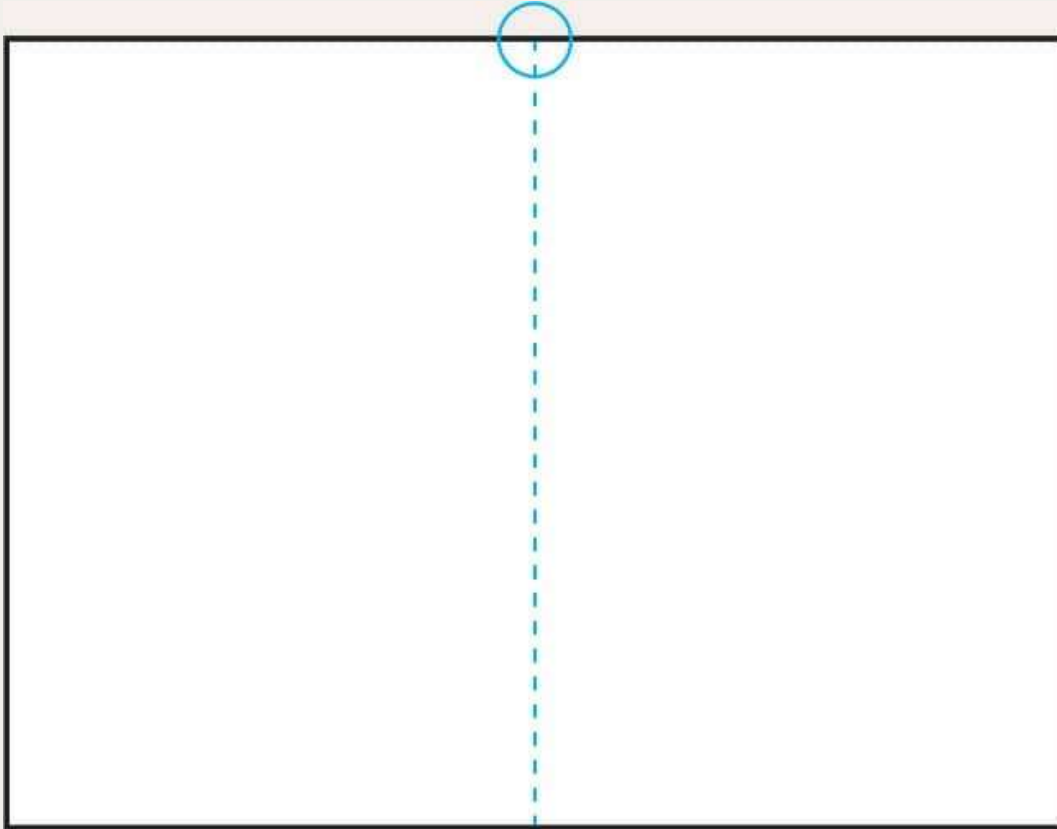

Step 1 **Draw a vertical line to divide the page into two equal, vertical sections.**

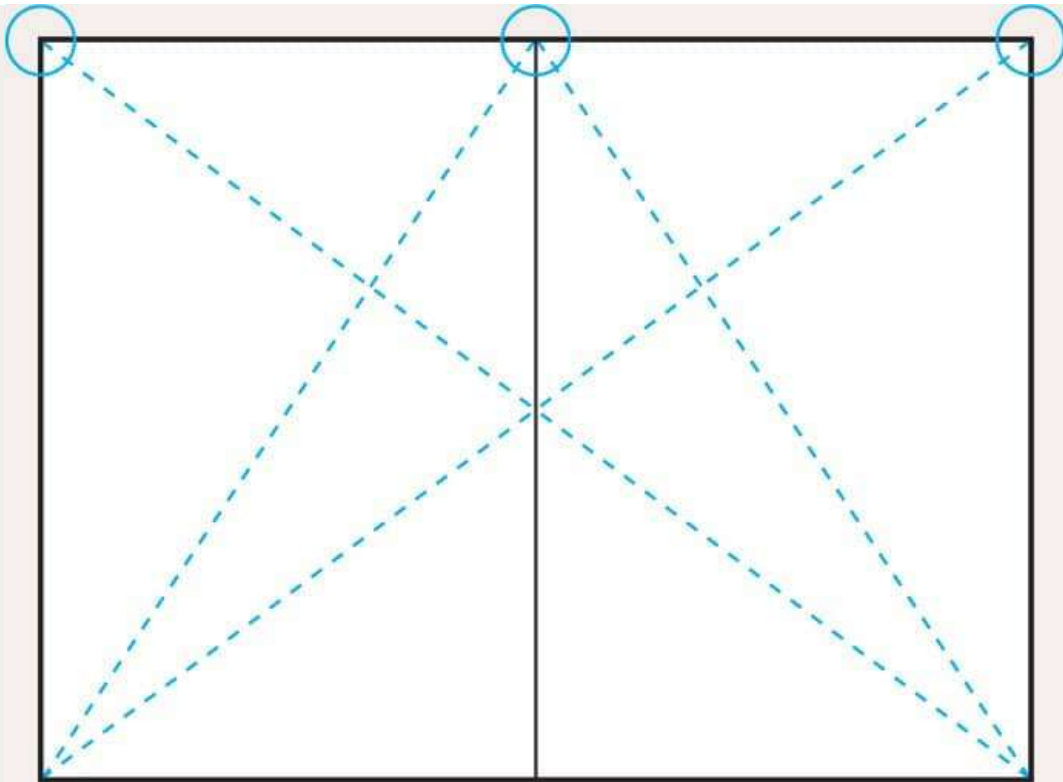

Step 2 **Draw two diagonal lines across the width of the page; then from the top of the vertical center line draw two diagonal lines across the page to create the first two intersection points.**

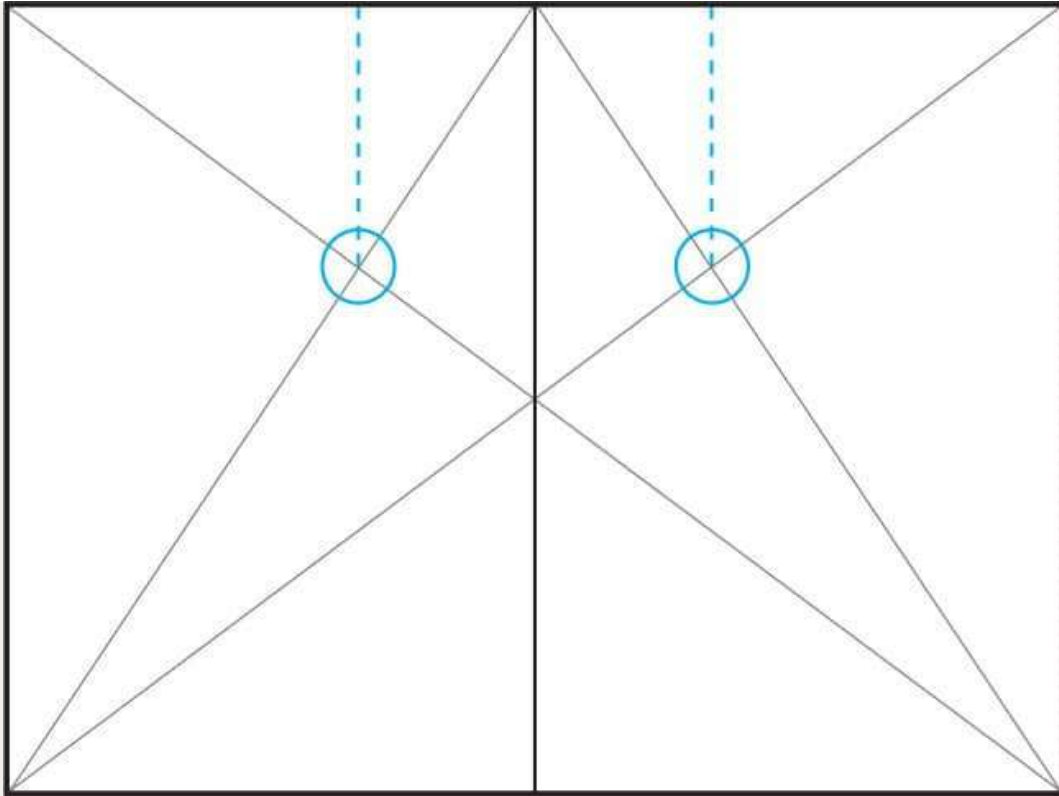

Step 3 **From both intersection points draw vertical lines upwards to the top edge of the page.**

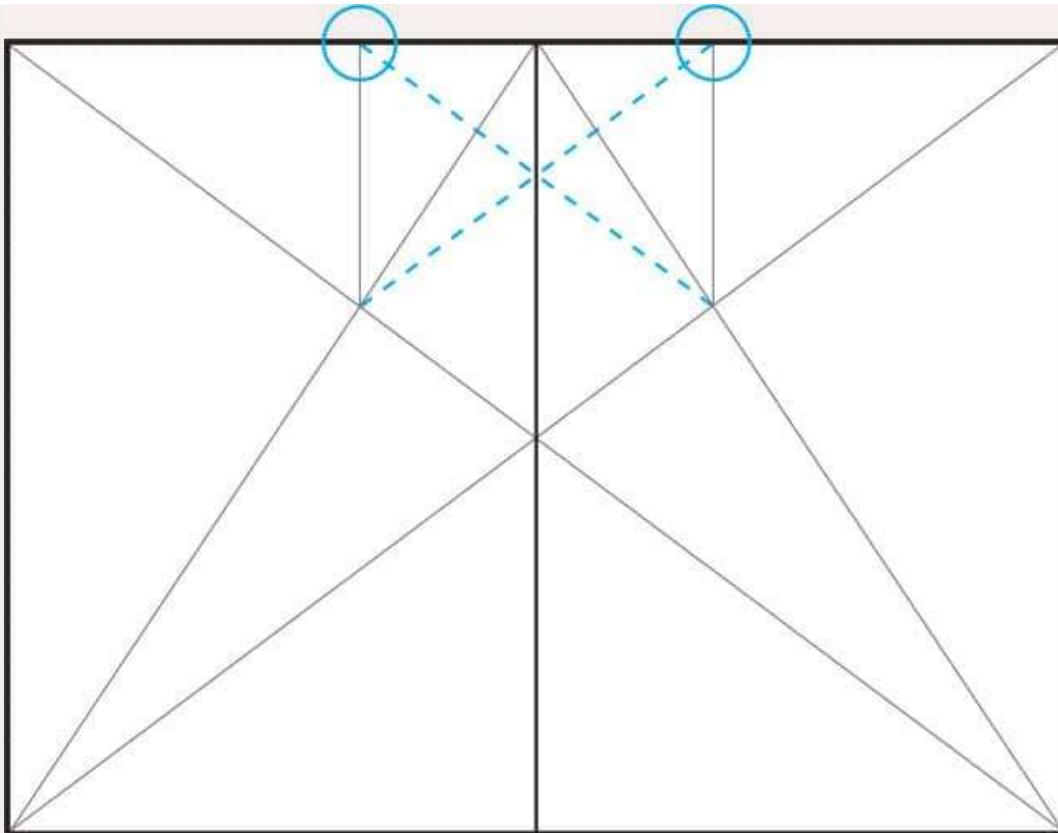

Step 4 **Where the vertical line meets the top edge of the page, draw lines diagonally across to each intersection point to define the two key points on the Van de Graaf canon.**

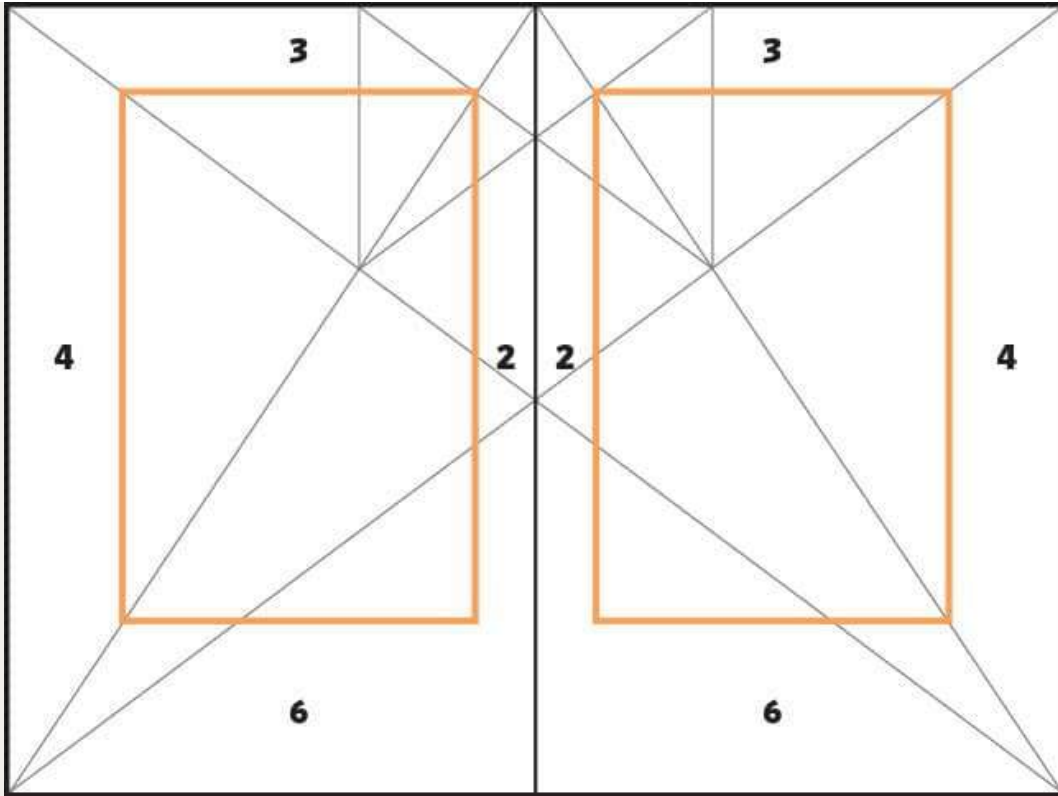

Step 5 From these two key points, draw lines horizontally and vertically to where these two lines intersect the diagonal lines and delineate each page text area. Across the double page spread, this also defines a combined central inner margin equal to the page's outer margin.

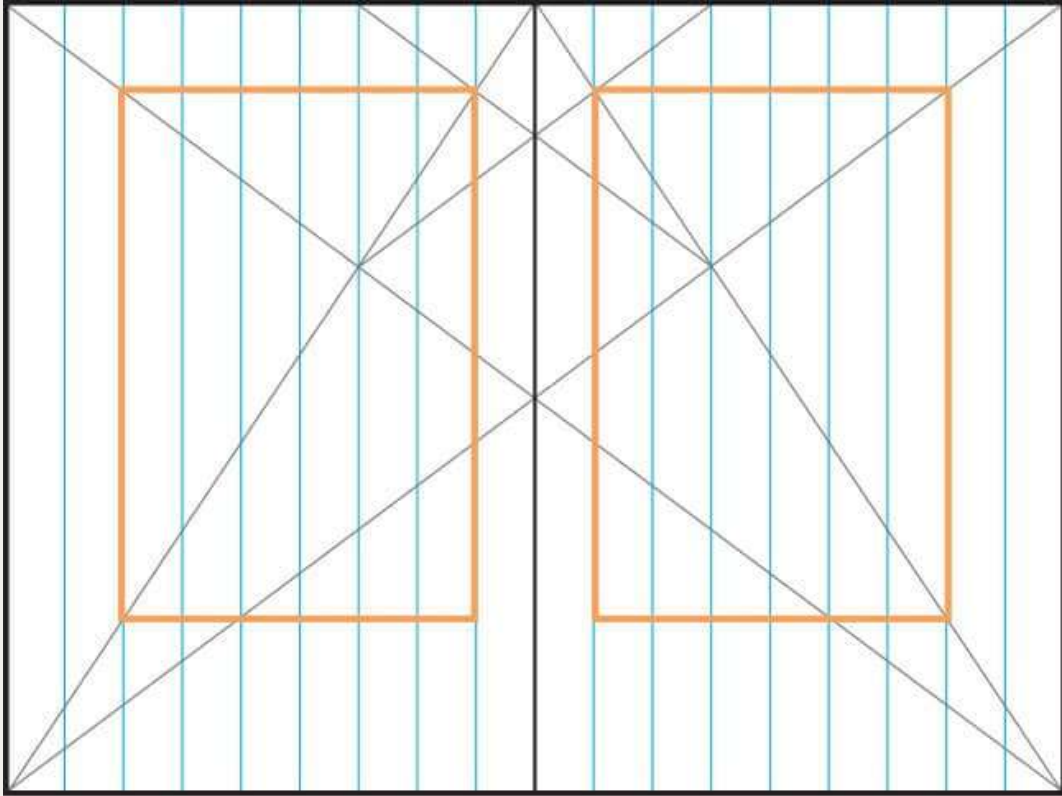

Step 6 **The width of the page's inner margin is used to divide the page into nine equal, vertical columns.**

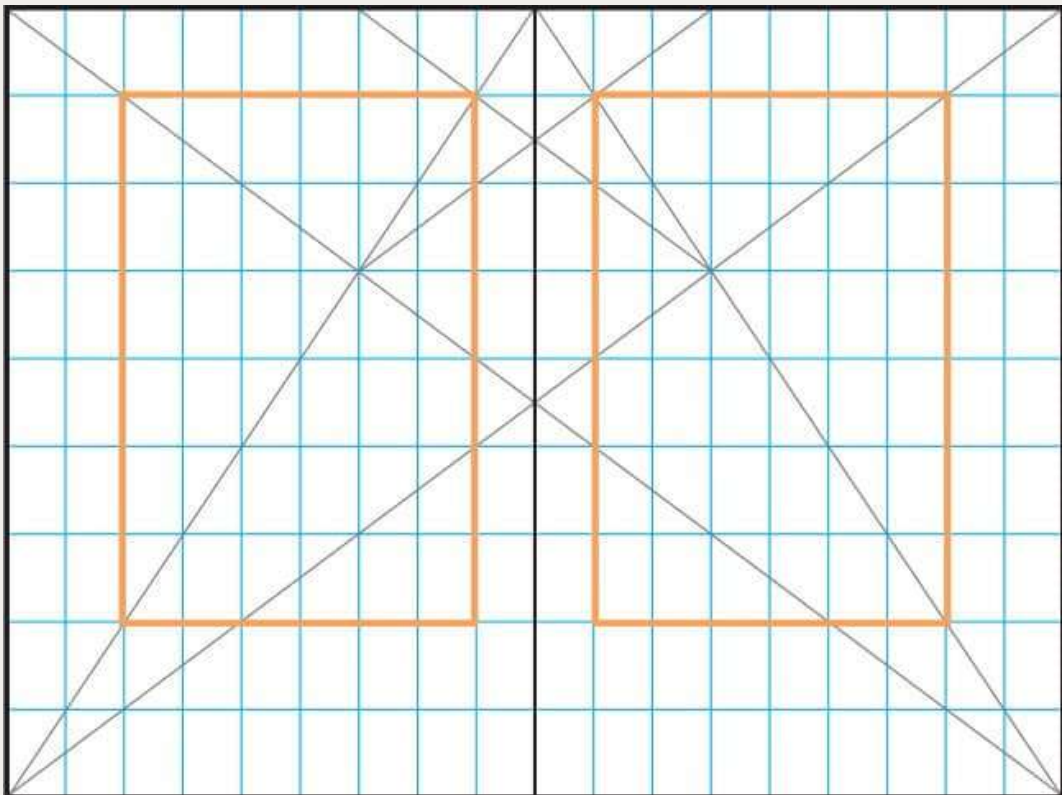

Step 7 The height of the page's top margin is used to divide the page into nine equal, horizontal rows.

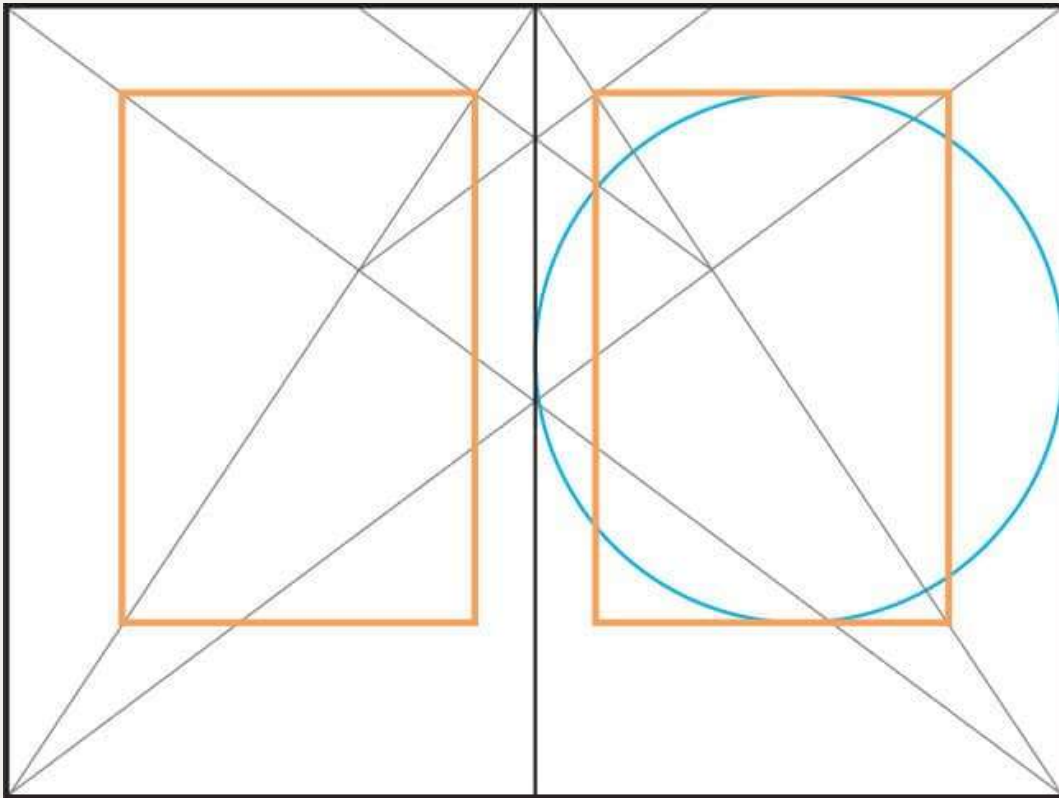

Step 8 A circle encompassing the diameter of the page's width is an alternative method for creating the same page proportions.

Villard Diagram

Another proportional system is based on architect Villard de Honnecourt's (French, 1200–1250) Villard diagram in which he divided a straight line into logical and harmonious divisions of thirds, fourths, fifths, and so on.

This proportional system provides you with a methodology to create a wide array of grid structures including a 6×6 module, a 9×9 module, and a 12×12 module grid (see [here](#) to [here](#)). Based on the same diagonal structure that Van de Graaf used with his Canon, Villard's proportional system relies on intersection points from which horizontal and vertical lines are extended to define margins and the hypotenuse of a triangle. A focal point is then established at the intersection where the hypotenuse of the triangle cuts the diagonal descending from the top of the spine. From this point, vertical and horizontal lines are projected to define a text block.

The Villard diagram can be used to create different-sized text block areas, all of which have margins in 2:3:4:6 ratios.

Constructing the Villard Diagram

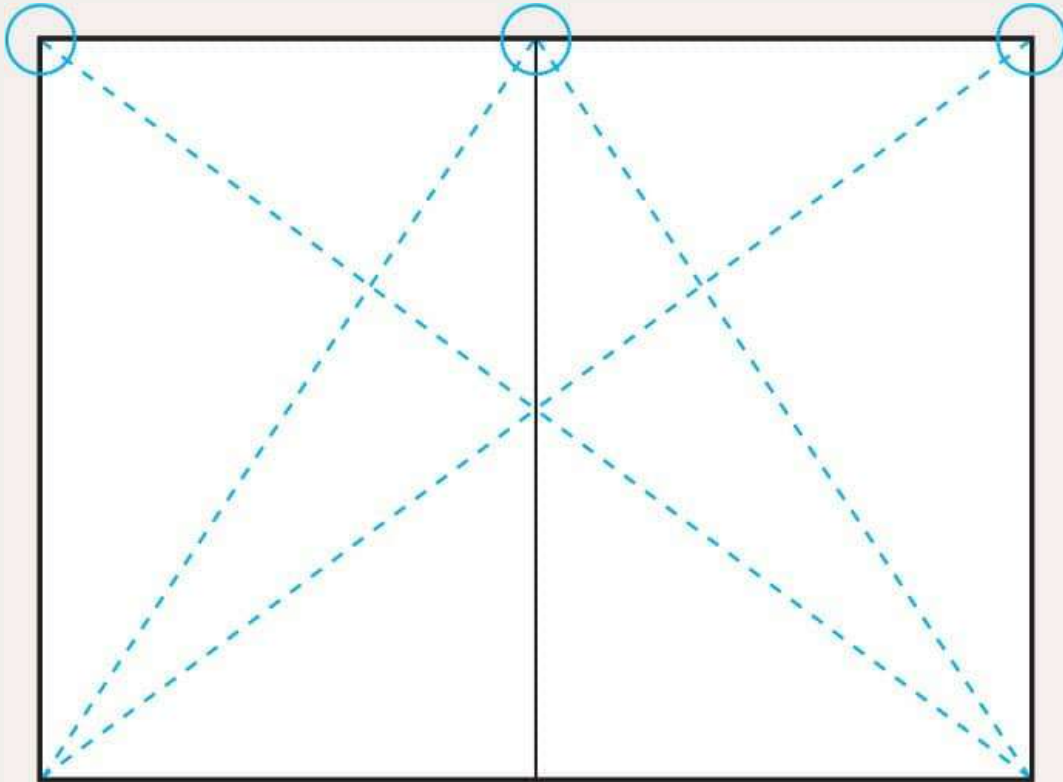

Step 1 **Draw two diagonal lines across the width of the page; then from the top of the vertical center line draw two diagonal lines across the page to create the first two intersection points.**

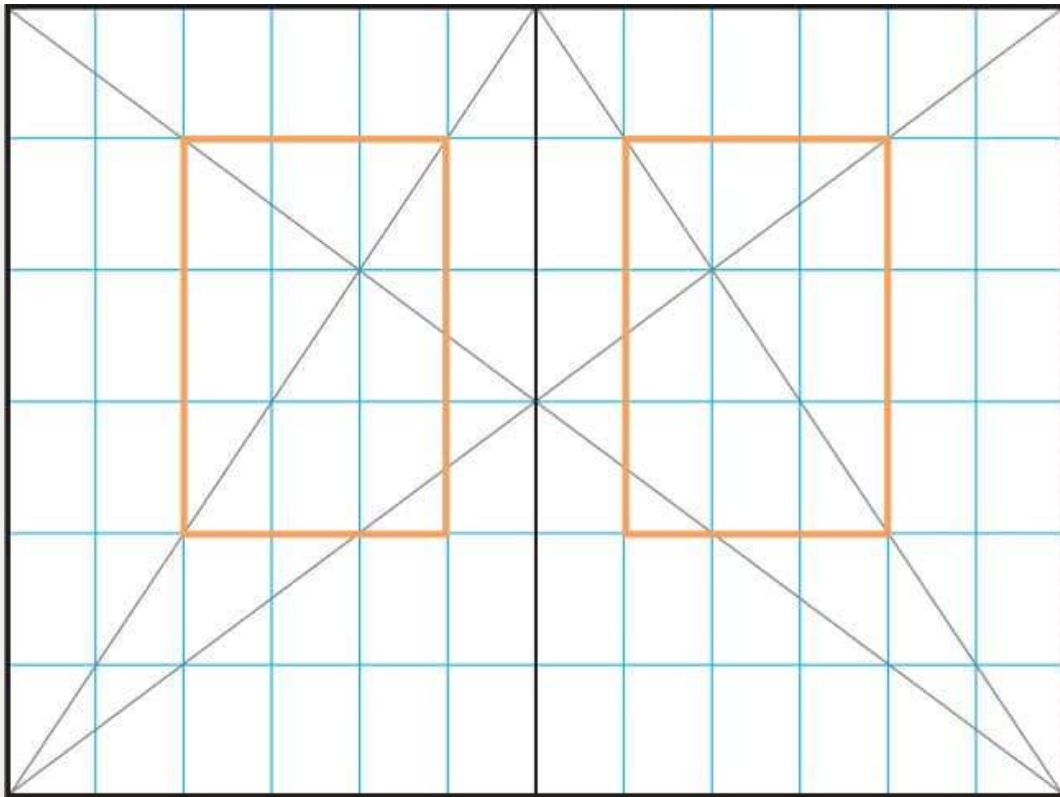

6x6 GRID, BASED ON A 1/3RD TRIANGLE

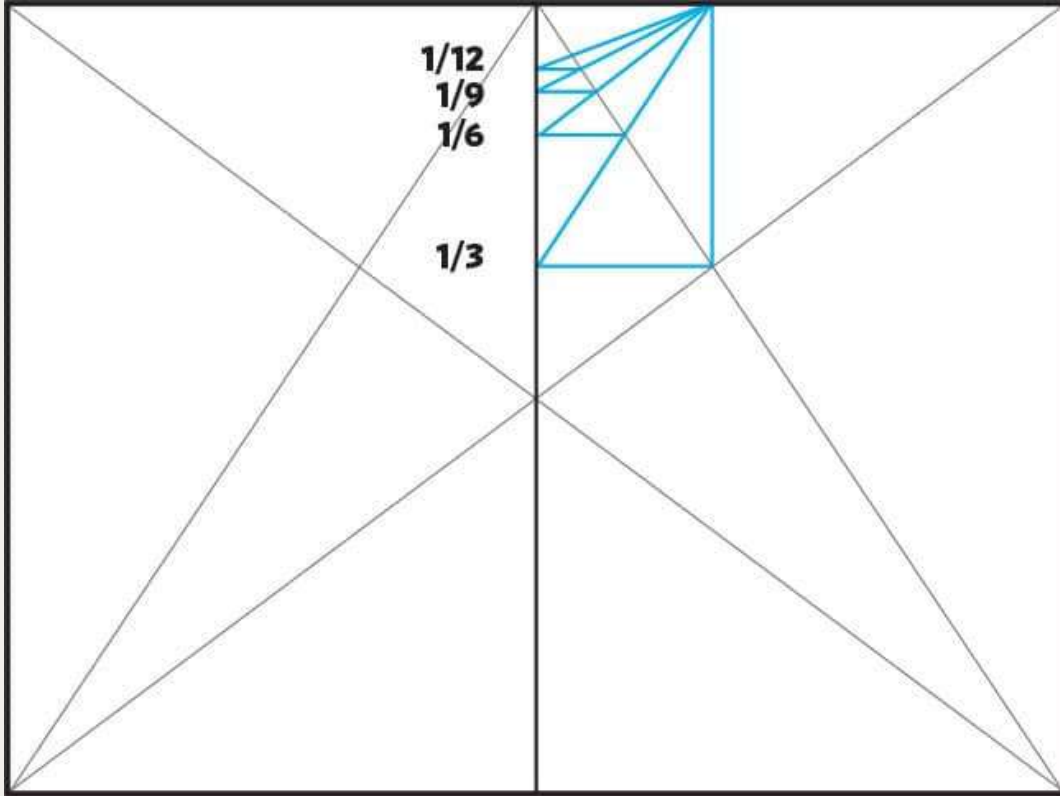

Step 2 **Extend horizontal and vertical lines to define margins and the hypotenuse of a triangle. A focal point is then established at the intersection where the hypotenuse of the triangle cuts the diagonal descending from the top of the spine.**

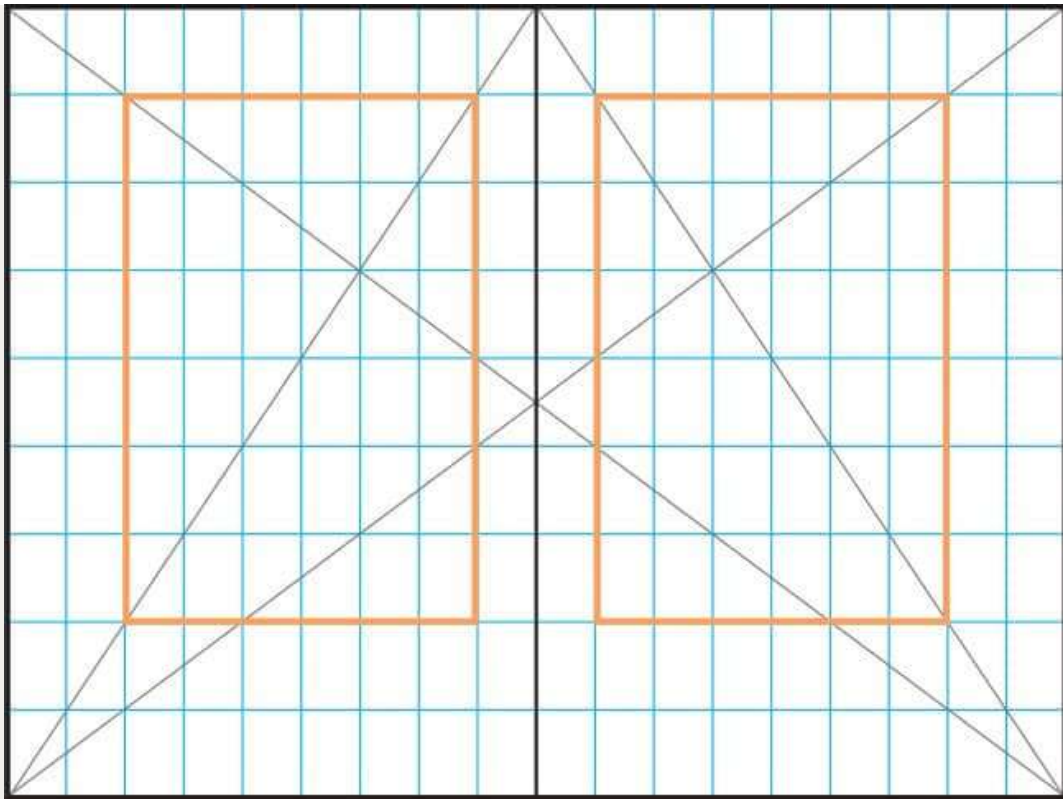

9x9 GRID, BASED ON A 1/6TH TRIANGLE

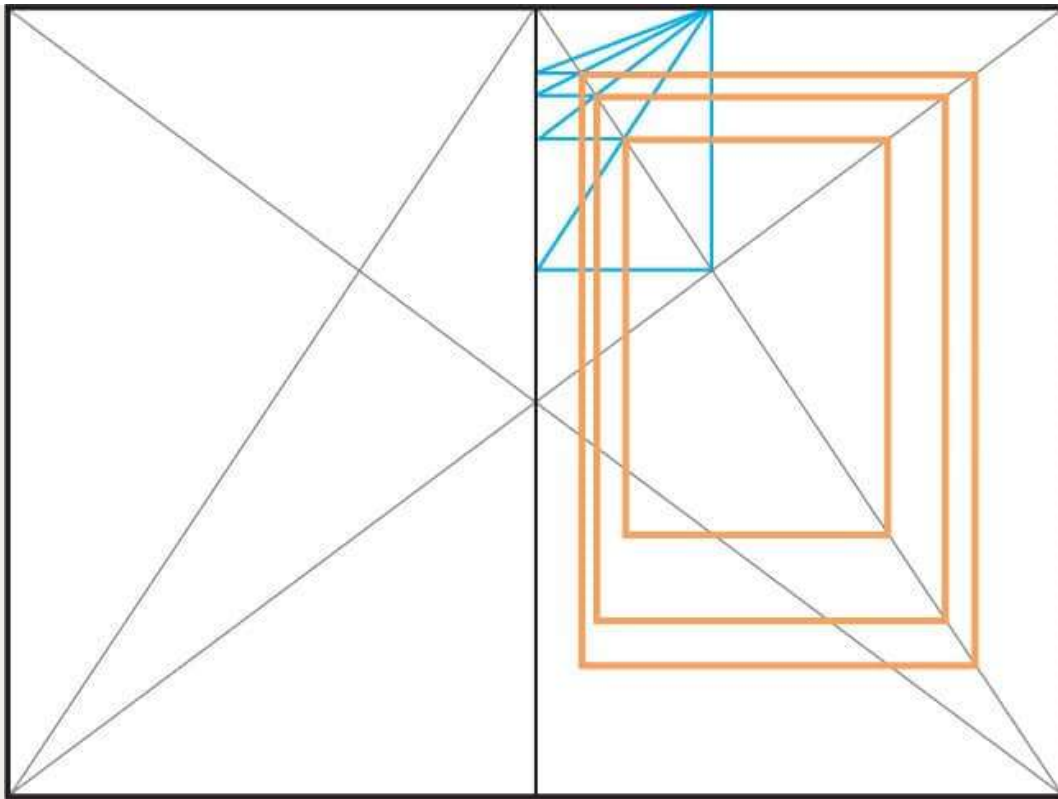

Step 3 **Draw lines horizontally and vertically from the intersection points of the triangles to delineate a wide array of text areas.**

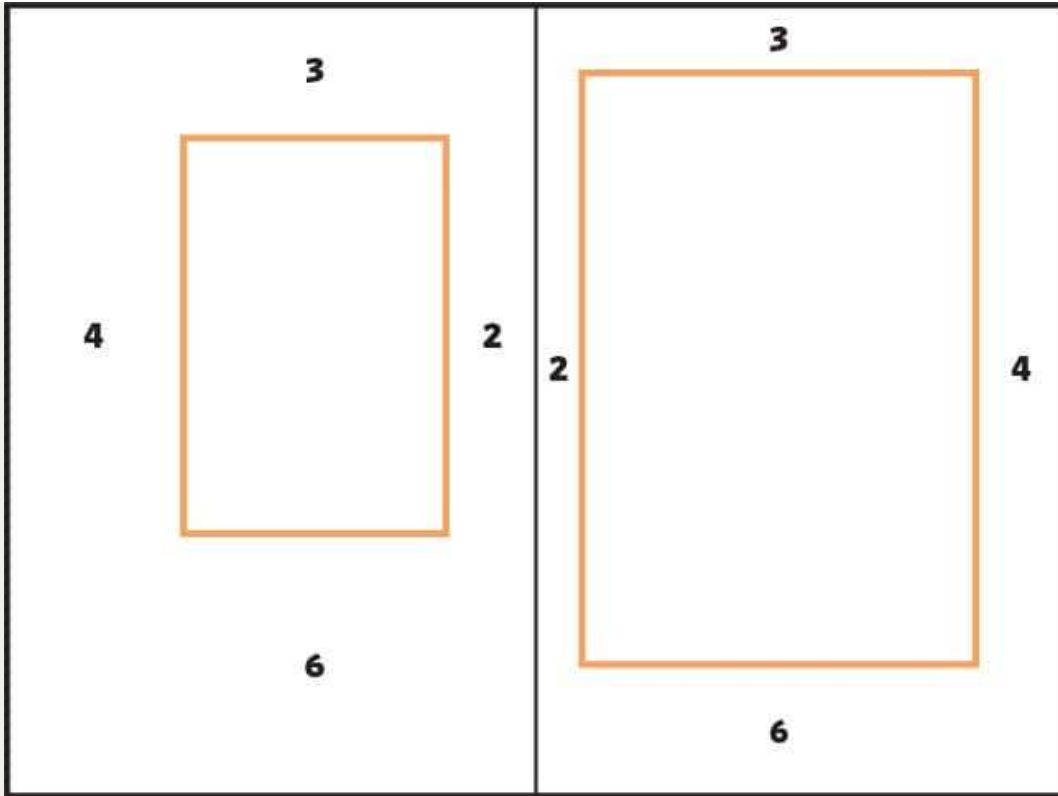

Step 4 **The Villard diagram can be used to create different sized text block areas, all of which have margins in 2:3:4:6 ratios.**

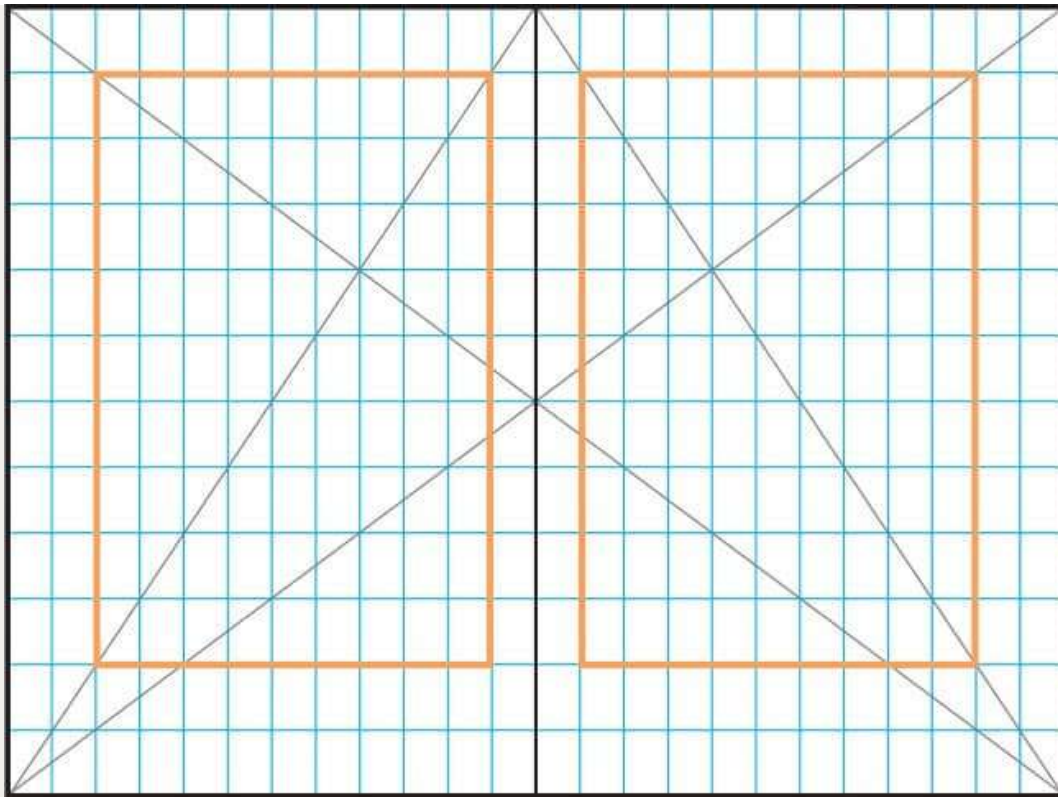

12×12 GRID, BASED ON A 1/9TH TRIANGLE

Preferred Numbers

Preferred numbers are another proportional system that provides you with a methodology to select proportional values for any compositional layout.

As with the Fibonacci Sequence, using preferred numbers ensures that there is a unified and harmonious series of spatial relationships with the resulting divisions of a compositional layout, as opposed to relying upon random or equal values. The benefit in using a system of preferred numbers, such as Renard Numbers, is that the numbers provide a methodology for dividing a compositional layout format into proportions that are visually more dynamic and harmonious than if they were simply divided into equal segments.

Renard Numbers

In 1870, engineer Charles Renard (French, 1847–1905) developed a system of preferred numbers that divides an interval from 1 to 10 into 5, 10, 20, or 40 steps. The numerical factor between these two consecutive numbers is an approximate constant, namely the 5th, 10th, 20th, or 40th root of 10 or

approximately 1.58, 1.26, 1.12, and 1.06 respectively, which is a geometric sequence.

The two page grids shown above, one symmetrical and the other asymmetrical, were both constructed using the Renard series of preferred numbers.

Renard Numbers

Symmetrical Grid

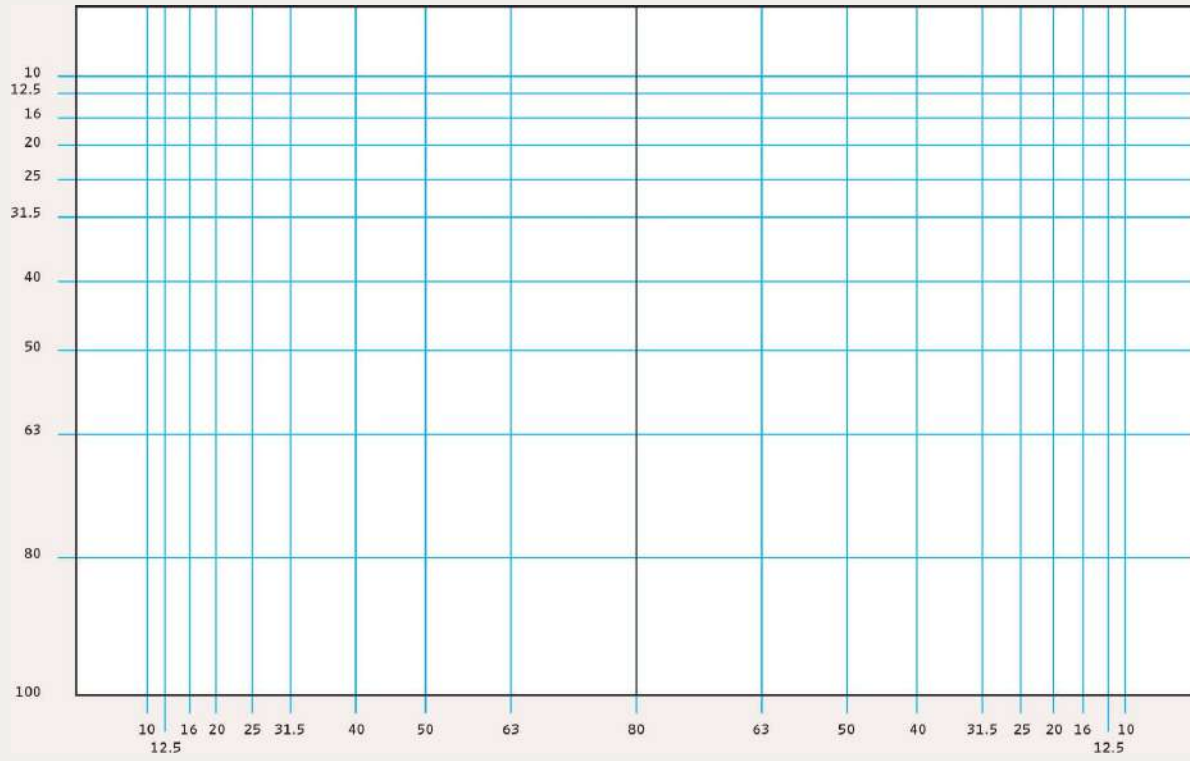

Renard Numbers

Asymmetrical Grid

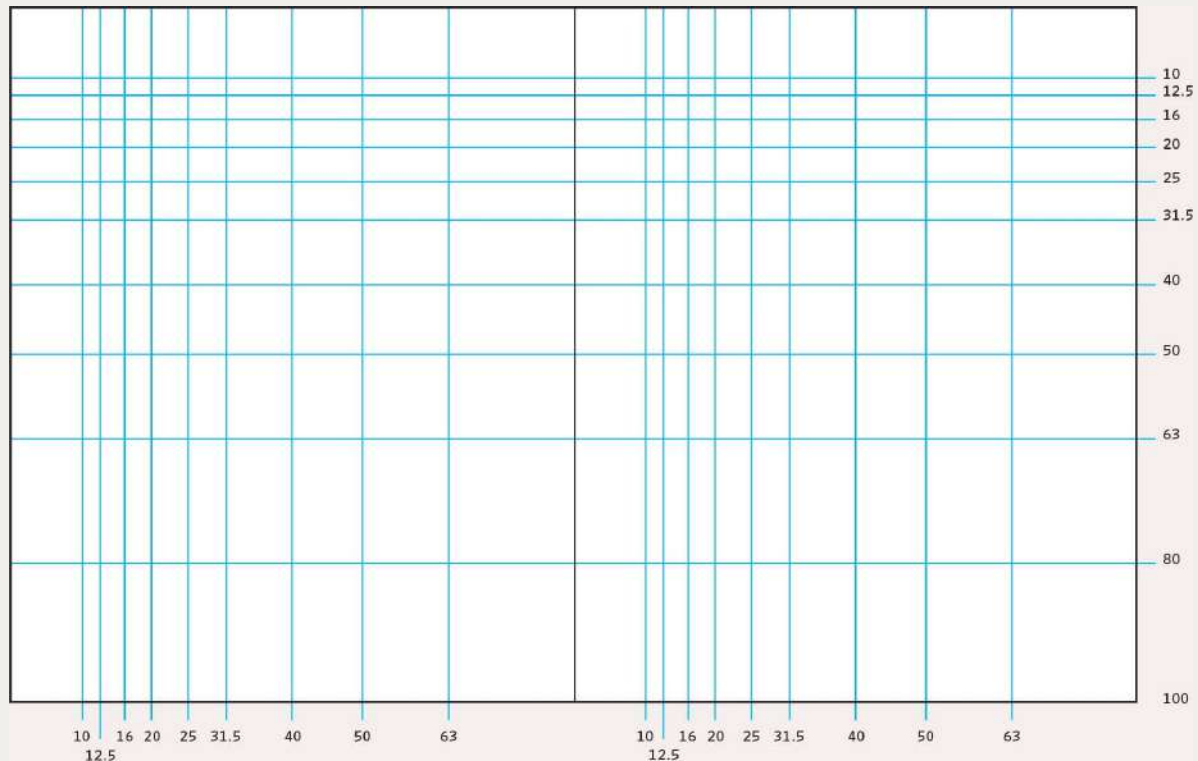

Special Numbers

Numerical values have always been an integral and valuable element in most design disciplines, including graphic design. Their function and significance is much more than solely a means for measurement. For example, the use of odd numbers in compositional layouts is the basis for asymmetry which is much more dynamic and engaging than relying upon even numbers and symmetry. Based on this premise, the number three or “the rule of thirds” is a critical consideration when creating any compositional layout.

“*Omne trium perfectum*” is a Latin phrase that means everything that comes in threes is perfect, or, every set of three is complete, a concept which helps explain why threes or triples are such a powerful visual device in graphic design and other design disciplines.

The Rule of Thirds

In the visual world, it is common knowledge that the “rule of thirds” is a powerful and effective formula for creating and organizing dynamic compositional layouts. This proportional system is based on the theory that the human eye is naturally drawn to intersection points that occur when an image is split into thirds.

The system can be applied to a compositional layout when it is divided into thirds, both vertically and horizontally, creating a compositional grid of three columns, three rows, nine modules, and four intersection focal points. Primary visual elements within a compositional layout are then positioned at the four intersection focal points to create visual tension, movement, and activity (see left).

This rudimentary proportional system was relied upon by Renaissance artists and sculptors since it has a close mathematical relationship to the golden ratio; however it is not an exact correlation. Today, this proportional system applies to print and digital applications of graphic design, as well as photography and film.

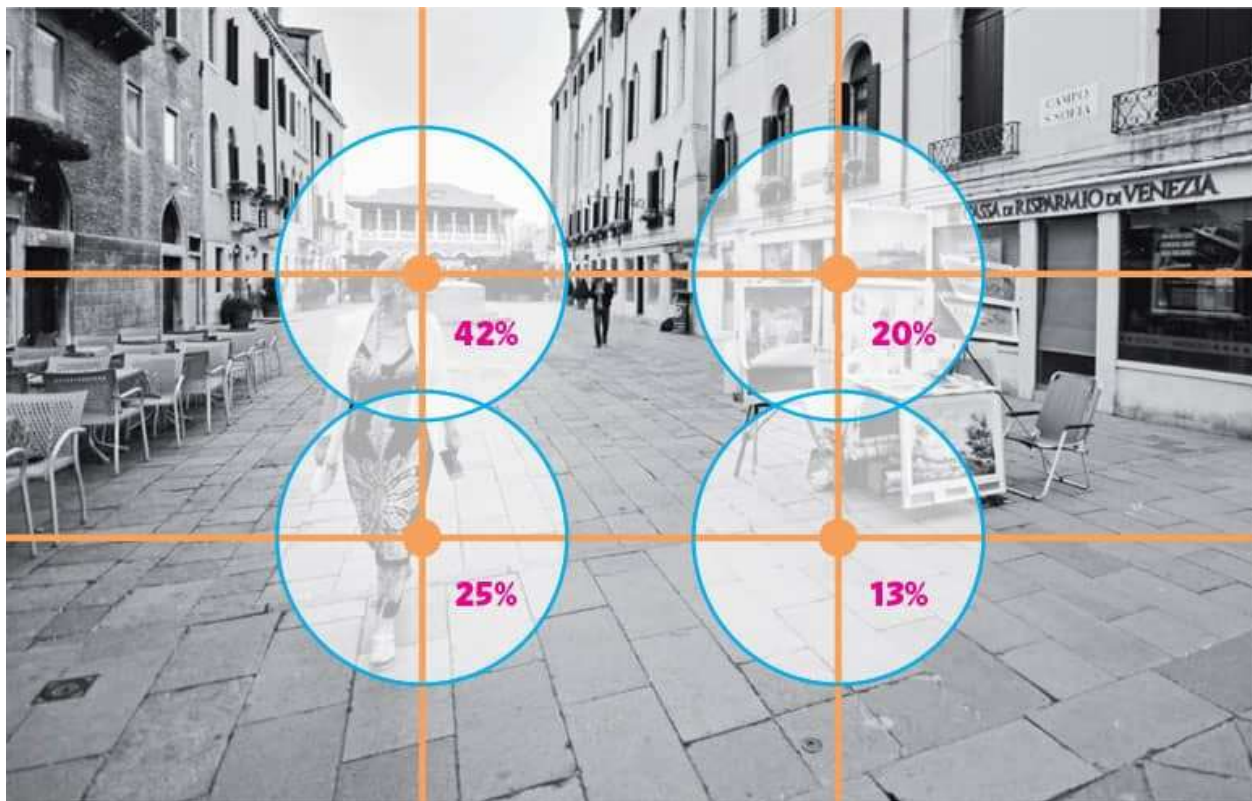

Images: ©Alphotographic, ©chrisbrignell, ©workhardphotos.

These photographs show how the rule of thirds can be used to create focal points within a compositional frame. By dividing an image into three equally sized horizontal and vertical sections, the resulting organizational grid defines optimum locations in which to place compositional elements. Whether aligning with its horizontal or vertical

lines, or with its intersection points, visual tension and interest can be achieved in any compositional layout.

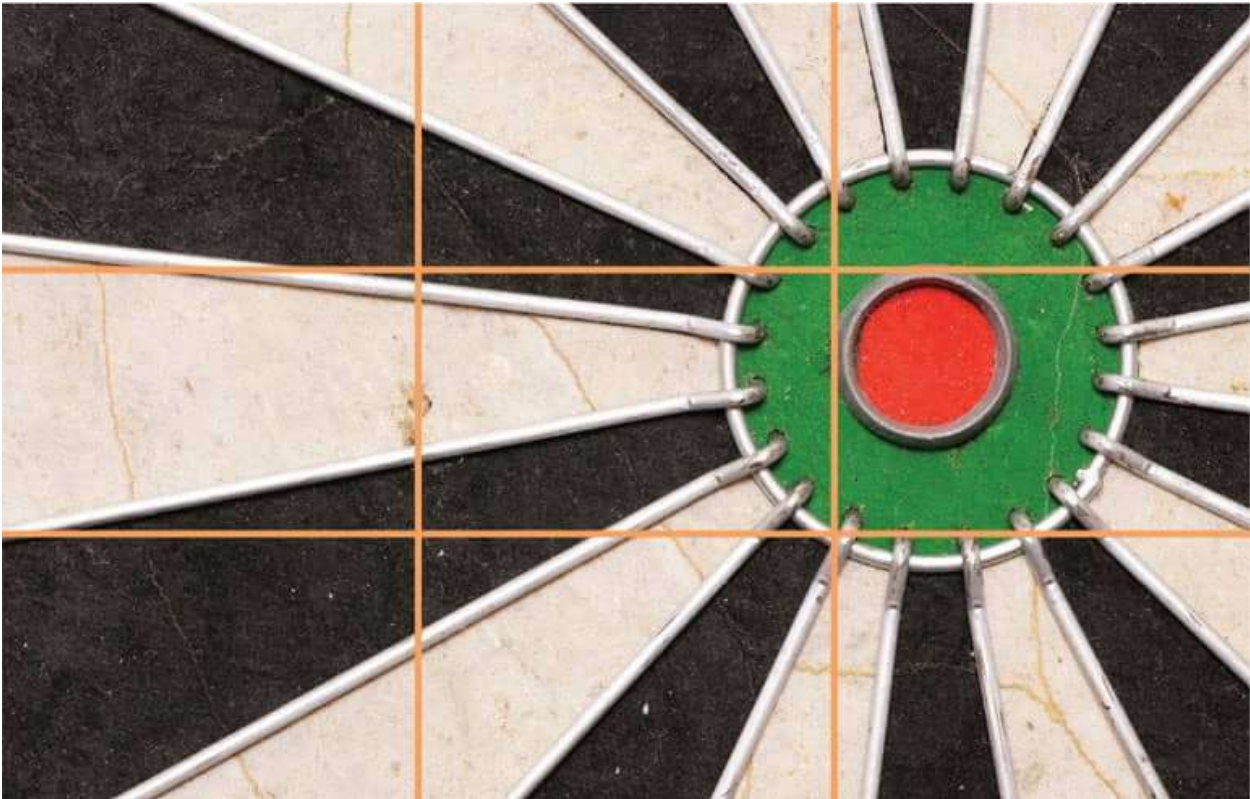



Le Modulor

In 1945, noted modernist architect Le Corbusier, also known as Charles-Edouard Jeanneret (Swiss, 1887–1965), introduced a new proportional system based on human measurements, the double unit, the Fibonacci Sequence, and the golden section called “Le Modulor.”

Le Corbusier developed this new proportional system based on the historical traditions established by Vitruvius, Leonardo da Vinci, and Leon Battista Alberti (Italian, 1404–1472), all of whom used mathematical proportions and measurements of the human figure to influence and improve the ultimate proportions and functions of their work.

Le Modulo

8×1	8×2	8×3	8×5	8×8
5×1	5×2	5×3	5×5	5×8
3×1	3×2	3×3	3×5	3×8
2×1	2×2	2×3	2×5	2×8
1×1	1×2	1×3	1×5	1×8

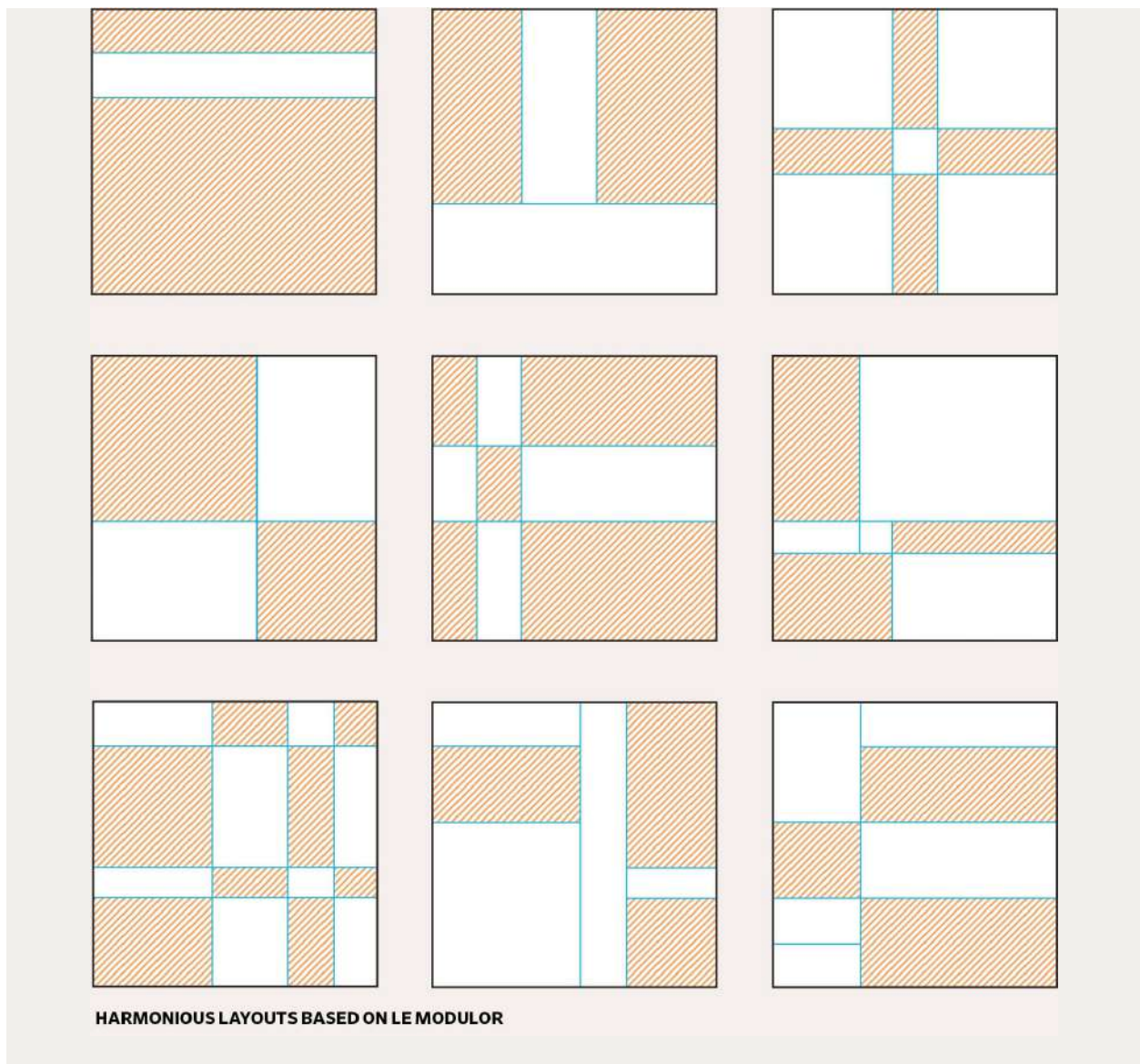

Le Corbusier's organized his new system on three main datums of human anatomy—the top of the head, the solar plexus, and the tip of the right hand (see above).

Le Corbusier ultimately described his system as a “range of harmonious measurements to suit the human scale, universally applicable to architecture and to mechanical things.” It was used as a system to plan and develop several of his buildings and was later codified into two volumes, *Le Modulor* (1948) and *Modulor 2* (1955).

While *Le Modulor* was not universally utilized when it was first introduced, it became an inspiration and primary resource for the further development of grid systems of the International Typographic Style and Modernist graphic design

movements during the latter part of the twentieth century.

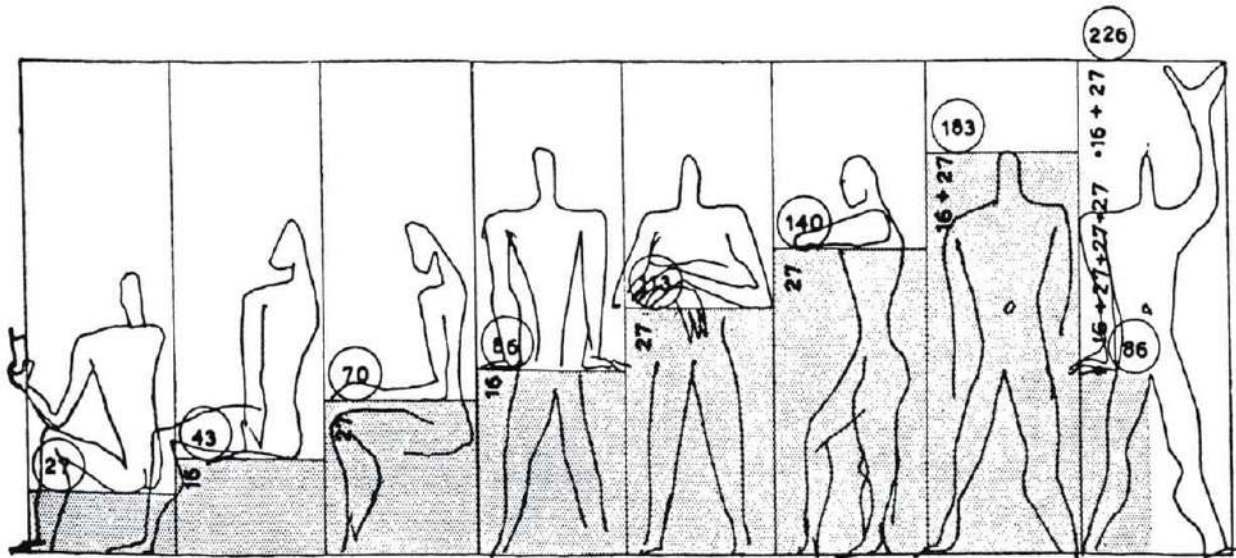

Image: ©Fondation Le Corbusier.

Le Corbusier's proportional system, Le Modulor, is based on the Golden Section, the Fibonacci Sequence, and the functional dimensions and stature of the human body.
Image: ©Fondation Le Corbusier.

ISO Standard Paper Sizes

ISO standard paper sizes, also known as ISO (International Standards Organization) metric sizes, is the most common and universal paper size system, used extensively throughout the metric-based world. This system, initially known as DIN A (Deutsche Industrie Norm) was first introduced in Germany in 1922.

Standardized paper sizes provide you with a convenient and efficient means to communicate with one another. The practical benefits of standard paper sizes have been recognized for centuries and their usage has a history that is traced back to fourteenth century Italy.

These proportional size standards are based on a rectangle that has a proportional height-to-width ratio of the square root of 2 (1:1.4142), which means that each paper size differs from the next or previous by a factor of 2 or 1/2. No matter how many times a sheet size of these proportions is halved, its proportions remain constant.

ISO paper sizes are organized in three series identified as A, B, and C; the A series is primarily used for printed matter such as business stationery and publications, the B series is primarily used for posters and data charts, and the C

series is primarily used for envelopes. Each size within each series is uniquely identified with the suffix “zero” (0), as in A0, B0, and C0. A smaller size within a series, as in A1, A2, and A3, is equal to half the area of the preceding page size. If the shorter side is doubled or the longer side halved, the resulting proportions remain the same.

ISO Standard Paper Sizes

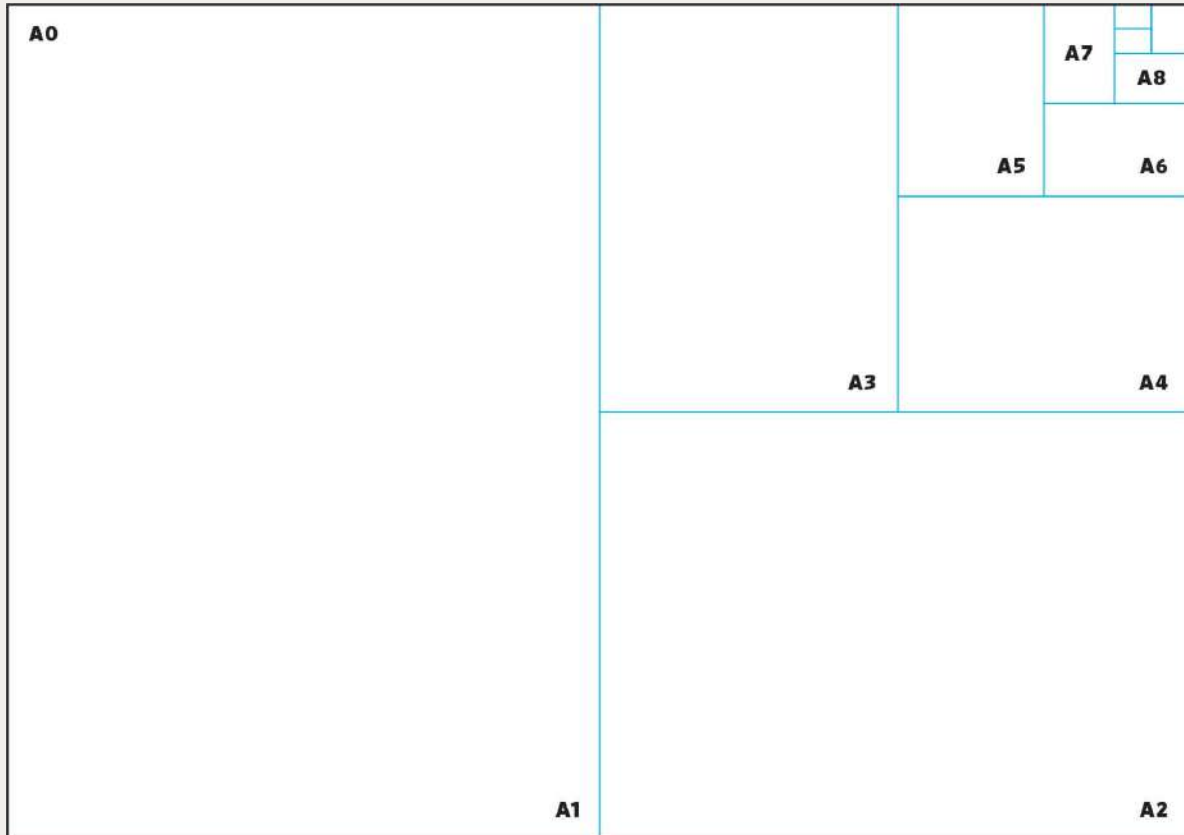

A SERIES

A0	841 × 1189 mm 33.1 × 46.8 in
A1	594 × 841 mm 23.4 × 33.1 in
A2	420 × 594 mm 16.5 × 23.4 in
A3	297 × 420 mm 11.7 × 16.5 in
A4	210 × 297 mm 8.3 × 11.7 in
A5	148 × 210 mm 5.8 × 8.3 in

A6 105 × 148 mm
4.1 × 5.8 in

A7 74 × 105 mm
2.9 × 4.1 in

A8 52 × 74 mm
2.0 × 2.9 in

A9 37 × 52 mm
1.5 × 2.0 in

A10 26 × 37 mm
1.0 × 1.5 in

B SERIES

B0 1000 × 1414 mm
39.4 × 55.7 in

B1 707 × 1000 mm
27.8 × 39.4 in

B2 500 × 707 mm
19.7 × 27.8 in

B3 353 × 500 mm
13.9 × 19.7 in

B4 250 × 353 mm
9.8 × 13.9 in

B5 176 × 250 mm
6.9 × 9.8 in

B6 125 × 176 mm
4.9 × 6.9 in

B7 88 × 125 mm
3.5 × 4.9 in

B8 62 × 88 mm
2.4 × 3.5 in

B9 44 × 62 mm
1.7 × 2.4 in

B10 31 × 44 mm
1.2 × 1.7 in

C SERIES	
C0	917 × 1297 mm 36.1 × 51.1 in
C1	648 × 917 mm 25.5 × 36.1 in
C2	458 × 648 mm 18.0 × 25.5 in
C3	324 × 458 mm 12.8 × 18.0 in
C4	229 × 324 mm 9.0 × 12.8 in
C5	162 × 229 mm 6.4 × 9.0 in
C6	114 × 162 mm 4.5 × 6.4 in
C7	81 × 114 mm 3.2 × 4.5 in
C8	57 × 81 mm 2.2 × 3.2 in
C9	40 × 57 mm 1.6 × 2.2 in
C10	28 × 40 mm 1.1 × 1.6 in

The A0 standard sheets are the same proportions, with its largest sheet size measuring 841 x 1189 mm (33.1 x 46.8 inches) with an area of one (1) square meter. Each subsequent number after the initial A series indicates half (or 50 percent) of the previous (larger) area. For example, sheet A1 measures 594 x 841 mm (23.4 x 33.1 inches) which is half of sheet A0. Sheet A2 measures 420 x 594 mm (16.5 x 23.4 inches) and is one quarter (or 25 percent) of sheet A0, and sheet A3 measures 297 x 420 mm (11.7 x 16.5 inches) and is an eighth of sheet A0. Sheet sizes larger than A0 maintain the same proportions and are identified with

a prefix numeral to the letter—2A0 identifies a sheet size that is twice as large as 0, or 1189 mm x 1682 mm (46.8 x 66.2 inches).

United States and Canadian Paper Sizes

ISO standard paper sizes are used throughout the world with the exception of United States and Canada, where paper sizes and formats are regulated by American National Standards. Common sizes based on these standards are letter (8.5 x 11 inches), legal (8.5 x 14 inches), executive (7 x 10 inches), and ledger/tabloid (11 x 17 inches).

Similar to the ISO standard paper size system, the United States system also relies upon a proportional relationship in its ratios of sizes. However, while ISO is based on a uniform aspect ratio, the United States system alternates between two ratios, namely 1.545 or 11 x 17 and 1.294 or 17 x 22, which limits the reducing and enlarging of one format to the next without having a vacant margin.

The Canadian standard, CAN 2-9.60M, was introduced in 1976 and defines six (6) P size formats that are rounded versions of the United States sizes. These sizes also lack a common height/width ratio and differ from what the majority of the world uses.

United States and Canadian Paper Sizes

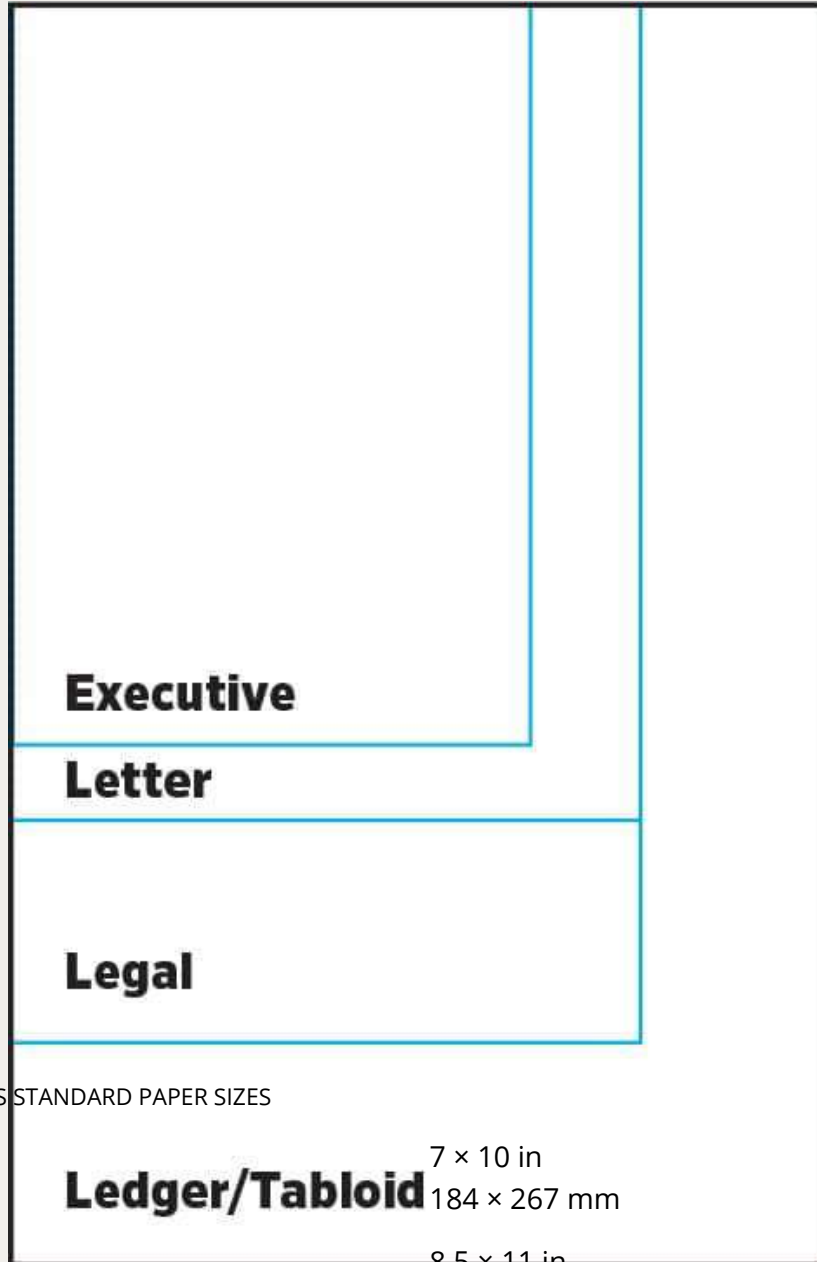

UNITED STATES STANDARD PAPER SIZES

Executive

7 × 10 in

Ledger/Tabloid

184 × 267 mm

Letter

8.5 × 11 in

216 × 279 mm

Legal

8.5 × 14 in

216 × 356 mm

Ledger/Tabloid

11 × 17 in

279 × 432 mm

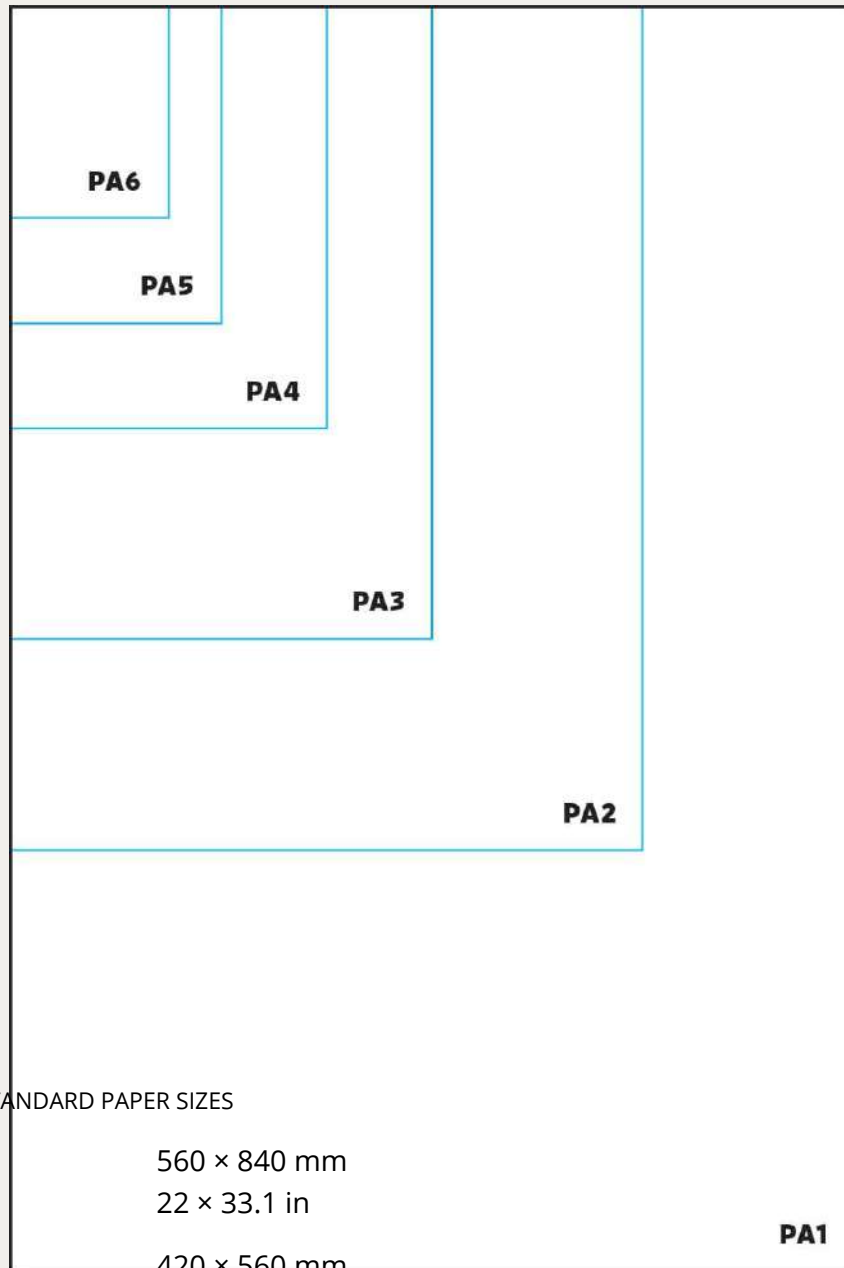

CANADIAN STANDARD PAPER SIZES

PA1 560 × 840 mm
22 × 33.1 in

PA2 420 × 560 mm
16.5 × 22.1 in

PA3 280 × 420 mm
11 × 16.5 in

PA4 210 × 280 mm
8.3 × 11 in

PA5 140 × 210 mm
5.5 × 8.3 in

105 × 140 mm

PA1

PA6

105 × 140 mm
4.1 × 5.5 in

Standard Book Sizes

Standard book sizes are measured from the head to tail of the book's spine and from edge to edge across the book's covers. The size of a book's page is determined by the sheet it is printed on, as well as the number of times that sheet size is folded before it is trimmed.

Most book sizes are defined by the number of leaves that are created from a standard sheet size for each book signature that is printed. For example, a folio book is comprised of signatures that have been folded once; a quarto book is comprised of signatures that have been folded twice to create four (4) leaves and eight (8) pages; and an octavo book is comprised of signatures that have been folded three (3) times to create eight (8) leaves and sixteen (16) pages (see right).

Scrutinize any bookshelf and you soon realize that books are available in a wide range of sizes and formats based on proportional variations.



Standard Book Sizes

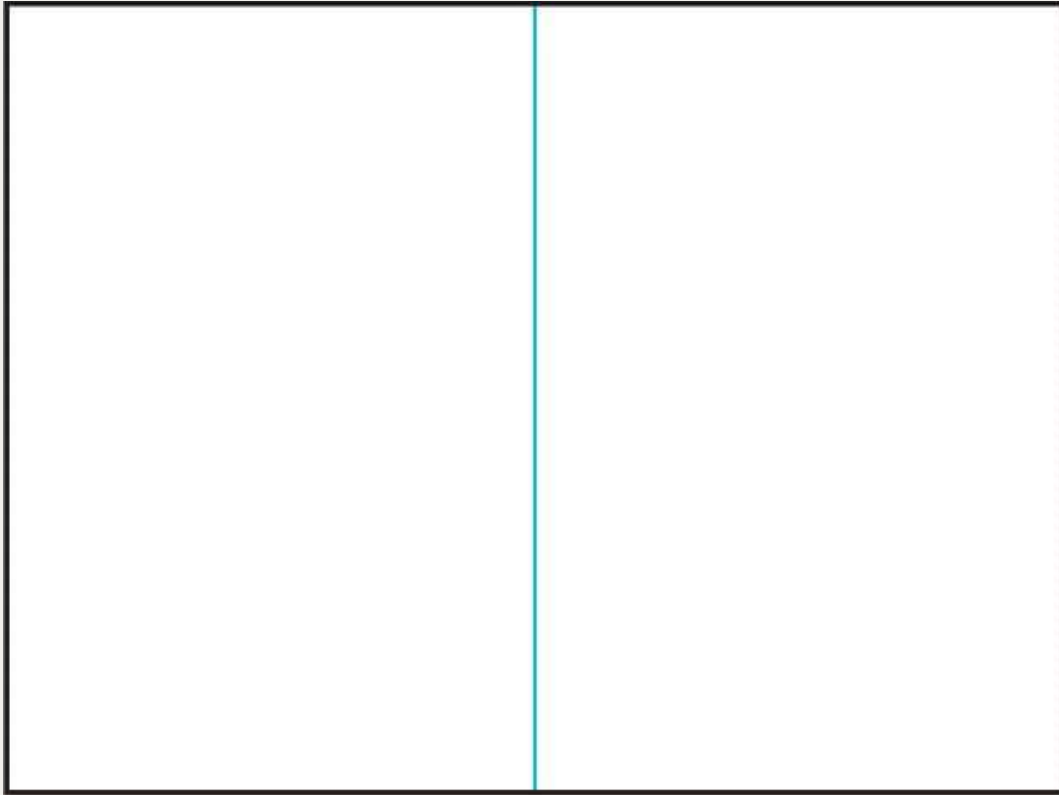

FOLIO (1 FOLD)

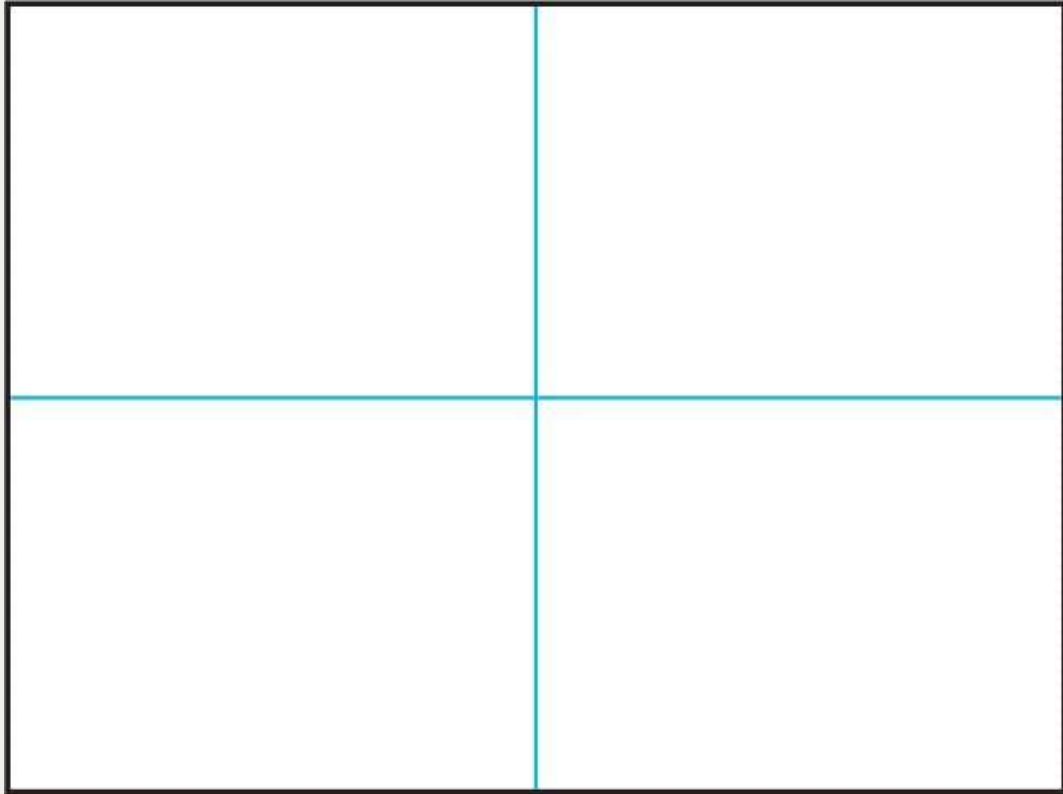

QUARTO (2 FOLDS)

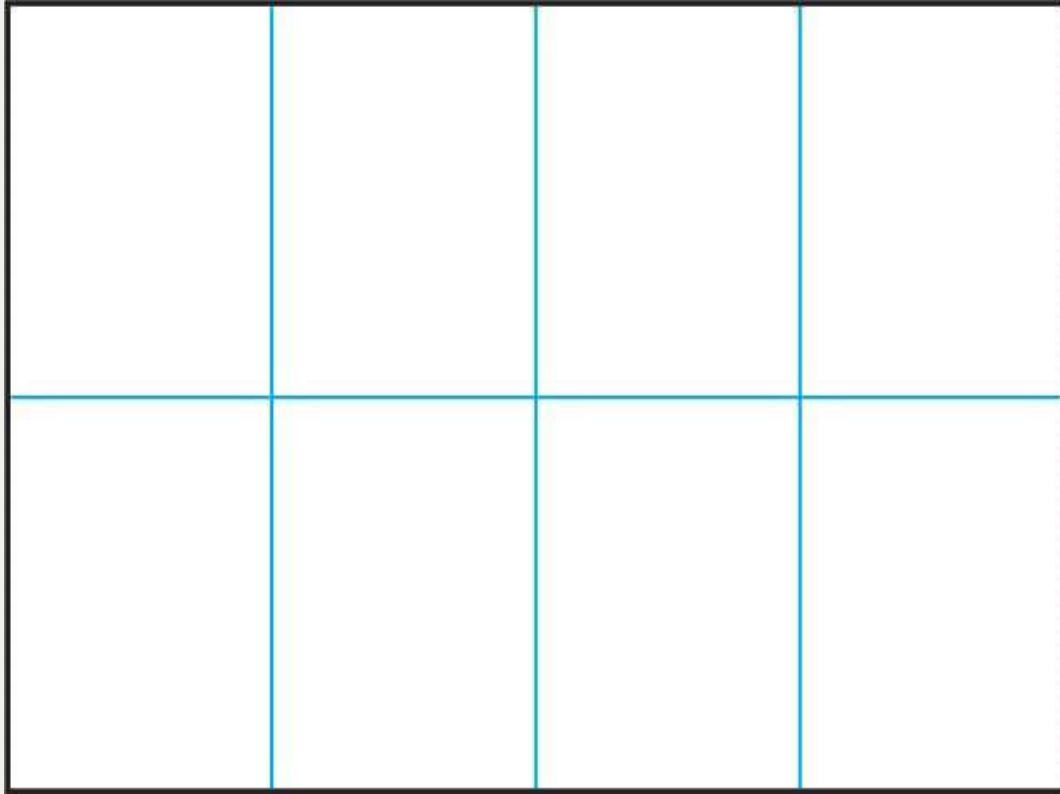

OCTAVO (3 FOLDS)

BRITISH STANDARD BOOK SIZES

	Octavo	Quarto
Pott	6.3 × 4 in 160 × 102 mm	8 × 6.3 in 203 × 160 mm
Foolscap	6.8 × 4.3 in 173 × 109 mm	8.3 × 6.8 in 211 × 173 mm
Crown	7.5 × 5 in 191 × 127 mm	10 × 7.5 in 254 × 191 mm
Large Crown	8 × 5.3 in 203 × 134 mm	10.5 × 8 in 267 × 203 mm
Large Post	8.3 × 4.3 in 213 × 109 mm	10.3 × 8.3 in 262 × 211 mm
Demy	8.8 × 5.6 in 224 × 142 mm	11.3 × 8.8 in 287 × 224 mm
Post	8 × 5 in	10 × 8 in

	203 × 127 mm	254 × 203 mm
Small Demy	8.5 × 5.6 in 216 × 142 mm	11.3 × 8.5 in 287 × 216 mm
Medium	9 × 5.8 in 229 × 147 mm	11.5 × 9 in 292 × 229 mm
Small Royal	9.3 × 6.1 in 236 × 155 mm	12.3 × 9.3 in 312 × 236 mm
Royal	10 × 6.3 in 254 × 160 mm	12.5 × 10 in 318 × 254 mm
Super Royal	10.3 × 6.8 in 262 × 173 mm	13.5 × 10.3 in 343 × 262 mm
Imperial	11 × 7.5 in 280 × 191 mm	15 × 11 in 381 × 279 mm

UNITED STATES STANDARD BOOK SIZES*

48 mo	2.5 × 4 in 65 × 100 mm
32 mo	3.5 × 5.5 in 90 × 140 mm
18	4 × 6.5 in 100 × 165 mm
16 mo	4 × 6.75 in 100 × 170 mm
12 mo	5 × 7.375 in 125 × 190 mm
Crown Octavo	5.375 × 8 in 135 × 200 mm
Octavo	6 × 9 in 150 × 230 mm
Medium Octavo	6.5 × 9.25 in 165 × 235 mm
Royal Octavo	6.5 × 10 in 165 × 250 mm

Super Octavo

7 × 11 in
180 × 280 mm

Imperial Octavo

8.25 × 11.5 in
210 × 290 mm

Quarto

9.5 × 12 in
240 × 305 mm

Folio

12 × 19 in
305 × 480 mm

*Source: American Library Association.

Test your Knowledge

1. What are the primary distinctions of an absolute measurement system and a relative measurement system?
2. What are the standard fixed values of units of the American–British point system?
3. What are the standard fixed values of units of the metric system?
4. What are the two (2) rational values of relative type measurement in typography?
5. What are three (3) proportional systems that a graphic designer can use to create varied spatial relationships in a compositional layout?
6. What is the name of the figurative drawing that is one of the most universal images representing the visual theory of a proportional system created by Leonardo da Vinci?
7. What is the numerical ratio of the golden section?
8. Construct a Van de Graaf Canon.
9. Identify a numerical series that is based on the Fibonacci sequence.
10. Construct a dynamic rectangle and identify its aspect ratio.
11. What is the name of the proportional system developed by noted modernist architect Le Corbusier?
12. What is the height-to-width ratio of ISO standard paper sizes?

13. What absolute measurement system is the ISO standard paper size system based on?

14. Construct a Villard diagram.

For answers to Test your Knowledge, see [here](#).



Section 2

Anatomy of a Grid

To better understand, appreciate, and recognize the multitude of anatomical elements applicable to any grid system (as further defined in *Section 3*), as well as the similarities and differences between them, a wellrounded and informed graphic designer needs to be familiar with all of their forms, structures, and nuances. Each grid system, from the simple framework of a manuscript grid (see [here](#)) to the more complex one in a hierarchical grid (see [here](#)), has a distinct and unique appearance, as well as characteristics and features that ultimately produce a compositional layout based on how you utilize and compose visual and narrative content.

Each grid system is composed of a set of alignment-based elements that function as guides for organizing and displaying visual elements in a compositional layout (see [here](#) to [here](#)). These anatomical elements are common to each grid system, whether it is simple or complex in structure, and can be combined or not, to meet the needs of your visual and narrative content needs and objectives.

A well-planned grid system can provide you with an endless number of compositional opportunities. It is also your responsibility to consider new ways of approaching grid systems when considering one for a specific application. Every design problem is different and therefore requires a grid system that meets its specific needs. This essential understanding will ultimately affect your visual judgements and facilitate better and more meaningful decisions in making selections and applications with any grid system. The main anatomical elements of a grid system are margins, columns, modules, spatial zones, flowlines, markers, gutters, alleys, and fields.

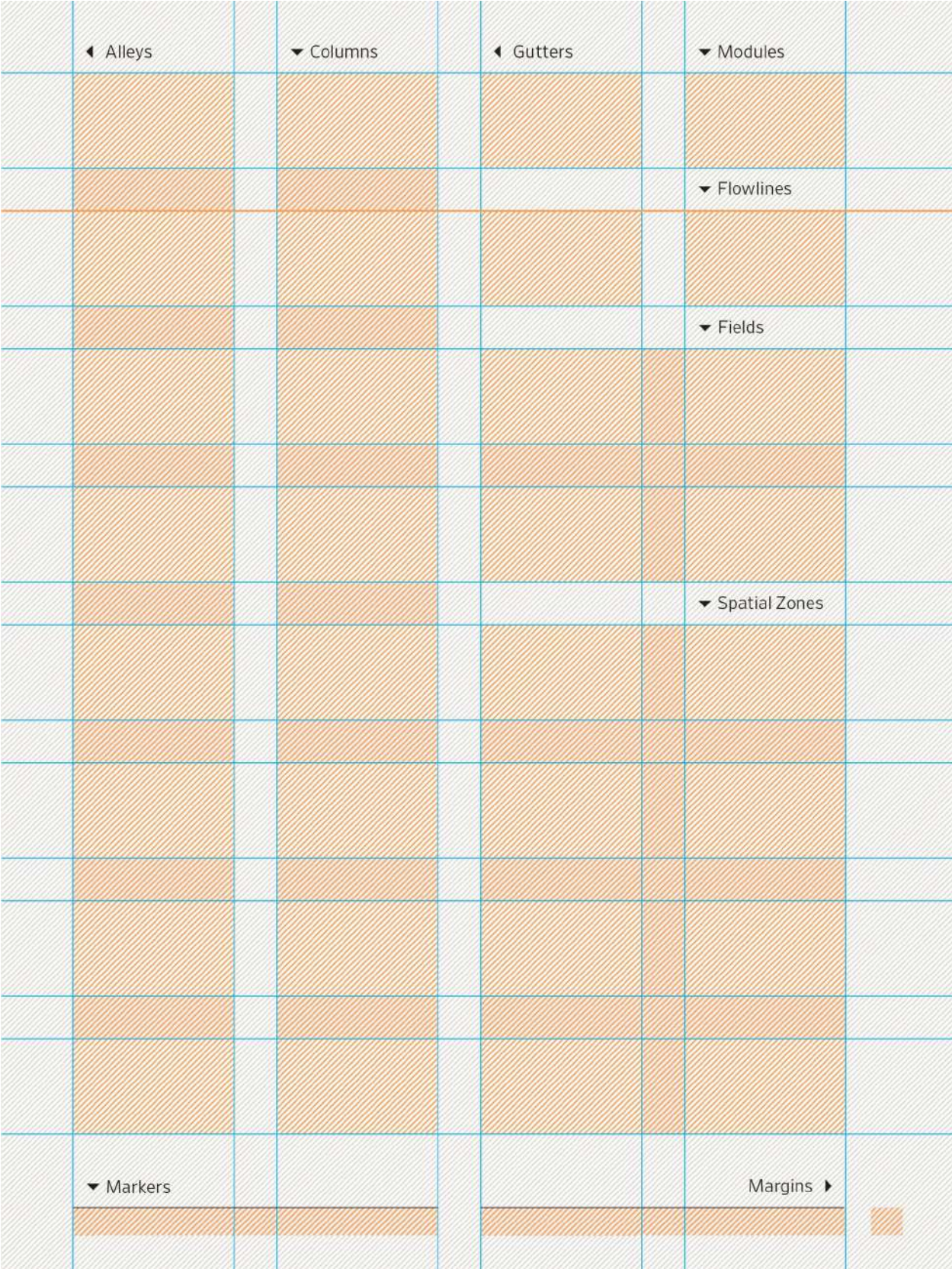

their primary functions is to effectively frame the visual and narrative content of a layout so that a reader can effectively engage with this content and ultimately its message. Your decision to either establish equal symmetrical margins or unequal asymmetrical margins will either minimize or maximize the presence of visual and narrative content in any compositional layout. Equal margins create a static compositional layout while unequal margins allow a compositional layout to appear more dynamic and active. Margins that are wider in proportion than the page's column gutters create an inward focus for a reader, while the visual tension is reduced when a margin is close to an edge of a page.

You also need to consider the proportions and dimensions of a compositional layout's inner margins in a two-page spread so that visual and narrative content does not disappear or become difficult for a reader to engage with, due to it getting lost in the gutter and spine of the book or publication. From a practical point of view, the width of a page spread's outer margins should also be substantial enough that they allow a reader to handle a book or publication with ease, as well as leaving enough space for a reader's thumbs.

In a conventional grid system, such as a manuscript grid (see [here](#)), a considerable and obvious set of margins can create visual interest in an otherwise standard compositional layout. Variations in the size of a margin also provides any compositional layout with limited or ample white space for you to utilize, if needed.

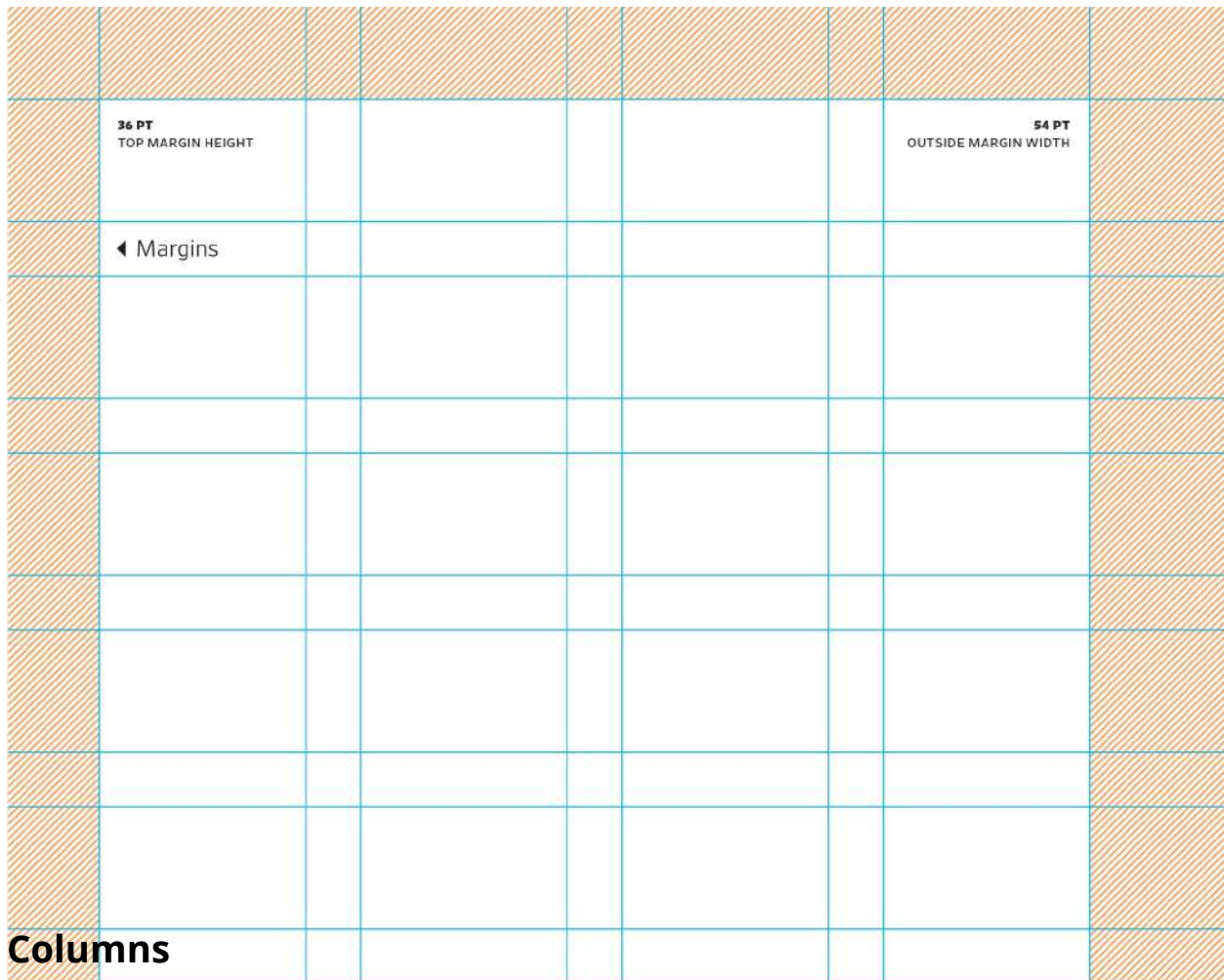

Columns

Columns are vertical alignments of type that create vertical divisions between the live area of a compositional layout's margins. There can be any number of columns in a grid system; sometimes they are all the same width or are different widths corresponding to specific types of informational content.

The determination of column width and line length are important considerations when your objective is optimum readability and legibility of text type. Type size, line length, and leading are all integral characteristics of a column that need to be carefully analyzed when determining a column's final width and measure. You also need to evaluate a given type size in relationship to a column width and the number of characters it can accommodate, so that it is the optimum quantity for a reader's eye comfort and ease. A character count of sixty (60) to seventy-two (72) characters (including word spaces) per text line for any given line length is recommended for optimum readability.

This criterion changes depending upon typeface selection and type size. If a column width is too narrow for a given type size, excessive hyphenation of words will occur. If it is too wide for a given type size, a reader will tire quickly

words will occur in the text for a given type size, a reader will be quick since they will have difficulty finding the beginning of each new sequential line.

A text column's optimum width and measure provides an even and comfortable interaction for a reader with not only continuous narrative text within a compositional layout, but with all of its visual elements.

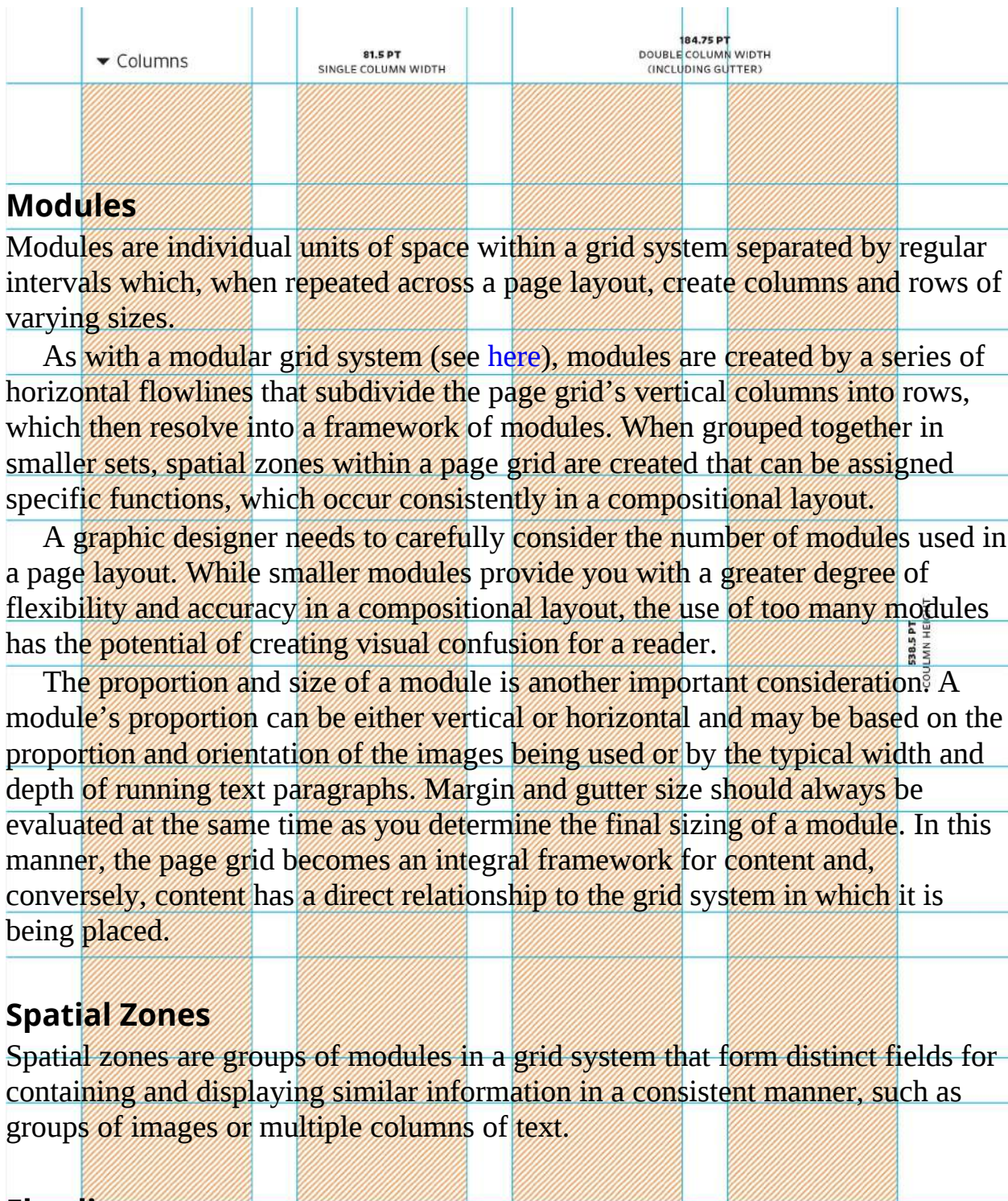

Modules

Modules are individual units of space within a grid system separated by regular intervals which, when repeated across a page layout, create columns and rows of varying sizes.

As with a modular grid system (see [here](#)), modules are created by a series of horizontal flowlines that subdivide the page grid's vertical columns into rows, which then resolve into a framework of modules. When grouped together in smaller sets, spatial zones within a page grid are created that can be assigned specific functions, which occur consistently in a compositional layout.

A graphic designer needs to carefully consider the number of modules used in a page layout. While smaller modules provide you with a greater degree of flexibility and accuracy in a compositional layout, the use of too many modules has the potential of creating visual confusion for a reader.

The proportion and size of a module is another important consideration. A module's proportion can be either vertical or horizontal and may be based on the proportion and orientation of the images being used or by the typical width and depth of running text paragraphs. Margin and gutter size should always be evaluated at the same time as you determine the final sizing of a module. In this manner, the page grid becomes an integral framework for content and, conversely, content has a direct relationship to the grid system in which it is being placed.

Spatial Zones

Spatial zones are groups of modules in a grid system that form distinct fields for containing and displaying similar information in a consistent manner, such as groups of images or multiple columns of text.

Flowlines

Flowlines, also called hanglines, are horizontal alignments in a grid system that organize visual and narrative content into defined areas, assist in guiding a reader's eyes across a compositional layout, and imply additional start and stop points for type or images on a page layout. A page grid may contain one or more

flowlines located at regular intervals organizing a page from its top to bottom edge in a repeated proportion with an array of rows that intersect the page grid's columns.

Flowlines are invisible datums or guidelines, not actual lines, which assist in the organization of visual elements and negative space, as well as assisting a reader's navigation across a page layout or spread. For example, in a columnar grid system (see [here](#)), flowlines can function as a secondary structure that you can rely upon to establish unusual breaks in text or image placement. They can define a consistent location on a page for running headers or page numbers, as well as delineate areas on a page for either images or various types of text-driven data such as timelines, subarticles, and pull-quotes.

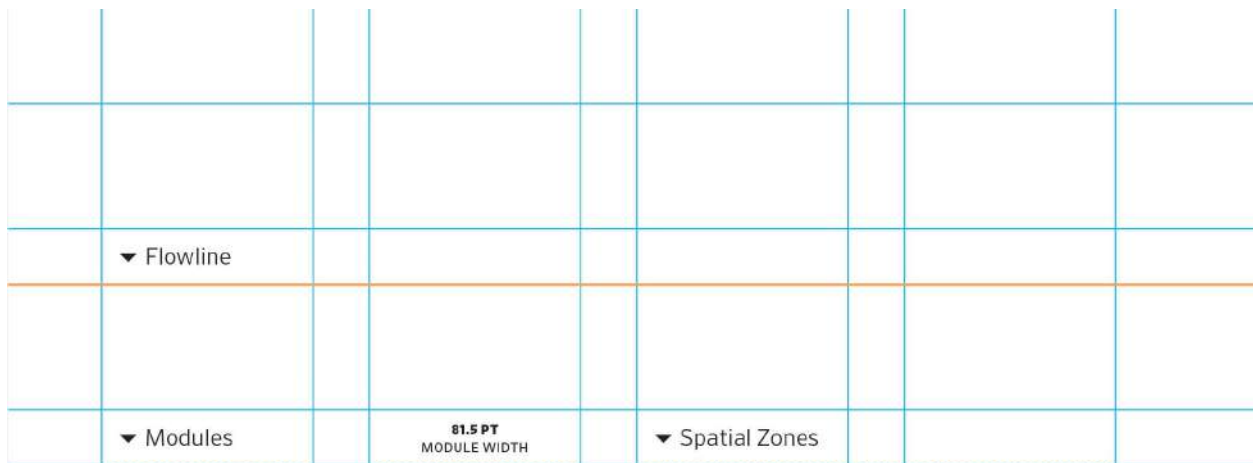

Markers

Markers are placement indicators in a grid system for supporting page information such as running headers or footers, folios or page numbers, or any other repeating element that occupies a consistent location on a page layout or spread. Markers are valuable navigational tools that assist a reader in effectively engaging with detailed visual and narrative content in a book or publication.

Gutters and Alleys

A gutter is traditionally considered an inactive space on a page grid needed either as an internal edge for binding or to separate columns of running text. In addition to providing a visual separation between columns, the width and proportion of a gutter can have a dramatic impact on the overall appearance of a compositional layout, as well as the readability of its visual and narrative content.

A central gutter, or alley, is the central margin of a grid where two pages meet at the spine. Both of these terms are also used to identify the vertical space located between columns of type, as well as the fore-edge of a page.

While a gutter is traditionally used as a physical separation between pages or page elements, it can also function as a key visual element in a compositional layout. For example, minimizing or maximizing the width of a gutter in relation to adjacent visual elements in a compositional layout can either create a more obvious balance between elements or establish more visual tension between them. Gutters can also be used to bring more focus and attention to visual and narrative content in compositional layout, create a respite for the reader, and function as an area for displaying secondary, repetitive information such as running headers, footers, and folios or page numbers.

running headers, footers, and runs of page numbers.

While a central gutter is traditionally used to separate one page from another, that separation can be minimized or eliminated by running images across a central gutter. This unconventional and effective use of a central gutter can add more visual impact, variation in scale, and change in pacing, to any compositional layout sequence. However, running text across a central gutter can be more problematic, particularly at smaller type sizes.

Fields

Organizing a page grid into an array of fields (and modules) provides you with a wider range of active and dynamic compositional layouts while still maintaining the basic structure and elements of a grid system. A harmonious and dynamic compositional layout is composed of a combination of continuous text-filled columns and image-activated fields (or modules).

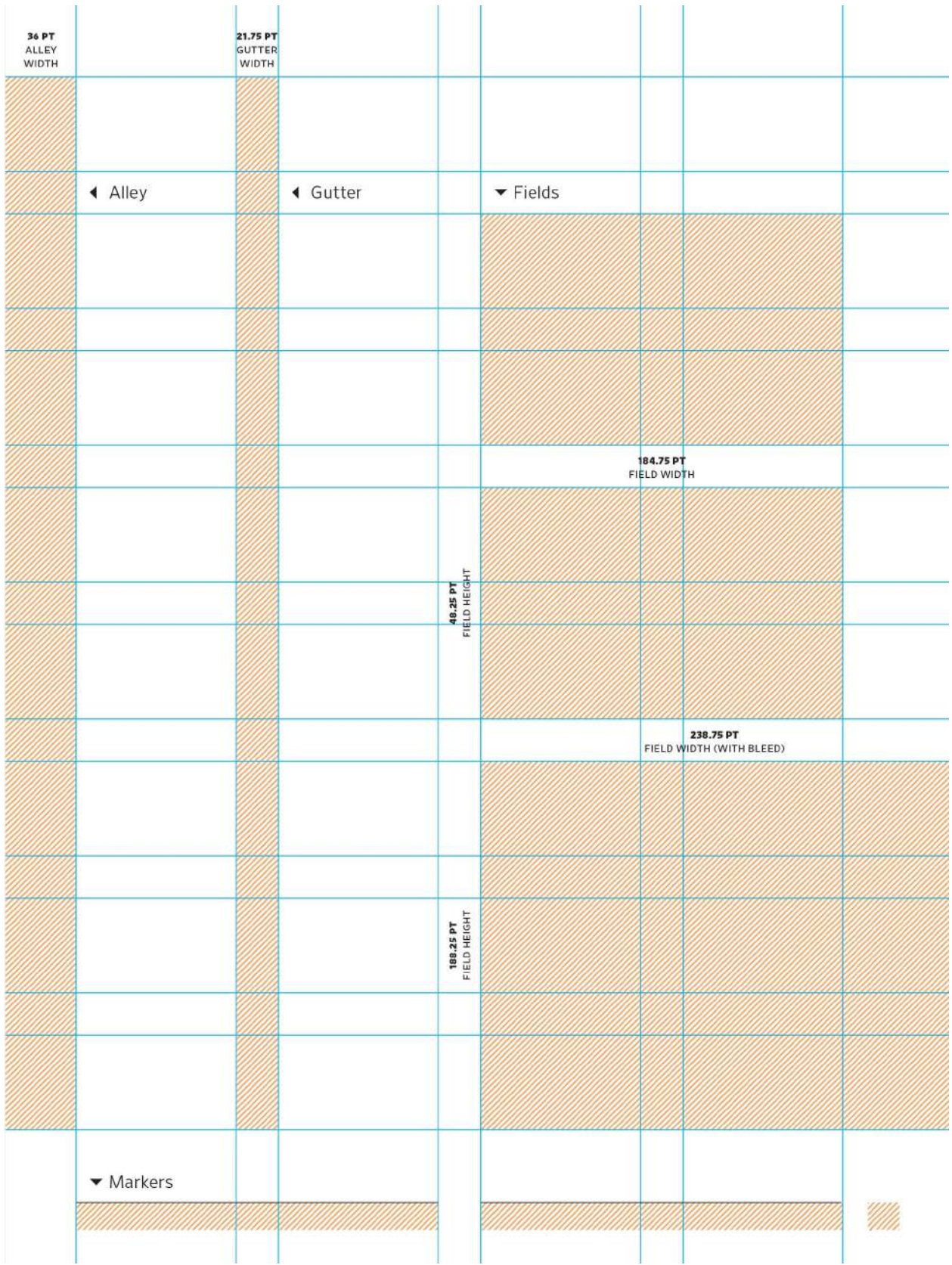

Terminology

The terminology of layout is an essential reference tool for you to understand and be familiar with since it provides a universal language to describe the various parts of any compositional layout, as well as the ability to analyze and compare their individual elements and characteristics.

A graphic designer's familiarity with these terms will also provide you with a greater understanding and sensitivity to the visual harmony and complexity of any compositional layout. To better understand, appreciate, and recognize the multitude of anatomical terms applicable to layout, as well as the similarities and differences between various layouts, a wellrounded and effective graphic designer needs to be familiar with layout fundamentals, grid systems, grid anatomy, compositional principles, and layout characteristics.

This essential understanding will ultimately influence your visual judgements, as well as facilitate better and more meaningful decisions in developing and designing compositional layouts that possess meaning and communicative messages.

Absolute Measurement

An absolute measurement system, such as the American–British Point System and the Metric System, is always based on a standard, fixed value of units—picas and points, and millimeters and centimeters respectively.

Actual Space

Actual space is the area that a visual composition physically occupies.

Alignment

The organization and positioning of visual elements in a compositional layout, such as lines of continuous text, in relation to a fixed margin or axis. Alignment options are flush (ranged), justified, or centered.

Flush left is where all visual elements start at the same left-hand vertical axis or margin (also referred to as left-justified or ragged right); flush right is where all visual elements end at the same right-hand vertical axis or margin (also referred to as right-justified or ragged left); justified is where alignment occurs on both left and right margins; and centered is where all visual elements have the same central vertical axis no matter their size.

Alley

see Gutter.

Ambiguous Figure-ground

An ambiguous figure-ground is created when the relationship between a composition's figure (or object) and ground (or space) is undetectable and disorienting, yet fully comprehensible. With this type of figure-ground, a pair of objects share the same edge or profile. A classic example of an ambiguous figure-ground is Rubin's vase, developed by psychologist Edgar Rubin (Danish, 1886–1951). In this image, the black positive space forms two profiles of a human face that appear to be ready to kiss, and the inverse negative space forms a vase. Visually, a reader's concentration on either the black or white makes the illusion alternate between the faces and the vase.

American–British Point System

The American–British Point System is an absolute measurement system based on standard fixed values of units of the point and the pica measuring 0.01383 and 0.166 inches, respectively. There are twelve (12) points in one pica and six (6) picas, or seventy-two (72) points, in one inch.

Asymmetrical Grid

A grid system in which the recto and verso pages of a compositional layout are the same and typically introduces a bias towards one page or the other (usually the left), providing an asymmetrical, or imbalanced, visual appearance to the page spread.

Asymmetry

Asymmetry occurs when visual elements are arranged deliberately unequally in a compositional layout, causing them to appear random and dynamic, to lack balance, and to appear visually off-kilter. Also called *dynamic balance*.

A Series Paper Sizes

An ISO metric paper size based on the square root of two aspect ratios. The A0 sheet size is 841 mm x 1189 mm (33.1 inches x 46.8 inches), and is one square meter in area. Each smaller size (A1, A2, A3, A4, etc.) thereafter differs from the next by a factor of 2 or 1/2.

Atmospheric Perspective

Atmospheric perspective is a visual effect that relies on the use of elements such as color, tone, and contrast to create the illusion of space and spatial relationships in a two-dimensional compositional layout.

Axonometric

An axonometric projection is a parallel projection of a form viewed from a skewed direction, in order to reveal more than one of its sides in the same picture plane. Also called *plan oblique*.

Back-Edge

A back-edge or inner margin is a vertical margin located at the back edge of the page that is closest to the spine or center fold of the page.

Back Matter

Supportive material traditionally located at the back of a book or publication that is not part of the main text and can include items such as appendices, notes, bibliography, glossary, and index. Also called *end matter*.

Balance

Balance refers to the different levels of harmony or discord established between the visual elements of a compositional layout.

Baseline

An imaginary line on which the base of letterforms sit or align.

Baseline Grid

A baseline grid is an essential element to any grid system and is composed of a series of equally spaced, horizontal baselines for the placement of running text, largescale type, and related visual elements. It is typically developed from a specific type size and leading.

Bilateral Symmetry

see Symmetry.

Bleed

The printed area that extends past the point where a page will be trimmed, allowing visual elements, such as images and color, to extend to the edge of the trimmed page.

Blind Folio

A blind folio is a page number that is counted in the numbering sequence of a book or publication but is not visible to a reader.

Block Grid

see Manuscript Grid.

Bottom Margin

see Foot Margin.

B – F

B Series Paper Sizes

An ISO metric paper size based on the square root of two aspect ratios. The B0 sheet size is 1000 mm x 1414 mm (39.4 inches x 55.7 inches), and is one square meter in area. Each smaller size (B1, B2, B3, B4, etc.) differs from the next by a factor of 2 or 1/2.

Caption

A caption is detailed, narrative text describing an illustration, photographic image, or another piece of artwork or graphic displayed in a compositional layout.

Centered Alignment

see Alignment.

Centimeter

A standard unit of length measurement in the metric system; one inch equals 2.54 centimeters.

Chiaroscuro

A technical term for achieving strong contrasts of light to create a sense of volume in modeling threedimensional objects.

Closure

A Gestalt principle of visual perception in which the human brain possesses the innate ability to perceive incomplete objects as complete.

Collage

Collage is the process and result of creating an assemblage of textures, found materials, images, newspapers and other visual elements; derived from "coller," French for "to glue."

Color

A visual property of an object that depends on a combination of reflected and absorbed light from the spectrum, as well as inherent hues found in light and pigment.

Column

A column is a vertical alignment of type that creates vertical divisions between the live area of a compositional layout's margins.

Column Gutter

see Gutter.

Column Width

see Measure.

Compound Grid

A compound grid is created by the integration of two or more multiple-column grid

systems into one organized, cohesive structure.

Consistency

Describes a considered selection of visual elements used in a compositional layout that possess similar attributes and characteristics.

Contrast

The result of placing visual elements in a compositional layout in a manner that creates an immediate and obvious difference between them.

Crown

A British standard book size measuring 246 mm x 189 mm (Quarto: 9.5 inches x 7.5 inches) and 186 mm x 123 mm (Octavo: 7.5 inches x 5 inches).

C Series Paper Sizes

An ISO metric paper size traditionally used for envelopes. The area of the C series is based on the geometric mean of the areas of the A and B series sheets of the same number. For example, the size of the C4 sheet is the geometric mean of the areas of an A4 sheet and a B4 sheet. The C0 sheet size is 917 mm x 1297 mm (36.1 inches x 51 inches).

Demy

A British standard book size measuring 276 mm x 219 mm (Quarto: 11 inches x 8.5 inches) and 216 mm x 138 mm (Octavo: 8.5 inches x 5.5 inches).

Didot

A historic European typographic unit of measurement equal to 0.0148 inches (0.0376 cm).

Direction

Our eyes can be directed to a specific location in a compositional layout based on its arrangement and composition of design elements. If elements are oriented in a specific direction, our eyes will also be led in that same direction.

Divine Proportion

see Golden Section.

Double Square

see Dynamic Rectangle.

Drop Line

see Hang Line.

Dynamic Balance

Dynamic Balance

see **Asymmetry**.

Dynamic Rectangle

A dynamic rectangle is a right-angled, four-sided rectangle in which the aspect ratio (height divided by width) of the rectangle is a distinguished value in dynamic symmetry, such as the golden section (1:1.618), a 2:3 rectangle, a double square (1:2), or a root rectangle (1:Φ, 1:2, 1:3, 1:5, etc.).

Em

A common square unit of measurement in typography equal to the size of a typeface's point size—traditionally, the width of the font's widest letter, invariably the uppercase M.

Em Dash

A dash equal to the length of one em in width. Used to indicate missing material or a break in a sentence.

Emphasis

Emphasis is a fundamental design principle that makes a specific visual element in a compositional layout stand out or draw attention to a reader's eye. Emphasis can be achieved in a compositional layout by locating visual elements on a page in locations where the eye is naturally drawn, or by using other design principles such as contrast, repetition, or movement to draw visual attention to it.

Em Space

A spatial unit of measurement in typography equal to the size of a typeface's point size. Traditionally, the width of the font's widest letter, invariably the uppercase M.

En

A common unit of measurement in typography equal to half the width of an em or em space.

En Dash

A dash equal to the length of one en in width. Used to indicate a range of values, for example show [here](#) to [here](#).

End Matter

see **Back Matter**.

En Space

A spatial unit of measurement in typography equal to half the size of a typeface's point size. Traditionally, the width of the font's widest letter, invariably the uppercase M.

Executive

An ANSI (American National Standards Institute) standard paper size measuring 7 x 10 inches.

Fibonacci Numbers

see Fibonacci Sequence.

Fibonacci Sequence

The Fibonacci Sequence is a series of numbers in which each number is the sum of the preceding two numbers, beginning with 0, 1, 1, 2, 3, 5, 8, 13, 21, 34, 55, 89, 144, 233, 377, and so on. This number series has a direct relationship to the golden section or the 8:13 proportional ratio. Also called *Fibonacci numbers* and *rational spacing*.

Field

see Spatial Zone.

Figure

The shape, form, or foreground area of a compositional layout. Also see *figure-ground*.

F - I

Figure-ground

Figure-ground is the perception of visual elements as either an object of focus (or figure) appearing in the foreground of a compositional layout, and the perceptual background field (or ground) of a compositional layout.

Flow

A term used to describe visual movement of a page layout, either between its compositional elements or from one page to another, and is perceived as organic and natural in its character and rhythm.

Flowline

A flowline is a horizontal alignment in a page grid that organizes visual and narrative content into defined areas, assists in guiding a reader's eyes across a compositional layout, and is used to imply additional start and stop points for type or images on the page.

Flush Left

see Alignment.

Flush Right

see Alignment.

Focal Point

A focal point is where a graphic designer wants to draw a reader's eye in a compositional layout.

Folio (Book Format)

Folio is the technical term describing a book or pamphlet format produced by printing two (2) text pages on each side of one sheet of paper and folding the paper once to form a signature containing two (2) leaves or four (4) pages called folios. From the Latin word meaning "folium" or "leaf." Also called *half sheet*.

Folio (Page Layout)

A folio is the name of either a page number, publication name, and date consistently located in the margin or corner of a page or a page leaf in a book or publication.

Footer

A footer is a separate area located at the bottom margin directly below the main text area of a compositional layout that traditionally contains a folio or page number, and sometimes book or chapter title and author's name.

Foot Margin

The space located at the bottom of the page. Also called *bottom margin*.

Fore-Edge

A fore-edge is the outside edge or margin of a book page or the edge or margin opposite the spine of a book or publication.

Form

Form refers to the different shapes or structures of visual elements in a compositional layout.

Format

A format is the live area in which a compositional layout sits. A page is the format in a book or publication, whereas a browser window is the format for a website.

Formal Balance

see Symmetry.

Front Matter

Supportive material traditionally located at the front of a book or publication that is not part of the main text and can include items such as a title page, half-title page, copyright, and table of contents.

Golden Mean
see Golden Section.

Golden Number
see Golden Section.

Golden Proportion
see Golden Section.

Golden Ratio
see Golden Section.

Golden Rectangle
See Golden Section.

Golden Section
A proportional system that produces harmonious spatial relationships and is based on the approximate ratio of 8:13. Also called *divine proportion, golden mean, golden number, golden proportion, golden ratio, golden rectangle, and sectio aurea.*

Golden Section Spiral
A golden section spiral is created when the golden section rectangle is subdivided into a smaller proportional rectangle and the remaining subdivision is a square. Its squares decreasing in size produce a spiral by using a radius the length of the sides of the square. This logarithmic spiral based on golden section proportions is reminiscent of the growth patterns of shells, such as in a cross section of a nautilus shell.

Grid
A grid is a two-dimensional structure composed of a set of horizontal and vertical axes used to position and organize visual elements in a compositional layout.

Ground
The page, surface, or background area of a compositional layout in which visual elements (or figures) are placed. See *figure-ground*.

Gutter
A gutter is a vertical space located between columns of type. Also called *alley* and *column gutter*.

Half Sheet
see Folio (Book Format).

Hang Line

A hang line is a horizontal positioning line in a grid that provides a consistent location for the “hanging” of visual and narrative content (i. e. image and text) in a compositional layout providing a reader with a consistent point to rest their eyes on page after page. Also called *drop line*.

Head Margin

The space located at the top of the page; also called *top margin*.

Header

A header is a separate area located at the top margin directly above the main text area of a compositional layout that traditionally contains a book or chapter title and author’s name.

Hierarchical Grid

A grid system in which both recto and verso pages of a compositional layout consist of a system of alignments and zones for text and images that varies from page to page due to diverse visual and narrative content.

Hierarchy

Hierarchy refers to a logical and organized order of importance applied to the visual elements of a compositional layout, which can be determined by size, spacing, or color.

Horizontal Alignment

see Alignment.

Horizontal Symmetry

Horizontal symmetry is created with an imaginary horizon or a left-to-right line functioning as the divider of a compositional layout with the top and bottom sections mirroring one another. A landscape reflected in a still pond is an example of horizontal symmetry.

Imposition

The arrangement of compositional page layouts in the sequence and position in which they appear when printed before being cut, folded, and trimmed.

Imposition Plan

A series of small-scale sketches or “thumbnails” of the compositional page layouts of a publication, which shows how it is organized in the sequence and position in which the layouts appear.

I - M

Incunabula

Incunabula is a term used to describe a book, pamphlet, or broadside that was printed, not handwritten, prior to 1501 CE in Europe.

Indent

A space indicating the beginning of a new paragraph in running text by insetting the first word.

International Paper Sizes (ISO)

ISO standard paper sizes, also known as ISO (International Standards Organization) metric sizes, is the most common and universal paper size system used extensively throughout the metric-based world. These proportional size standards are based on a rectangle that has a proportional ratio of 1 to the square root of 2 or 1:1.414.

Isometric

An isometric projection is where three visible surfaces of a form have equal emphasis and all axes are rotated simultaneously 30 degrees away from the picture plane and kept at the same angle of projection. All lines are equally foreshortened, and the angles between lines are always 120 degrees.

Jump

The continuation of running text from the bottom of one column to the top of the next column on the same page, onto another page, or across multiple pages.

Junior Legal

A North American standard paper size of 8 inches x 5 inches (203 mm x 127 mm).

Justification

A text setting where lines are equal in length and aligned to both left and right margins of a column. See also *alignment*.

Juxtaposition

The placement of contrasting visual elements next to one another in a compositional layout that communicates different ideas or points of view.

Large Crown

A British standard book size measuring 258 mm x 201 mm (Quarto: 10 inches x 8 inches) and 198 mm x 129 mm (Octavo: 8 inches x 5 inches).

Layout

The arrangement and composition of visual elements such as type, images, and other visual elements on a page or screen.

Le Moduler

LE MODULOR

A proportional system based on human measurements, the double unit, Fibonacci numbers, and the golden ratio created by noted modernist architect Le Corbusier, also known as Charles-Édouard Jeanneret (Swiss, 1887–1965).

Leaf

A leaf is a single sheet within a book or publication and each side of a leaf is a page.

Ledger

A North American standard paper size of 17 inches x 11 inches (432 mm x 279 mm).

Legal

A North American standard paper size of 8.5 inches x 14 inches (216 mm x 356 mm).

Letter

A North American standard paper size of 8.5 inches x 11 inches (216 mm x 279 mm).

Line Length

see Measure.

Line Measure

see Measure.

Linear Perspective

Linear perspective is defined as the convergence of parallel lines toward a single vanishing point located on a horizon or eye-level line. Perspective lines that are located above an eye-level line are drawn diagonally down toward the vanishing point; lines that are located below an eye-level line are drawn diagonally up towards it. Vertical lines indicate height and horizontal lines indicate width; in both orientations, the lines remain parallel. Also called *one-point perspective*.

Live Area

A live area is the active area of a format where visual elements, such as type, images, and other content, are present in a compositional layout.

Location

Location refers to where an element is positioned vertically in a two-dimensional compositional layout. For example, the bottom of a composition is perceived as its foreground, the area nearest to the viewer, and the top of a composition is perceived as its background, the area farthest from the viewer. The higher an element is located in a compositional layout, the farther back it is perceived.

Manuscript Grid

A manuscript grid is the simplest type of grid system and is composed of a primary rectangular text area which is used to display extensive continuous running text. Also called *block grid*.

Marber Grid

A Marber grid is an organizational and compositional page grid system developed by graphic designer Romek Marber (Polish, b. 1925) in 1961 for Penguin Books and is based on the golden ratio.

Margin

The negative space located between columns of type and the formal edge of the page.

Marginalia

Marginalia is the term used to describe text matter, such as headers, footers, and folios or page numbers, which traditionally appear in the page margins.

Marker

A marker is a placement indicator for supporting page information such as running headers or footers, folios or page numbers, or any other repeating element that occupies a consistent location on a page or spread.

Masthead

A masthead is a list of the names and corresponding titles of editors, writers, contributors, and owners involved in a publication or magazine.

Measure

The length of a line of type, based on either inches, centimeters, points, or picas. Also called *column width*, *line length*, and *line measure*.

Metric System

An absolute measurement system based on standard fixed value units of millimeters (0.001 meter, 0.1 centimeter, 0.0394 inch). One millimeter is equal to 2.85 American-British points.

Millimeter

A standard unit of length measurement in the metric system; one millimeter equals one thousandth of a meter or 0.03937 inch.

Module

A module is an individual unit of space within a page grid separated by regular intervals that, when repeated across the page, create columns and rows of varying sizes.

Modular Grid

MODULAR GRID

A modular grid system is composed of a series of horizontal and vertical columns which create modules, usually squares, that are used to organize and display complex information, such as continuous running text and varied scale images found in newspapers, charts, and calendars.

M - R

Moiré

A moiré pattern is a visual effect produced when two, or more, screen angles of a photographic image overlap each other and are not set at their required angles.

Montage

Montage is the process and result of creating a singular image from fragments from other image fragments; derived from the French word for "assemble."

Mosaic

Mosaic is the process and result of creating a singular image from the assemblage of small pieces or fragments of colored glass, stone, ceramic, or other materials.

Movement

Movement refers to the suggestion or illusion of motion evident in visual elements of a compositional layout.

Negative Space

see White Space.

Objective Scale

Objective scale is the actual dimensions of a physical object or a literal visual connection between an actual object and its graphic representation.

Octavo

Octavo is the technical term describing a book or pamphlet format produced by printing eight (8) text pages on each side of a sheet of paper and folding the paper three times to form a signature containing eight (8) leaves or sixteen (16) pages called octavos (eighths). From the Latin word meaning "in eighth" or "for the eighth time."

One-Point Perspective

see Linear Perspective.

Outdent

see Hanging Indent.

Pacing

Pacing is an essential visual and experiential characteristic that assists a reader or user in comfortably and intuitively engaging with the material presented. Compositional layouts, especially in continuous pages of publications and websites, should maintain a meaningful and thoughtful pace and sequence, so that a reader can comfortably interact with the information being presented. If it is irregular or overwhelming, a reader will most likely become tired, frustrated and ultimately stop reading.

Page

A page is either side of a leaf in a book or publication used to present text and images in a compositional layout.

Pagination

Pagination is the process of dividing and organizing the sequential arrangement and numbering of pages in a book or publication.

Passe Partout

A visual border surrounding an image or visual element, which functions as a frame and provides a means of standardizing the presentation of different subject matter. From the French word meaning "mat."

Pattern

Pattern is a specific type of visual texture and is traditionally derived from a defined and repeated compositional structure that always appears in an organized and regimented manner.

Photomontage

Photomontage is the process and the result of creating a singular composite photographic image by cutting, gluing, rearranging, and overlapping two or more photographic images into a new image.

Physical Space

Physical space is the threedimensional world. A wayfinding sign program for an airport, an exhibition of art and artifacts in a museum, or a large-scale display for an urban retailer are all representative examples of physical compositional space.

Pica

A typographic unit of measurement where twelve (12) points equal one pica (1/6 inch or 0.166 inch) and six (6) picas equal one inch (0.996 inch).

Pictorial Space

Pictorial space is the manipulation of a flat surface to create a perception of depth.

movement, or direction, and relies on optical illusion to deceive the mind and eye of a reader.

Plan Oblique
see Axonometric.

Planar Perspective

Planar perspective is when two visible sides of an element stretch away toward two vanishing points located in the distance on an eye-level line. Vertical lines within the composition remain parallel to one another. The remaining lines that appear parallel in the composition also appear to diminish diagonally toward one of the two vanishing points located to either side of the eye-level line. Also called *two-point perspective*.

Point

An absolute measurement system used in typography and based on standard fixed values of units of the pica and the point measuring 0.166 and 0.01383 inches, respectively. There are twelve (12) points in one pica and six (6) picas, or seventy-two (72) points, in one inch.

Point Size

The height of the body of a typeface, measured as the distance from the top of the tallest ascender to the bottom of the lowest descender. See also *body size*.

PostScript

A page description language developed by Adobe in 1983.

Preferred Numbers

Preferred numbers are a proportional system based on dividing a compositional layout format into proportions that are visually more dynamic and harmonious than if they were simply divided into equal segments.

Proportion

Proportion is a fundamental design principle that defines the systematic relationship of one visual element to another in any compositional layout.

Proximity

Proximity is a term used to describe the placement of visual elements close together in a compositional layout so that spatial and informational relationships between them are created. For example, locating a caption close to an image conveys that the caption relates to the image.

Psychological Space

Psychological space is a visual composition that influences the mind and eye of a

reader.

Quarto

Quarto is the technical term describing a book or pamphlet format produced by printing four (4) text pages on each side of a sheet of paper and folding the paper twice to form a signature containing four (4) leaves or eight (8) pages called quartos (fourths). From the Latin word meaning “fourth.”

Radial Balance

Radial balance is based on a circle and occurs when visual elements in a compositional layout radiate out from a central, common point in a circular direction and their visual weight is equally distributed.

Rail

A rail is a narrower, full-height column (typically half the width of adjacent columns) located either at the far left or far right of a page grid. This column type was predominantly used for directory-type information in tabloids and newspapers during the late 1990s and early twenty-first century.

Ranged Left

see Alignment.

Ranged Right

see Alignment.

R - T

Rational Spacing

see Fibonacci Sequence.

Recto

The right-hand page of a compositional layout or page spread. From the Latin term “recto folio,” meaning right-hand leaf or page.

Reflective Symmetry

Reflective symmetry is created by mirroring equivalent visual elements around a central axis of a compositional layout. This type of symmetry can be achieved in any orientation (horizontal or vertical) as long as its elements are the same on both sides of a central axis. Forms found in nature, such as a monarch butterfly, exhibit reflective symmetry. Also see *horizontal symmetry, vertical symmetry.*

Relative Measurement

A relative measurement system, as in typography, is based on rational values such as character spacing, fractions, and dashes which are directly linked to the type size they are set in, which is measured by a relative (rather than absolute) measurement system. As the size of the typeface changes so does the relative size of its typographic characters and glyphs since they are measured by the basic unit of an em.

Renard Numbers

A system of preferred numbers, developed by engineer Charles Renard (French, 1847–1905), that divides an interval from 1 to 10 into 5, 10, 20, or 40 steps. The numerical factor between these two consecutive numbers is an approximate constant, namely the 5th, 10th, 20th or 40th root of 10, or approximately 1.58, 1.26, 1.12, and 1.06 respectively, which is a geometric sequence.

Repetition

The repeated use of visual elements in a compositional layout.

Reversal Figure-ground

A figure-ground reversal is created when a figure functions as a ground and ground as figure. This graphic inversion is caused by shapes that form in the spaces located between the figure, thereby creating the reversal.

Rhythm

A term used to describe the visual movement of a compositional page layout, either between its elements or from page to page. It is usually described as regular, flowing, or progressive.

A regular rhythm occurs when spatial intervals between compositional elements or pages, and the elements themselves, are similar in size, length, or visual character. A flowing rhythm occurs when compositional elements or page layouts are organic and natural in visual character. A progressive rhythm occurs when a sequence of compositional elements or pages progresses visually through a defined series of steps.

Root Rectangle

see Dynamic Rectangle.

Rotative Symmetry

Rotative symmetry is created in a compositional layout by rotating equivalent elements in an outward direction from a common center point while drawing attention inward. Arabesque and mandala patterns are examples of man-made rotative symmetry. Natural forms, such as a sunflower, are also examples of rotative symmetry.

Row

A row is the horizontal equivalent of a column.

Royal

A British standard book size measuring 312 mm x 237 mm (Quarto: 12.25 inches x 9.5 inches) and 234 mm x 138 mm (Octavo: 8.5 inches x 5.5 inches).

Rule of Thirds

A proportional system based on the theory that the human eye is naturally drawn to intersection points that occur when an image is split into thirds.

Running Header (or Footer)

A running header is a visual guide located at the top of a page indicating a reader's position in a book or publication. Information such as the book or publication title, chapter title, section title, author, and folio or page number is typically displayed in a running header. A running footer is the same element and information located at the bottom of a page.

Scale

Scale is relative and based on proportion. Its visual characteristic in a compositional layout can be categorized as either objective or subjective. See also *objective scale* and *subjective scale*.

Section Aurea.

see Golden Section.

Sequence

see Pace.

Shape

Shape refers to the different contours or outlines of visual elements in a compositional layout.

Signature

Two or more sheets of paper of a book or publication, folded or connected at their binding edge.

Simple Figure-ground

A simple figure-ground is created when the figure is positive and active, and its ground is always negative and passive. In this compositional relationship, the figure is clearly visible and separate from its background.

Space

Space is an essential visual element that cannot be placed or located in a compositional layout. It refers to the distance or area between, around, above, below,

or within other visual elements such as shapes, forms, and images, in a compositional layout. It can be two-dimensional or threedimensional and described as flat, shallow, deep, open, closed, positive, negative, actual, ambiguous, or illusory.

Spatial Zone

A spatial zone is a group of modules that form distinct fields within a page grid for displaying similar information in a consistent manner. Also called *field*.

Subjective Scale

Subjective scale refers to an individual's impression of an actual object. This type of scale is relative only to an individual's experiences and is, therefore, subjective in nature.

Symmetrical Single-Column Grid

A symmetrical grid in which the recto and verso pages of a compositional layout mirror one another and are composed of a single-column grid per page.

Symmetrical Double-Column Grid

A symmetrical grid in which the recto and verso pages of a compositional layout mirror one another and is composed of a double-column grid or two equal measure columns per page.

Symmetrical Multiple-Column Grid

A symmetrical grid in which the recto and verso pages of a compositional layout mirror one another and is composed of a multiple-column grid or multiple equal measure columns per page.

Symmetrical Grid

A grid system in which the recto and verso pages of a compositional layout mirror one another and the inner margins of both pages are the same width as the outer margins, providing a symmetrical, or balanced, visual appearance to the page spread.

Symmetry

Symmetry occurs when visual elements are arranged on either side of a compositional layout as equal and identical to one another and appear as a mirror image. Also called *formal balance* and *bilateral symmetry*.

Tabloid

A North American standard paper size of 11 inches x 17 inches (279 mm x 432 mm).

T - W

- .

Tension

Tension refers to the different levels of harmony or discord established between the visual elements of a compositional layout.

Tessellation

A pattern of flat shapes that fit perfectly together and possess no overlaps or visual gaps.

Texture

Texture refers to the visual or tactile surface characteristics and appearance of visual elements of a compositional layout.

Top Margin

see Head Margin.

Translative Symmetry

Translative symmetry is created by locating equivalent elements in different areas of a compositional layout. This type of symmetry can occur in any direction and over any distance, as long as the basic orientation of its elements is maintained. Continuous patterns found in architectural surfaces such as friezes and brick facades, are examples of translative symmetry.

Two-Point Perspective

see Planar Perspective.

Unit

A variable measurement based on the width of a letterform or character including white space on either side, not including kerns.

Unity

Unity is a term used to describe the joining of disparate visual elements together in a compositional layout to create a unified, cohesive whole.

Value

A fundamental property of color defined by the lightness and darkness of a color.

Van de Graaf Canon

The Van de Graaf Canon is a proportional system based on a historical reconstruction of a proportional system that may have been used to organize a page in pleasing proportions. It is evident in medieval manuscripts and incunabula, as well as in the work of early bookmakers and publishers such as Johannes Gutenberg (German, 1395–1468).

Verso

The left-hand page of a compositional layout or page spread. From the Latin term “verso folio,” meaning left-hand leaf or page.

Vertical Alignment
see Alignment.

Vertical Symmetry
Vertical symmetry is created with an imaginary vertical or a top-to-bottom line functioning as the divider of a compositional layout, with the left and right sections mirroring one another. A Rorschach ink blot is an example of vertical symmetry.

Villard Diagram
A proportional system based on architect Villard de Honnecourt’s (French, 1200–1250) Villard diagram in which he divided a straight line into logical and harmonious divisions of thirds, fourths, fifths, and so on.

Weight
The perceived physical weight of an element in any compositional layout contributes to its visual interest. For example, a visually heavier element has more visual interest than a visually lighter element of the same size.

White Space
The inactive space that surrounds active, visual elements in a compositional layout. Also called *negative space*.

Widow
A single word or line of text at the beginning of a paragraph located at the bottom of a page or column of text.

Test your Knowledge

1. What are the primary distinctions of a margin and gutter in a grid system?
2. What are the primary distinctions of a column, module, and spatial zone in a grid system?
3. What is the difference between a fore-edge and back-edge in a grid system?
4. What are three primary typographic characteristics that need to be considered when establishing a column width and measure?
5. What is a recommended character count per text line for any given line length or column width for optimum readability?
6. In a modular grid system, what anatomical elements of a grid are used to create modules?
7. What is the term used to describe a group of modules in a grid system that form distinct fields in a compositional layout?
8. What is another name for the horizontal alignment element in a grid system that organizes visual and narrative content into defined areas in a compositional layout?
9. A marker is a placement indicator in a grid system for what type of visual and/or narrative content?
10. Identify three (3) locations on a page grid where gutters can be used and/or located?

For answers to Test your Knowledge, see [here](#).

Note: All grid diagrams in this section reflect the page grid used in this volume.



Section 3

Grid Systems

For centuries, whenever there has been a need to build an object, divide an area, or enhance a flat surface, some form of a grid system has been used. The grid has been relied upon as a guiding organizational and compositional principle by Renaissance artists as a method for scaling sketches and images to fit the proportion of murals, by cartographers in plotting map coordinates, by architects for scaling drawings and plotting perspective views, and by typographers in the design of letterforms and the printed page. Prior to the invention of movable type and printing in the fifteenth century by Johannes Gutenberg (German, 1395–1468), simple grid systems based on various proportional relationships were used to arrange hand written text on pages. While grid systems evolved over the next five hundred years, they remained largely the same in structure and use.

A grid system can be used to solve a wide range of design problems and is an effective organizational and compositional tool for the layout of newspapers, magazines, books, annual reports, brochures, catalogs, sign systems, corporate identity and branding programs, and websites.

As a flexible compositional tool, a grid can assist you in creating either static, symmetrical layouts, or active, asymmetrical ones. The basic construction of any grid can be orthogonal, angular, irregular, or circular. It can be an invisible and functional layer of a compositional layout or it can be an obvious and dynamic visual element.

A graphic designer should always consider the structure of a grid system based on their thorough analysis of the visual and narrative content to be used. This will allow a considerable degree of flexibility when composing and arranging disparate elements, such as text and images, on a grid and ultimately the compositional page layout, be it twodimensional, three-dimensional, or virtual.

A grid system can be visible or invisible; an implied framework or an obvious design element. It is also an essential design principle for organizing and presenting complex, multifaceted information in a systematic manner. Publications, websites, sign systems, advertising campaigns, and corporate communications are all comprised of multiple pages, each requiring a slightly different compositional layout due to their varied content.

If a grid system is well planned and conceived, it provides you with an efficient way in which to create multiple compositional layouts while maintaining visual consistency and cohesiveness to a book, publication, or website.

The development of the grid has been an evolutionary process. No one artist or graphic designer can be identified as its sole creator or inventor; however, many creative minds have contributed to its development and will continue to influence its further refinement over time.

The Modern Grid System

Fundamentally, a grid system is a twodimensional structure composed of a series of horizontal and vertical axes that provide a series of alignments and intersections to position and organize visual elements in a compositional layout. It is a fundamental design principle of all graphic design. Similar to many other elements and principles in graphic design, a grid system's functions are limitless. It can provide order and visual unity, as well as enhance the rhythm and pacing of any compositional layout.

A typographic page grid is a twodimensional organizational framework used to structure content. It is an armature for you to organize narrative and visual content in a rational, aesthetic, and accessible manner.

In the early 1950s, a group of innovative European graphic designers including Max Bill (Swiss, 1908–1994), Emil Ruder (Swiss, 1914–1970), and Josef Müller-Brockmann (Swiss, 1914–1996), influenced by the modernist tenets of Jan Tschichold's *Die Neue Typographie (The New Typography, 1928)*, began to question the relevance and use of the conventional page grid.

The result was the development of the modern typographic grid that became associated with the International Typographic Style, also known as the Swiss School, which provided graphic designers with a flexible grid system for achieving variations of the printed page. A seminal reference book on this subject, *Grid Systems in Graphic Design* (1981), written by Müller-Brockmann, helped propagate the use of the modern grid system, first in Europe, and later throughout the world.

Functions

Graphic design carries its message and meaning through the organization and arrangement of disparate design elements within a compositional layout. The clarity and immediacy of any message is reinforced with visual unity through the use of a grid. It is a useful tool for any graphic designer. It provides you with a

framework for compositional layout through its network of horizontal and vertical intersecting lines that organize and divide the page into field and interval, thereby creating a guide for establishing proportional relationships between the compositional layout's design elements.

The grid is an invaluable principle of a graphic designer's vocabulary, as well as an essential tool that you can use in the increasingly complex production of print-based and digitally-based graphic design. It can be used to organize, compose, separate, enlarge, reduce, and locate visual elements. Grid construction can be loose and organic or rigorous and mechanical. When used correctly and appropriately, a grid brings simplicity, clarity, efficiency, flexibility, economy, continuity, consistency, and unity to any compositional layout.

A grid, like any other element used in the design process, is not an absolute. It should be used with flexibility and, when necessary, be modified or even abandoned for a more intuitive solution. It can be developed as a simple framework that has an obvious and integrated relationship to its narrative and visual content, or it can be composed of more complex forms and proportions that provide more varied and nuanced results.

Müller-Brockmann maintains that "the grid system is an aid, not a guarantee. It permits a number of possible uses and each designer can look for a solution appropriate to their own personal style. But one must learn how to use the grid: it is an art that requires practice."

As a counterpoint to this view, Charles-Édouard Jeanneret-Gris (Swiss, 1887–1965), also known as Le Corbusier, a pioneer of modernist architecture and the International Style, in his comments about his grid system called *Le Modulor* points out: "I still reserve the right, at any time, to doubt the solutions furnished by the *Modulor*, keeping intact my freedom which must depend on my feelings rather than my reason."

The use of an underlying grid system further enhances the legibility and balance of any compositional layout. When it is composed of many pages, such as in a book, magazine, or website, the use of a grid also further guarantees continuity and unity.

Contemporary Influence:

Massimo Vignelli and Grid Systems

In 1960, after completing his architectural studies in Milan and Venice, graphic designer Massimo Vignelli (Italian, 1931–2014) moved to the United States as co-founder and design director of Unimark International, at the time one of the largest design consultant firms in the world. During the 1960s, Unimark and Vignelli designed many of the world's most recognizable corporate identities and public information systems for clients such as American Airlines, Ford Motor Company, and Knoll International, as well as the iconic program for the New York City subway system.

While Vignelli's typographic range expanded beyond the sole use of Helvetica for Unimark's clients to include classical typefaces such as Bodoni, Century, Garamond, and Times Roman, he retained and strengthened a rational use of grid systems and an emphasis on clear, precise, and objective graphic design.

One primary example of this philosophy was evident in the early 1970s with the design of *The Herald* newspaper. Prior to this time period, newspapers and tabloids were one of the most neglected areas of visual communications. In 1971, Vignelli Associates was given the opportunity to design *The Herald*, a new weekly newspaper for the New York City tri-state area. *The Herald* was structured on a page grid of six (6) columns with sixteen (16) modules per column. One typeface, Times Roman, was used throughout the publication, with one type size for all continuous narrative text, two type sizes for titles and subtitles, and the use of italic for captions and decks. Every page constituted a section of the whole

paper, and all pages were structured with clear horizontal bands, which provided a strong, easy-to-read accessibility to the paper's editorial content. The reliance on a fully articulated page grid, as well as a unified set of design specifications,



ensured that the paper would be equipped for fast production and quick turnaround.

Unfortunately, the newspaper folded in less than a year due to union and distribution problems. However, the use of the grid system as an organizational, compositional, and production principle proved to be successful and was subsequently used by designers and publishers as an effective tool for the redesign of numerous newspapers and tabloids in the coming years.

Image: ©Vignelli Associates.

A well-planned grid system can provide you with an endless number of compositional opportunities. It is also your responsibility to consider new ways of approaching grid systems when considering one for a specific application. Every design problem is different and therefore requires a grid system that meets its specific needs.

To better understand, appreciate, and recognize the multitude of anatomical elements applicable to any grid system (as defined in *Section 2*), as well as the similarities and differences between them, a well-rounded and informed graphic designer needs to be familiar with all of their forms, structures, and nuances. Each grid system, from the simple framework of a manuscript grid (see [here](#)) to the more complex one in a hierarchical grid (see [here](#)), has distinct and unique appearances, as well as characteristics and features that ultimately produce a compositional layout based on how you utilize and compose visual and narrative content.

Each grid system is composed of a set of alignment-based elements that function as guides for organizing and displaying visual elements in a compositional layout. These anatomical elements are common to each grid system, whether simple or complex in structure, and can be combined (or not), to meet the needs of your visual and narrative content needs and objectives.

This essential understanding will ultimately affect your visual judgements and facilitate better and more meaningful decisions in making selections and applications with any grid system.

A carefully designed page grid provides a graphic designer with a series of specific spatial relationships and parameters that eliminate the need for random or arbitrary decisions when it comes to compositional layout. This further ensures that all visual elements used in a compositional layout will work well together and facilitate a cohesive and informed end result.

Manuscript

A manuscript grid, also known as a block grid, is the simplest type of grid system. It is derived from written manuscripts of the early fourteenth and fifteenth centuries and is composed of a primary rectangular text area that is used to display extensive continuous text as in a novel or long narrative essay. Classical manuscript grids mirror the left and right page text block with a wider inner margin.

The secondary elements of this grid may also include running headers or footers, chapter or section titles, and folios or page numbers. In some cases, a consistent area for footnotes and references may be needed. Please refer to *Section 2* for specific definitions of the above-referenced terms.

Even when working with the simplest of grid systems, such as a manuscript grid, careful attention needs to be given to the extent and area used for continuous narrative text so that a reader is comfortable engaging and interacting with page after page of text information. Large, continuous areas of type can be monotonous and overwhelming for a reader, therefore creating visual interest and variation, subtle or obvious, is critical to maintaining a reader's attention.

One of the most effective ways of adding visual interest and variation to compositional layouts that use a manuscript grid is the adjustment of its margins' proportions. For example, wider margins create focus for a reader, as well as creating a sense of stability in a compositional layout. Narrower, lateral margins create visual tension because compositional elements are in close proximity to the edge of the printed or digital page. Variations in margin sizes can provide a compositional layout with limited or ample white space for you to activate, if needed. Additionally, inner margins should always be wide enough to prevent compositional elements, specifically narrative text, from becoming lost within the inner margins or gutters of a two-page spread.

Traditionally, gutters are usually treated as inactive spaces on most page grids, used to visually separate columns of continuous narrative text from one another. Like horizontal and vertical margins, the proportions and widths of gutters can also have a dramatic visual impact on the final overall appearance of a compositional layout. The readability and accessibility of narrative and visual content are also important considerations when finalizing the proportions and widths of a page grid's gutters.

While the more traditional approach with a manuscript grid is a symmetrical organization of equal width columns and margins, an asymmetrical grid structure relies on variable margin intervals and dimensions, which create more white space on the page, as well as potential locations for secondary and tertiary

page information such as spot illustration or footnotes, headers, footers, chapter or section titles, and folios or page numbers.

Since type is the sole element used in a manuscript grid, great care should be taken to ensure that the size of the live text area is resolved in a manner that affords the reader ease and comfort throughout their interaction with multiple spreads. Subtle variations in type size, leading, spacing, color, emphasis, and alignment are also important considerations that can provide added visual hierarchy to the page, spread, and document.

Manuscript Grid

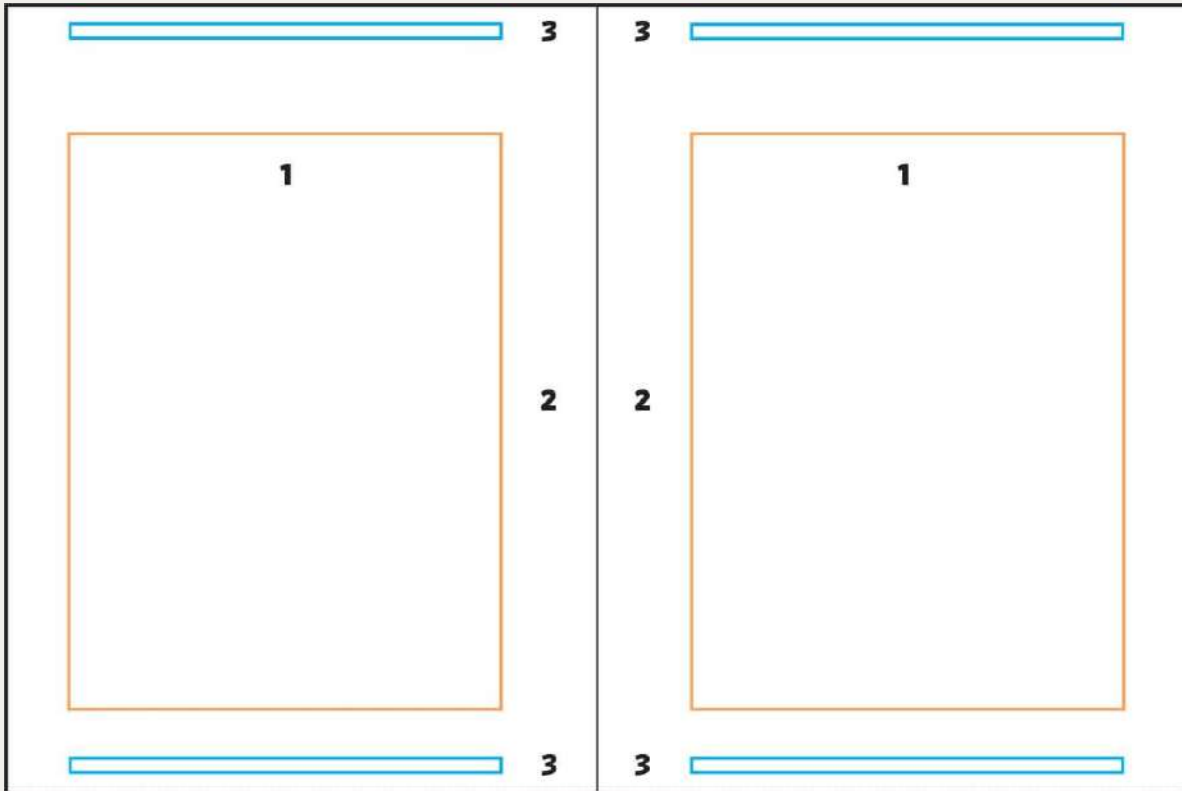

SYMMETRICAL

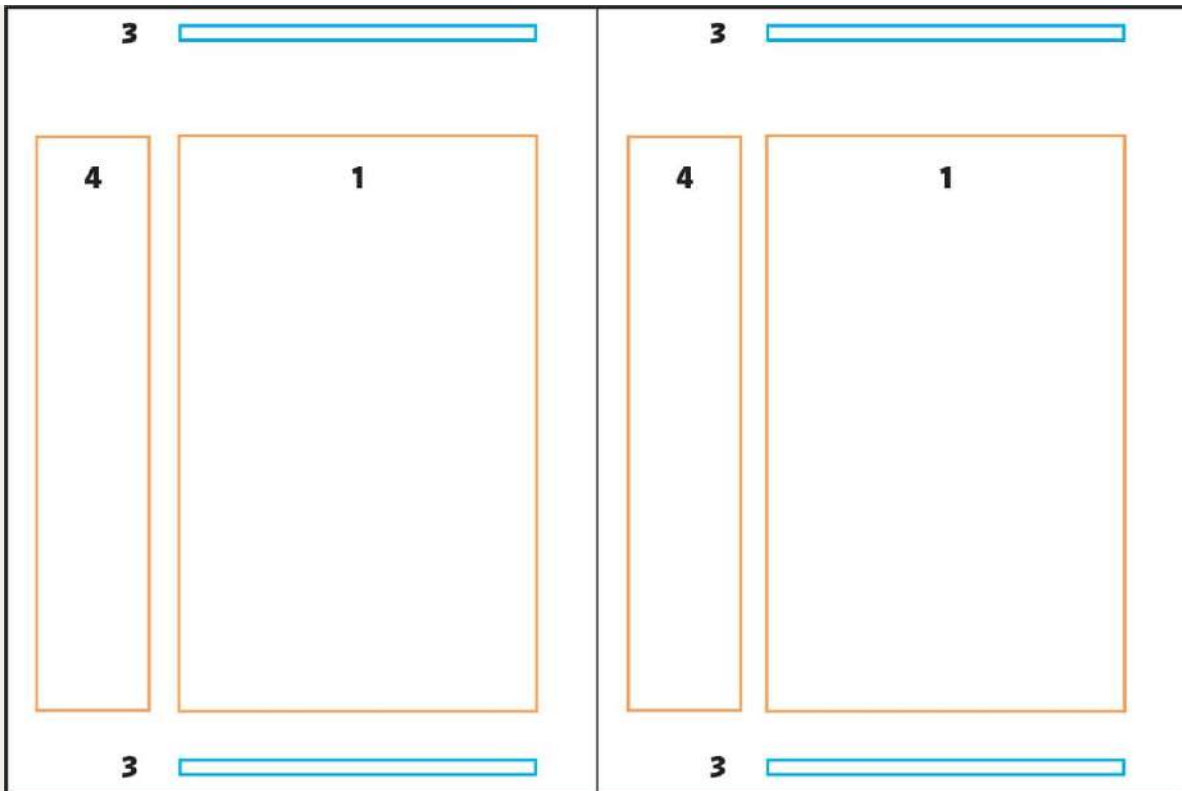

ASYMMETRICAL

GRID CHARACTERISTICS

1. Text Area

A single area for extensive continuous text; the grid is mirrored on left and right pages.

2. Margins

Wide inner margins are a typical feature of manuscript grids.

3. Secondary

Secondary elements may include headers or footers, chapter or section titles, and folios or page numbers.

4. Asymmetry

Asymmetrically located text areas create zones for additional information such as spot illustrations.

Symmetrical Grid

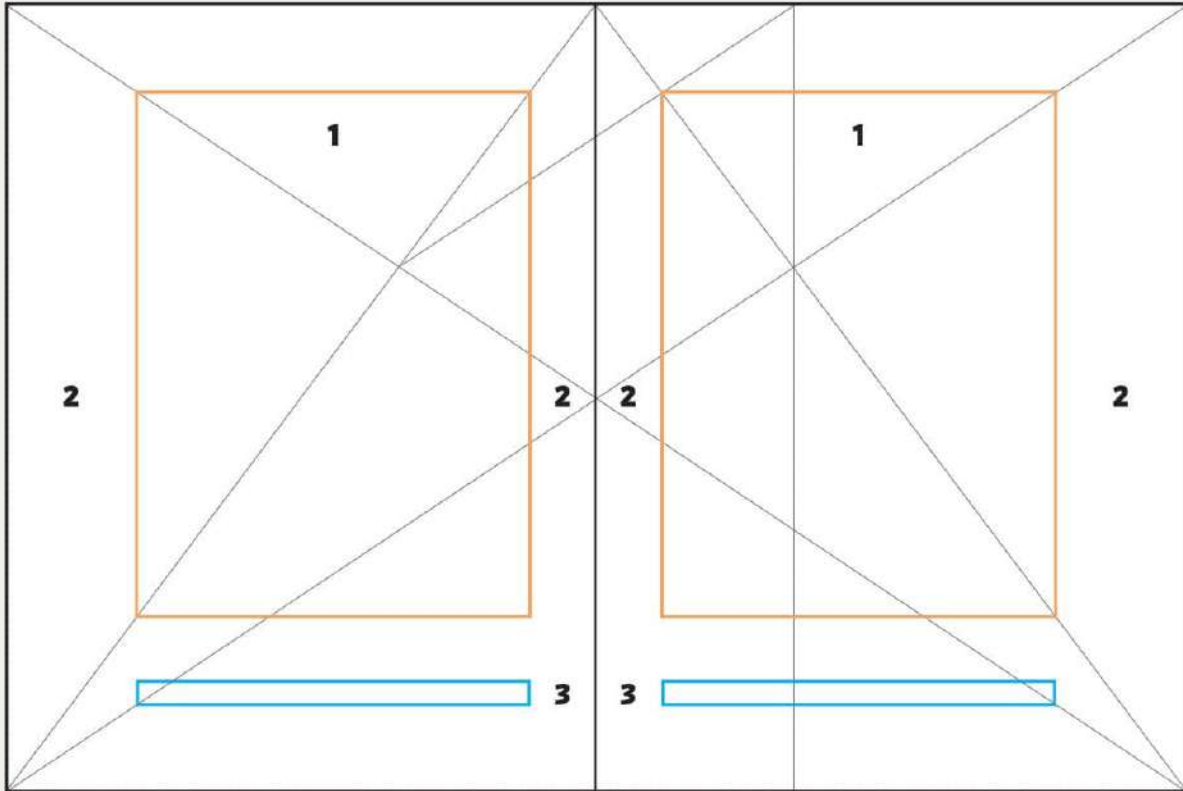

SINGLE-COLUMN

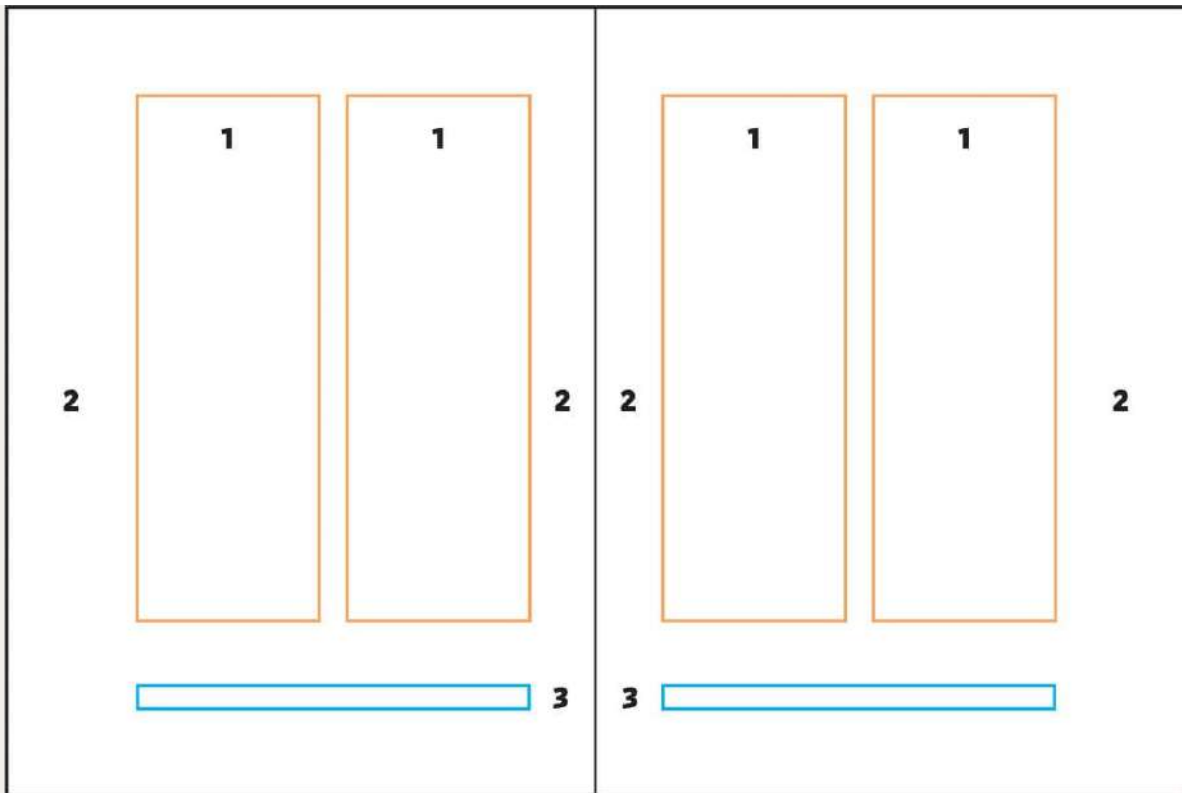

DOUBLE-COLUMN

GRID CHARACTERISTICS

1. Text Area

The text area in this symmetrical grid is derived by page spatial relationships.

2. Inner/Outer Margins

Symmetrical grids have equal inner and outer vertical margins.

3. Secondary

Secondary elements may include headers or footers, chapter or section titles, and folios or page numbers.

Symmetrical (Single-, Double-, and Multiple-Column)

A symmetrical grid is the basis for a compositional layout where both the left- and right-hand pages (verso and recto) are mirror images of one another and the inner margins of both pages are the same width as the outer margins, providing a symmetrical, balanced visual appearance to the page spread. The left-hand page of a compositional layout or page spread is called verso, from the Latin term *verso folio*, meaning left-hand leaf or page. The right-hand page of a

compositional layout or page spread is called *recto*, from the Latin term *recto folio*, meaning right-hand leaf or page. In this context, each page's live text area comprising a single-, double-, or multiple-column grid system and inner and outer margins, is the same measurement, bringing a consistent organization and visual balance to narrative and visual content.

Multiple-column grids provide you with greater flexibility than a single-or double-column grid system since they utilize multiple columns of varied widths and measures, making them extremely effective for magazines and websites.

Single-Column

One variation of a symmetrical grid can be based on the grid's simplest form—a singular block or single-column symmetrical composition of continuous narrative text with two equal inner and outer vertical margins. This symmetrical grid type is most prevalent in applications of continuous narrative text found in books and essays.

When using a singular block or single-column of continuous narrative text, you should be aware of the optimum character count per line or measure depending on type style and size used. If the character count is too great, the text will be difficult for the reader to engage with from line to line. A maximum of sixty (60) characters per line or measure is recommended. Please refer to *Section 2* for further information.

The final proportions, as well as the width and height, of a page grid's margins also has a tremendous influence on the overall feel of a compositional layout. Margins that are wider in proportion convey a feeling of balance and stability whereas margins that are narrower in proportion convey a feeling of restraint and tension.

Here, all visual nuances of the page spread proportion and margins are derived by spatial relationships rather than relying on a measurement system.

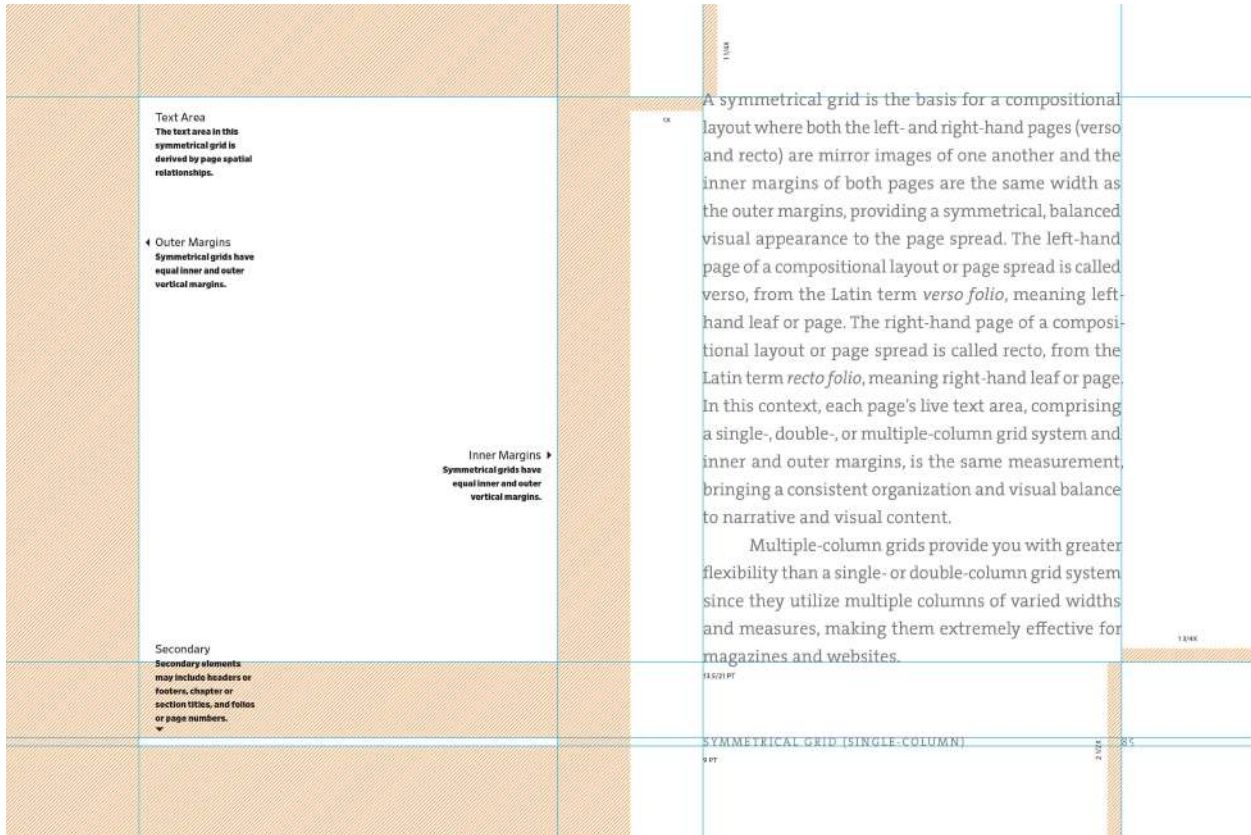

A symmetrical grid is the basis for a compositional layout where both the left- and right-hand pages (verso and recto) are mirror images of one another and the inner margins of both pages are the same width as the outer margins, providing a symmetrical, balanced visual appearance to the page spread. The left-hand page of a compositional layout or page spread is called verso, from the Latin term *verso folio*, meaning left-hand leaf or page. The right-hand page of a compositional layout or page spread is called recto, from the Latin term *recto folio*, meaning right-hand leaf or page. In this context, each page's live text area, comprising a single-, double-, or multiple-column grid system and inner and outer margins, is the same measurement, bringing a consistent organization and visual balance to narrative and visual content.

Multiple-column grids provide you with greater flexibility than a single- or double-column grid system since they utilize multiple columns of varied widths and measures, making them extremely effective for magazines and websites.

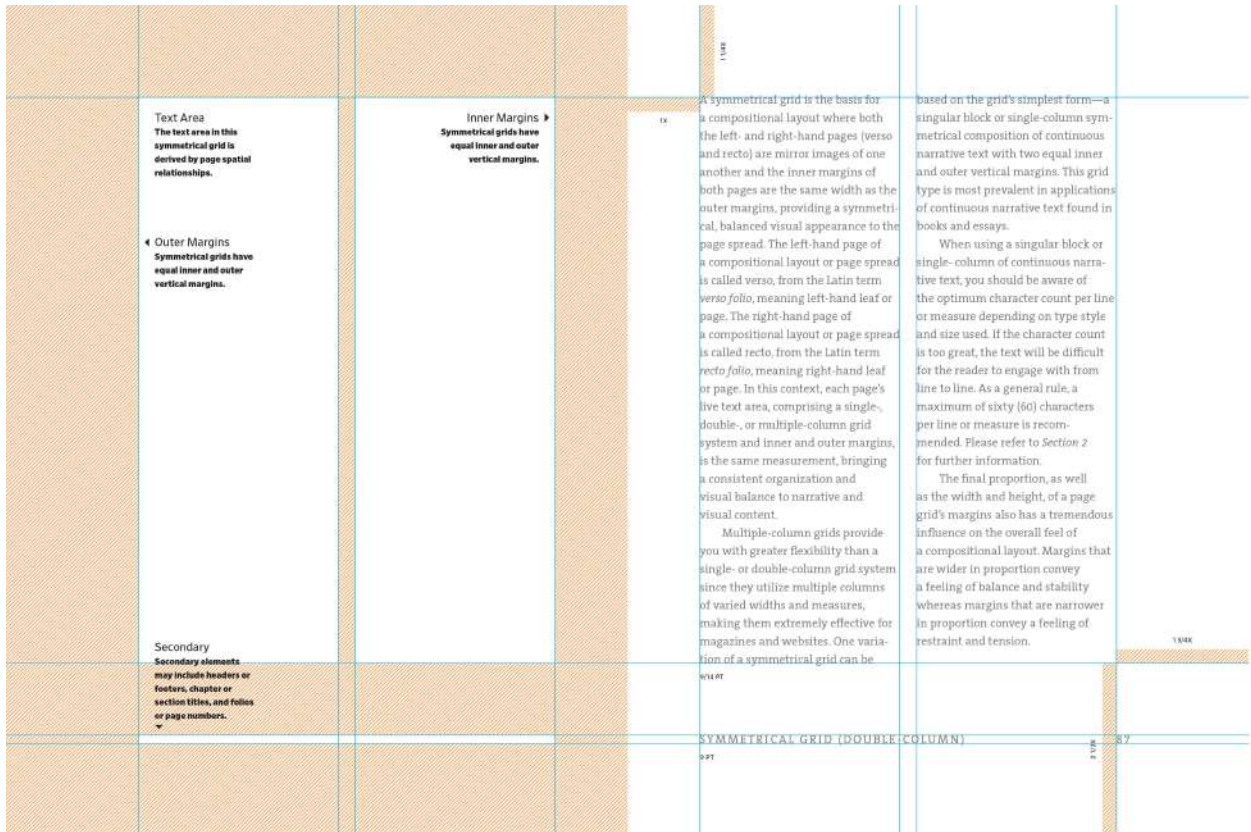

A symmetrical grid is the basis for a compositional layout where both the left- and right-hand pages (verso and recto) are mirror images of one another and the inner margins of both pages are the same width as the outer margins, providing a symmetrical, balanced visual appearance to the page spread. The left-hand page of a compositional layout or page spread is called verso, from the Latin term *verso folio*, meaning left-hand leaf or page. The right-hand page of a compositional layout or page spread is called recto, from the Latin term *recto folio*, meaning right-hand leaf or page. In this context, each page's live text area, comprising a single-, double-, or multiple-column grid system and inner and outer margins, is the same measurement, bringing a consistent organization and visual balance to narrative and visual content.

Multiple-column grids provide you with greater flexibility than a single- or double-column grid system since they utilize multiple columns of varied widths and measures, making them extremely effective for magazines and websites. One variation of a symmetrical grid can be

based on the grid's simplest form—a singular block or single-column symmetrical composition of continuous narrative text with two equal inner and outer vertical margins. This grid type is most prevalent in applications of continuous narrative text found in books and essays.

When using a singular block or single-column of continuous narrative text, you should be aware of the optimum character count per line or measure depending on type style and size used. If the character count is too great, the text will be difficult for the reader to engage with from line to line. As a general rule, a maximum of sixty (60) characters per line or measure is recommended. Please refer to *Section 2* for further information.

The final proportion, as well as the width and height, of a page grid's margins also has a tremendous influence on the overall feel of a compositional layout. Margins that are wider in proportion convey a feeling of balance and stability whereas margins that are narrower in proportion convey a feeling of restraint and tension.

Double-and Multiple-Column

A symmetrical grid can also be composed of double-or multiple-columns of equal measure per page of continuous narrative text based on the needs and content that you are working with.

For example, a double-column, symmetrical page grid provides you with a greater degree of creative freedom and flexibility in organizing and composing type and image than a single-column, symmetrical page grid. The double-column grid system can be used for extensive narrative text or different types of narrative text information that needs to be organized in separate and distinct visual fields or columns. It can be structured in two columns of either equal width or unequal width depending on the nature of the content, as well as the needs of a reader and how they can access this information in the most immediate and understandable manner.

Multiple-column grid structures work best for editorial needs where visual and narrative content are constantly changing. However, you should be careful with how many columns within any grid system you utilize, since too many columns will create a confusing and overbearing compositional layout for a reader. Format size and the complexity of the narrative and visual content will provide you with further insight into the final number of columns to be used.

As with a single-column grid, one of the most important considerations that you need to take into account when developing a multiple-column page grid is column width. Wider column widths and longer line lengths create eye strain, causing a reader to lose their place when reading. Narrower column widths or shorter line lengths fragment text settings and create excessive hyphenations, forcing a reader to become distracted since they are constantly returning to a new line of text.

Column widths and line lengths will vary greatly based on the subject matter and application of the text. For example, in most novels a wider column width and line length is commonly used since a reader has a singular focus and needs to scan long lines of continuous text. In newspapers and magazines, shorter column widths and line lengths organized in multiple text columns are more effective for a reader to easily scan information in a selective manner.

An optimum measure or character count of sixty (60) to seventy-two (72) characters (including word spaces) per text line for any given column width and line length is recommended for optimum readability and legibility. This criterion changes depending upon type selection, size, and style. A measure or character count of forty (40) to fifty (50) characters (including word spaces) per text line is recommended if multiple columns are used. To determine an optimum line

length or measure, you should always carefully evaluate the size of continuous narrative text to be used by changing type size, leading, and spacing to determine a comfortable and appropriate column width. Please refer to *Section 2* for further information.

Word spacing is also a critical spatial consideration that has a direct influence on the readability of any text setting. Minimal word spacing creates difficulty for a reader distinguishing one word from another whereas excessive word spacing causes a visual separation between words, creating a disjunctive and disruptive reading experience.

In addition to column width and line measure, margin width and proportion are critical elements for you to consider when finalizing any grid system. Margins that are wider than column gutters tend to force the reader's eye inward. An effective approach for defining widths for columns, gutters, and margins is to establish a dimensional or proportional relationship between both so that they have obvious spatial and visual relationships, bringing a holistic approach to the overall page grid.

Symmetrical Grid

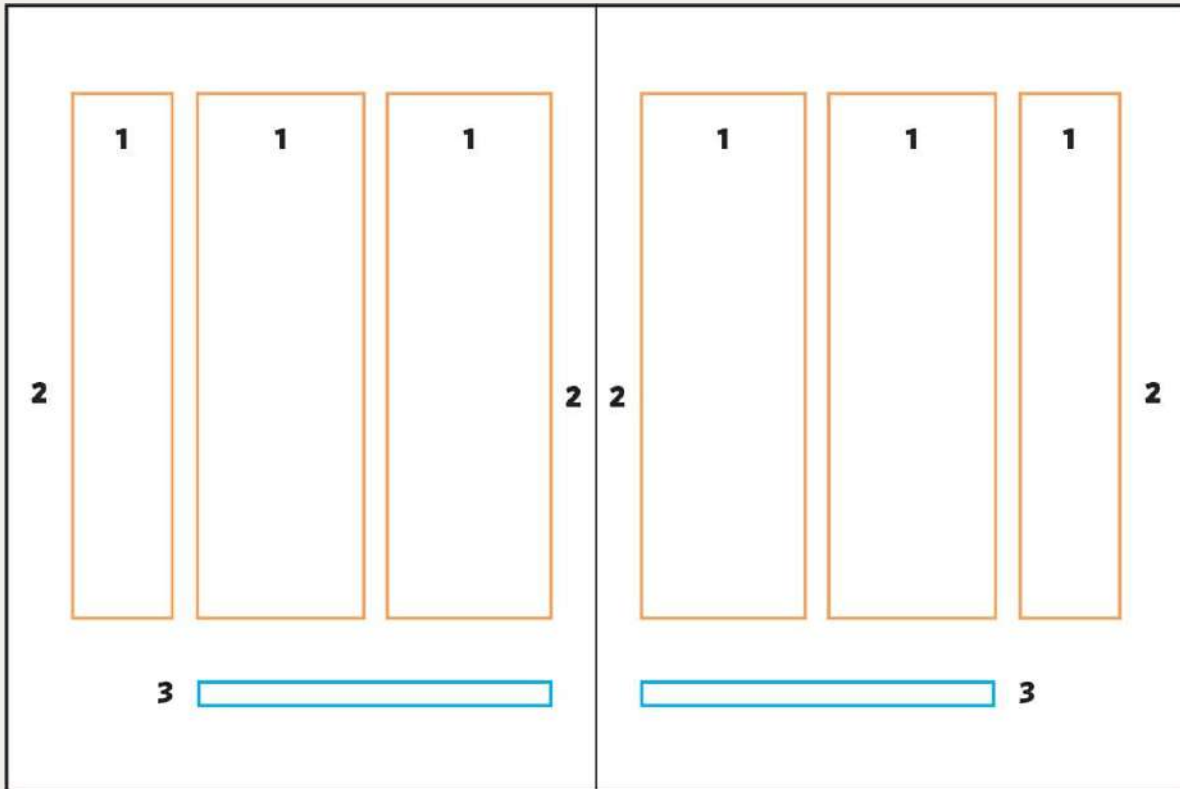

MULTIPLE-COLUMN

GRID CHARACTERISTICS

1. Narrow Column/Wide Column

Multiple columns can be structured in unequal widths for different types of narrative information that needs to be organized in separate or distinct visual fields.

2. Inner/Outer Margins

Symmetrical grids have equal inner and outer vertical margins.

3. Secondary

Secondary elements may include headers or footers, chapter or section titles, and folios or page numbers.

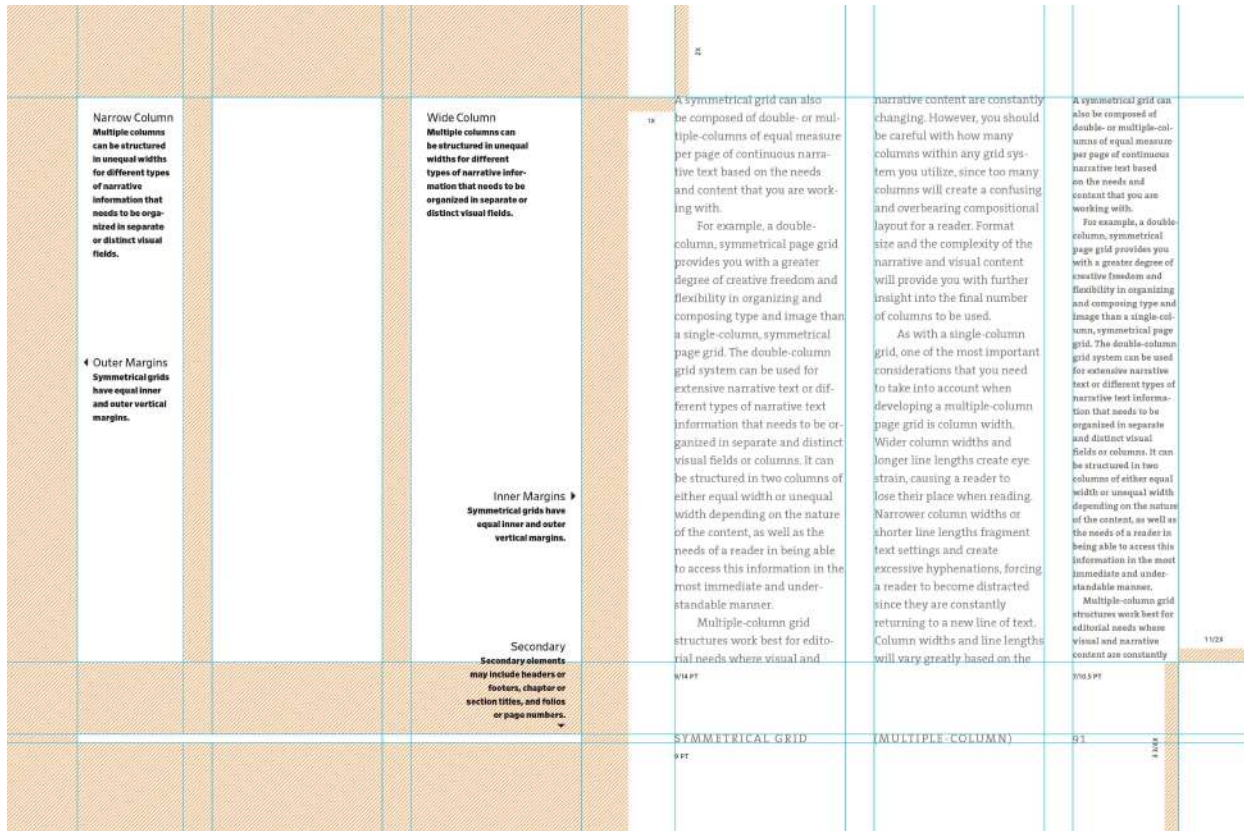

Modular

A modular grid is a compound grid system composed of multiple horizontal and vertical columns that form distinct fields or spatial zones (usually squares) that can be combined both vertically and horizontally in a compositional layout for organizing narrative and image content in a consistent manner.

This grid system is essentially a multiple-column grid with a series of horizontal flowlines that subdivide the multiple vertical columns into multiple rows, thereby creating a framework of modules that can be activated individually or grouped together as spatial zones. While a smaller-sized module will provide you with greater flexibility and control in a compositional layout, the reliance on too many modules may create confusion and redundancy for the reader.



MVRDV Buildings Joost Grootens Studio Amsterdam, NL A modular page grid is used as an effective organizational design tool for this monograph. This compound grid system provides maximum flexibility and variation for creating a diverse series of page layouts for narrative and visual content while still maintaining a unified visual voice.

The size and proportion of a module can be determined by the width and depth of an average paragraph of continuous narrative text in a given type style and type size. Its proportion can be either vertical or horizontal and relates to the proportion or orientation of the images being used in a compositional layout.

When evaluating and finalizing these two primary factors for a modular grid, you also need to simultaneously define margin and gutter proportions and dimensions so that you end up with a fully integral page grid.

Modular grids are best suited for complex, multifaceted narrative and visual content that requires varying sizes and levels of importance to information. While this grid type is mostly used in newspapers, event calendars and programs, and data visualization charts and tables, it can also be effective in publications and websites where a strong sense of visual order and rationality is needed.

The genesis of modular grid systems was as a direct extension of the rational design tenets and principles of the Bauhaus and the International Typographic Style during the 1950s which celebrated objectivity, order, and the principle that “form follows function.”

Modular Grid

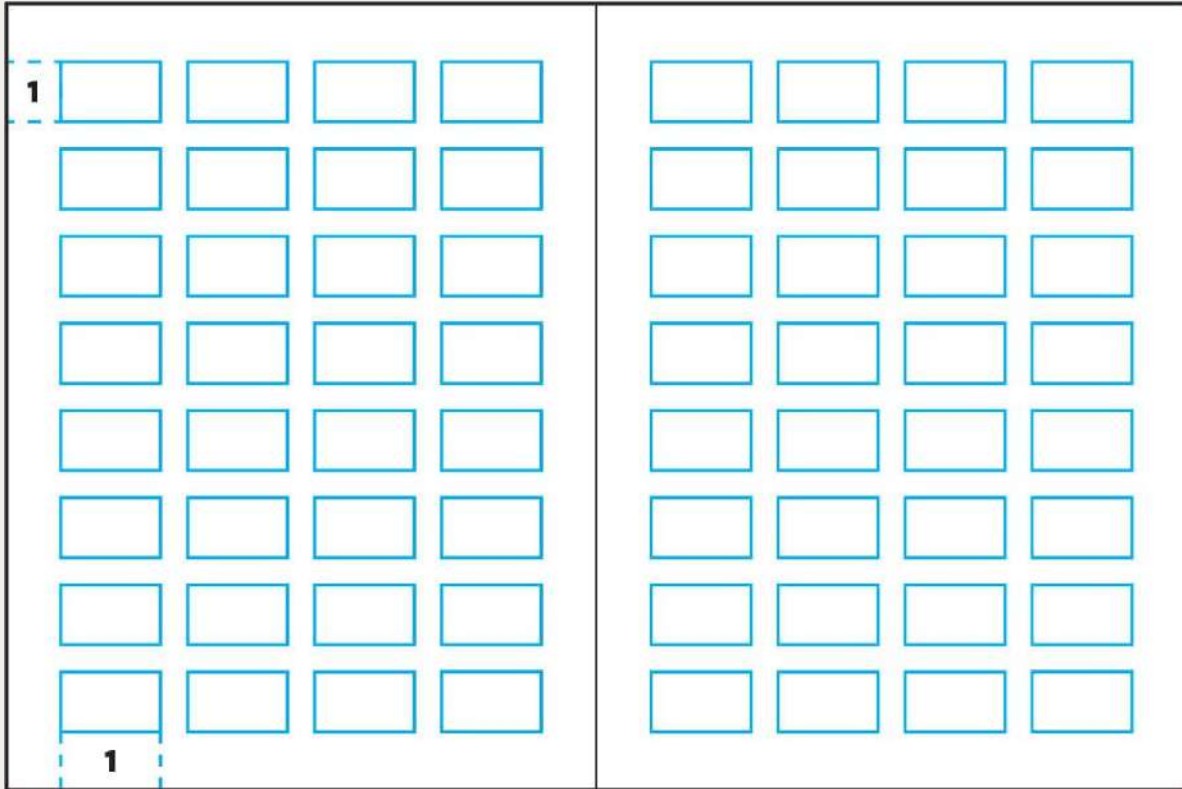

FULLY INTEGRAL MODULAR GRID

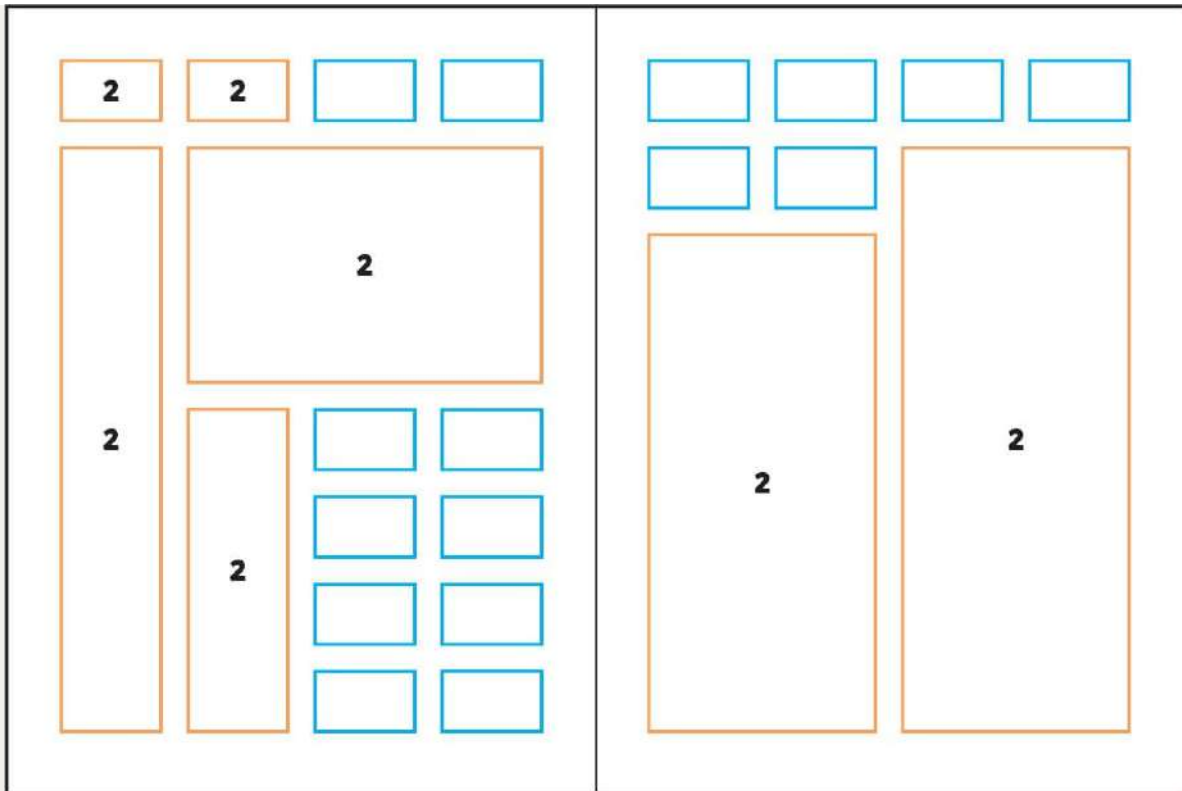

MODULAR GRID WITH ACTIVATED MODULES

GRID CHARACTERISTICS

1. Integral Grid

Gutter and margin proportions and dimensions are designed to be integral to the page; the grid pictured to the left terminates on a half module at the outer margins and a full module at the bottom margin.

2. Activated Modules

Modules can be activated individually or grouped together as spatial zones to be utilized for multifaceted narrative visual content that requires varying sizes.

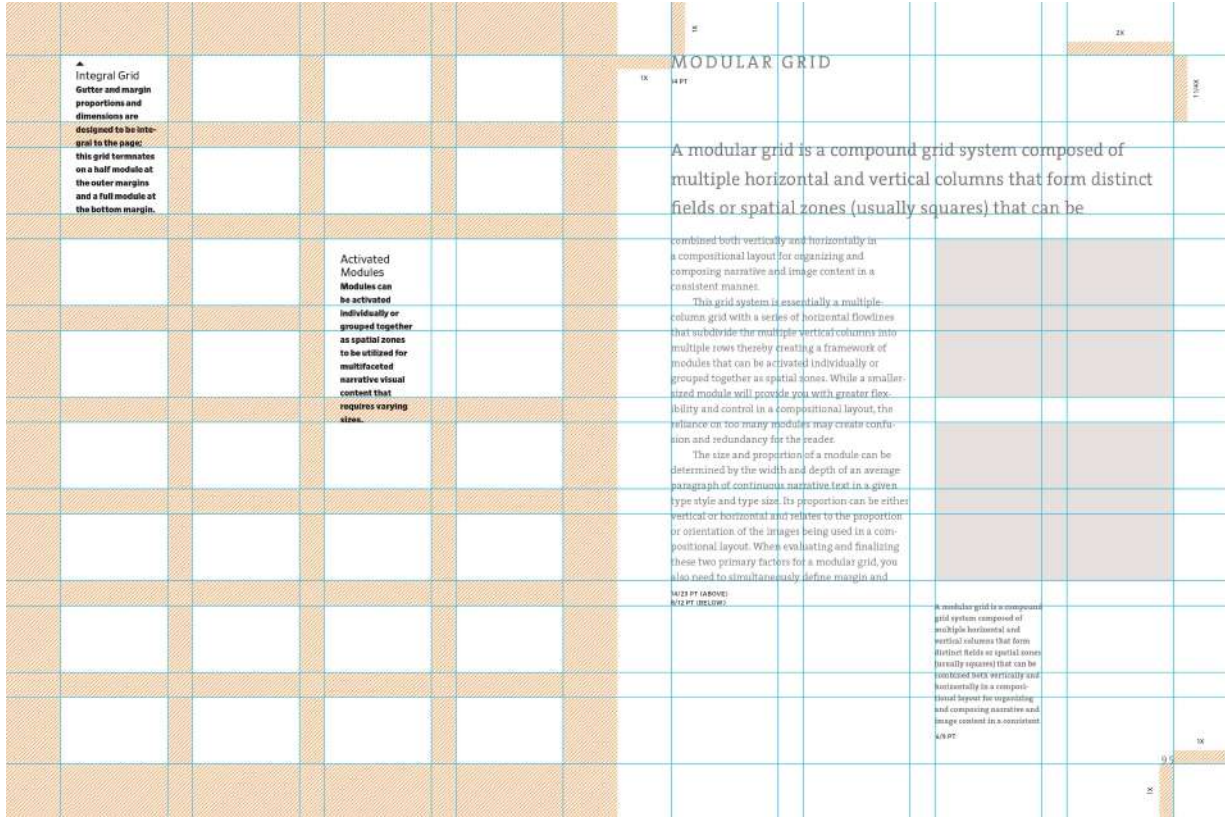

Asymmetrical Grid

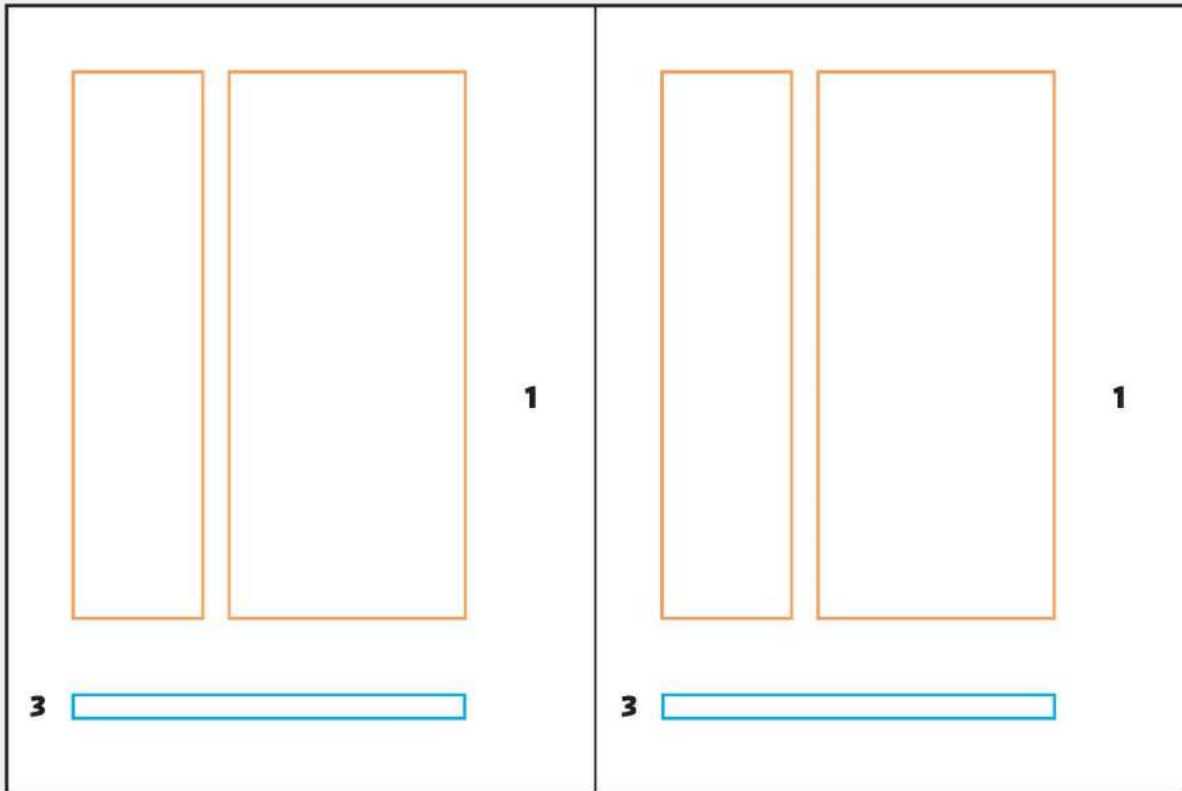

COLUMNAR

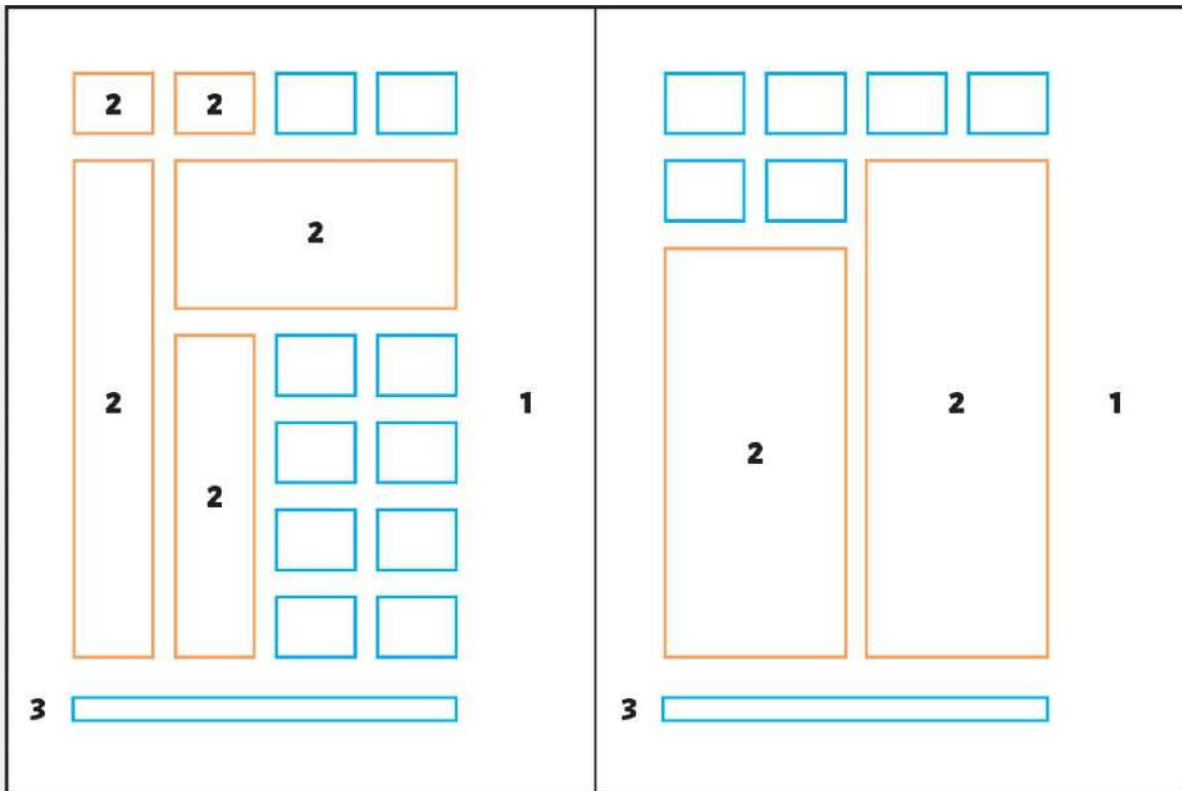

MODULAR

GRID CHARACTERISTICS

1. Asymmetrical

An asymmetrical grid in which the recto and verso pages of a compositional layout are not the same and introduce a bias toward the left page.

2. Activated Modules

Modules can be activated individually or grouped together as spatial zones to be utilized for multifaceted narrative visual content that requires varying sizes.

3. Secondary

Secondary elements may include headers or footers, chapter or section titles, and folios or page numbers.

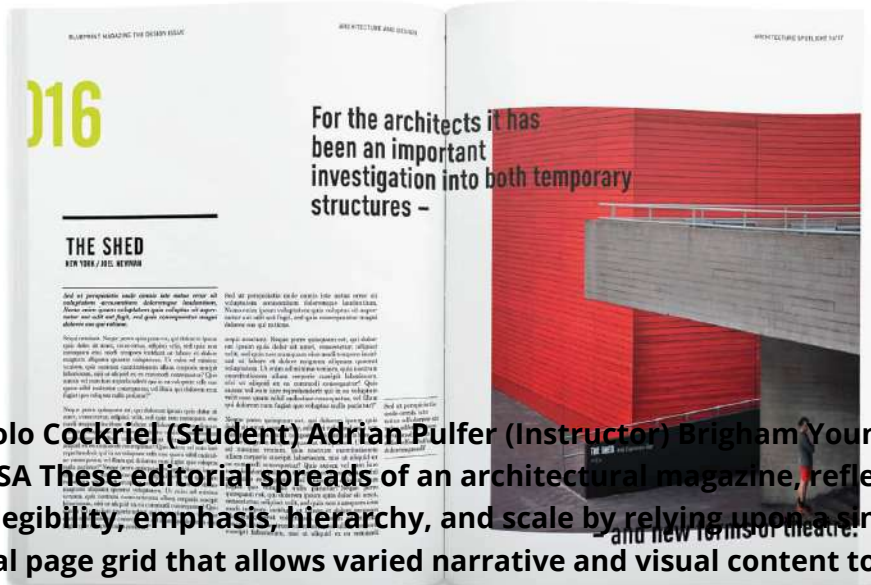

Blueprint Paolo Cockriel (Student) Adrian Pulfer (Instructor) Brigham Young University Provo, UT, USA These editorial spreads of an architectural magazine, reflect optimum readability, legibility, emphasis, hierarchy, and scale by relying upon a singular asymmetrical page grid that allows varied narrative and visual content to be treated in a meaningful and accessible manner for the reader. Varied content includes large-scale typography, project photography, architectural drawings, pull-quotes, captions, header, footers, and narrative text.

Asymmetrical (Columnar, Modular)

An asymmetrical grid is a system in which the recto and verso pages of a compositional layout are not the same and typically introduce a bias toward one page or the other (usually the left), imparting an asymmetrical, or imbalanced, visual appearance to a page spread.

For example, an asymmetrical grid can be composed of four (4) text columns —three (3) columns of the same width and one column that is narrower than the

others, which results in a bias toward one side of the page, traditionally the left-hand or verso page. This atypical column can be activated with supporting information relating to narrative text in the adjacent columns such as captions, footnotes, spot illustrations, and other related marginalia.



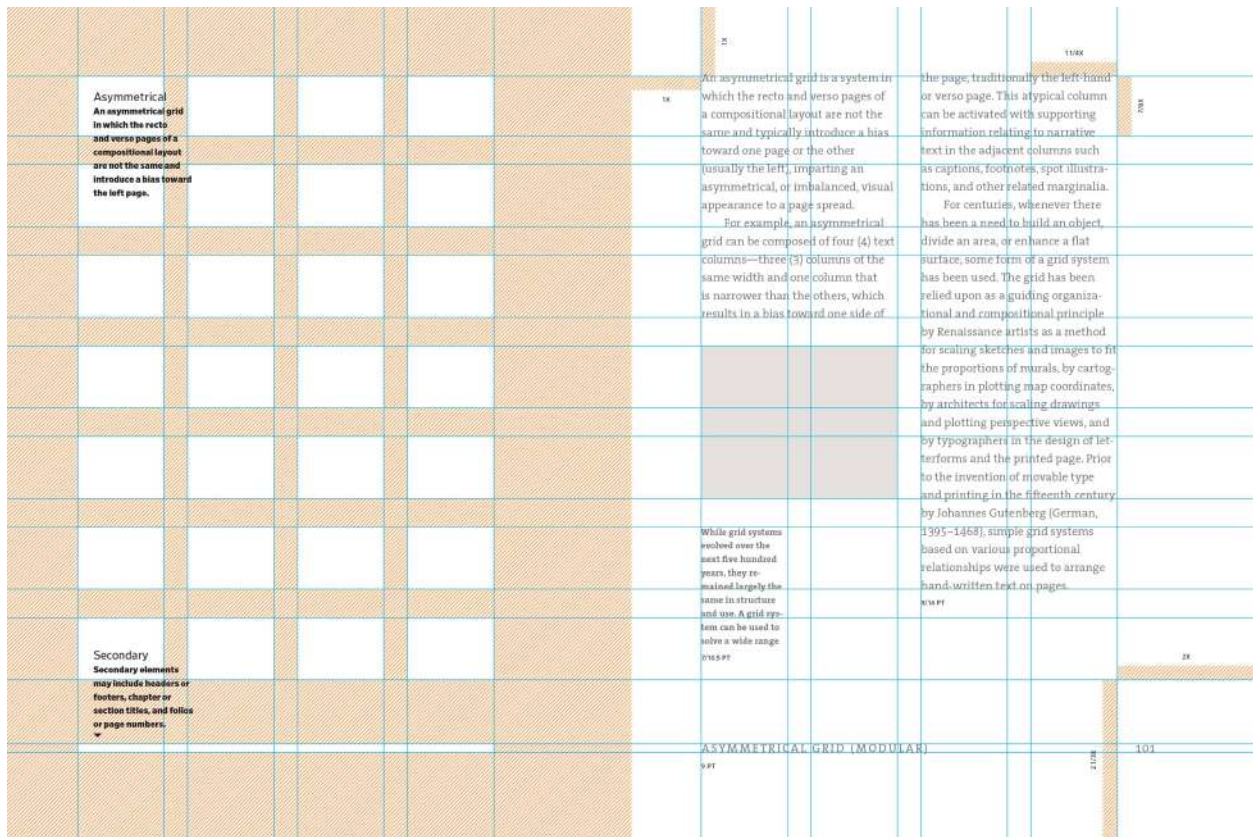

Baseline

A baseline grid is an essential and integral element in any effective grid system and is comprised of a series of equally spaced, parallel baselines for the placement of continuous narrative text, largerscale type, and related visual elements. It is typically developed for a specific type size and leading.

There are two primary advantages in using a baseline grid. The first is that it provides definitive size and location criteria for continuous narrative text, since it gives exact locations for each baseline of text. The second is that it allows continuous narrative text in different columns or on different pages to align, irrespective of type size.

A baseline grid can also accommodate different type sizes that are based on a multiple of its baseline intervals. For example, a 12-point baseline grid will accommodate 12, 24, 36, 48, 60, and 72-point type, as well as smaller type sizes such as 8 and 10-point type.

A grid system of baselines is a substructure that works with any of the other grid systems referenced in this section. It is an alignment framework composed of equally spaced baselines for all type elements in a compositional layout, and it is based on the size and leading of the type being used. In multicolumn compositional layouts, it further ensures that there is one consistent alignment

compositional layouts, it further ensures that there is one consistent alignment point for all type across gutters.

With a baseline grid, the decision-making process can be streamlined when all of its typographic and mathematical relationships are accurately defined beforehand. For example, the baseline grid system used in this volume is a 9-point type size with a baseline leading of 14-point. Based on these two point-size specifications, the sizes of all other typographic elements, such as headers, footers, drop caps, and captions are also defined. If a header is 36-point that means that this typographic information would occupy three baselines that equal 36 points (i. e. 3-point x 12 points = 36 points).

Leading will also influence the size of a baseline grid's vertical divisions, either with flowlines or modules. For optimum integration, a baseline grid's modules should be divisible by baseline increments. For example, if the type size being used is 9-point with 14-point leading and your modules are not divisible by 7, then you will have additional white space located at the bottom of each module, which will create an inconsistent and unresolved appearance in your layout.

Remember, in most situations you will be using more than one type size for any compositional layout; therefore, it is beneficial to further ensure that all typographic elements are related in size and leading. This will not only further guarantee that all text columns begin and end in a consistent and aligned manner, but it will also impart a more integrated and unified end result to your compositional layout.

Another advantage to utilizing a baseline grid relates to the size and placement of images. Image size and placement can be defined by their placement and position to an x-height (the height of the lowercase letters such as x) and baseline of the nearest corresponding line in the text block, and can extend across text columns to maintain consistency and cohesiveness in a compositional layout.

Baseline Grid

1 A baseline grid is an essential and integral
2 element in any effective grid system and
3 is comprised of a series of equally spaced,
4 parallel baselines for the placement
5 of continuous narrative text, larger-scale
6 type, and related visual elements. It is
7 typically developed for a specific type size
8 and leading.

9 There are two primary advantages in
10 using a baseline grid. The first is that it
11 provides definitive size and location criteria
12 for continuous narrative text, since it gives
13 exact locations for each baseline of text.
14 The second is that it allows continuous
15 narrative text in different columns or on
16 different pages to align, irrespective of
17 type size.

18 A baseline grid can also accommodate
19 different type sizes that are based on a

GRID MODULE DIVISIBLE BY 9 BASELINES

9/14 PT

A baseline grid is an essential and integral element in any effective grid system and is comprised of a series of equally spaced, parallel baselines for the placement of continuous narrative text, larger-scale type, and related visual elements. It is typically developed for a

A baseline grid is an essential and integral element in any effective grid system and is comprised of a series of equally spaced, parallel baselines for the placement of continuous narrative text, larger-scale type, and

A baseline grid is an essential and integral element in any effective grid system and is comprised of a series of equally spaced, parallel baselines for the placement

7/14 PT

9/14 PT

11/14 PT

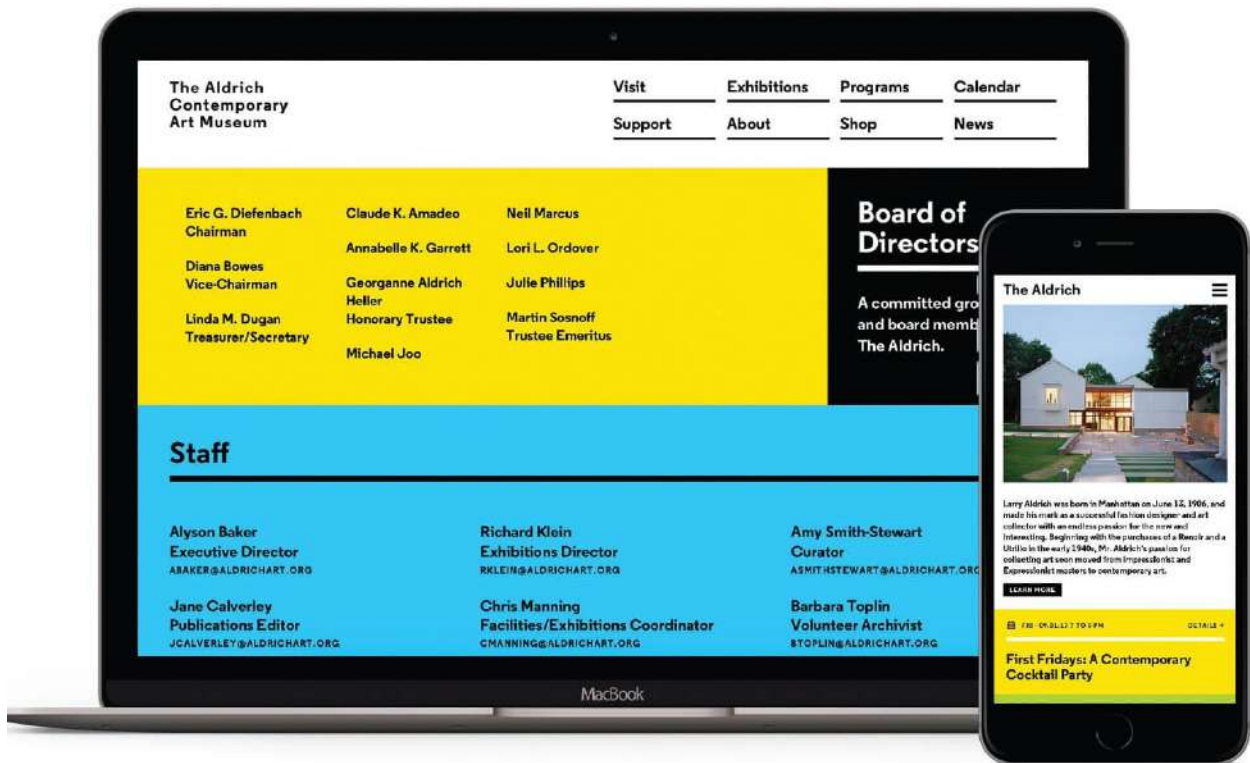

The Aldrich Contemporary Art Museum Sagmeister & Walsh New York, NY, USA A hierarchical columnar grid provides clear organizational and compositional diversity, as well as a fluid and organic approach, for the navigational, informational, and

photographic components of dynamic content for this contemporary art museum website.

Hierarchical

A hierarchical grid system is composed of a system of alignments and zones for text and images that varies from page to page, with its column width and proportion directly derived from diverse visual and narrative content.

This type of grid system has proven to be a very effective solution for a graphic designer when the content they are working with does not conform to the rigorous structure and regimented hierarchy of other grid systems. A hierarchical grid, while not appearing grid-like, provides a fluid and organic approach to determining the organization and hierarchy of narrative and visual content.

With any grid system, you need to undertake a thorough and in-depth review of all content. When you are fully versed and intimate with the content, any grid system you utilize will be better served. This is an essential initial task you need to undertake prior to conceptualizing and finalizing a hierarchical grid so that it meets all of your informational and communication needs. This type of grid system is well suited to project types such as packaging, promotional posters, and websites.

Website pages typically employ hierarchical grids, given that their column widths, as well as the spatial intervals between them, vary. This is driven by a website's dynamic content, with the resizing of the browser window requiring that maximum flexibility is achieved. These layout characteristics cannot be met with most regimented and rigorous grid systems; however, a hierarchical grid system meets these layout requirements.

Hierarchical Grid

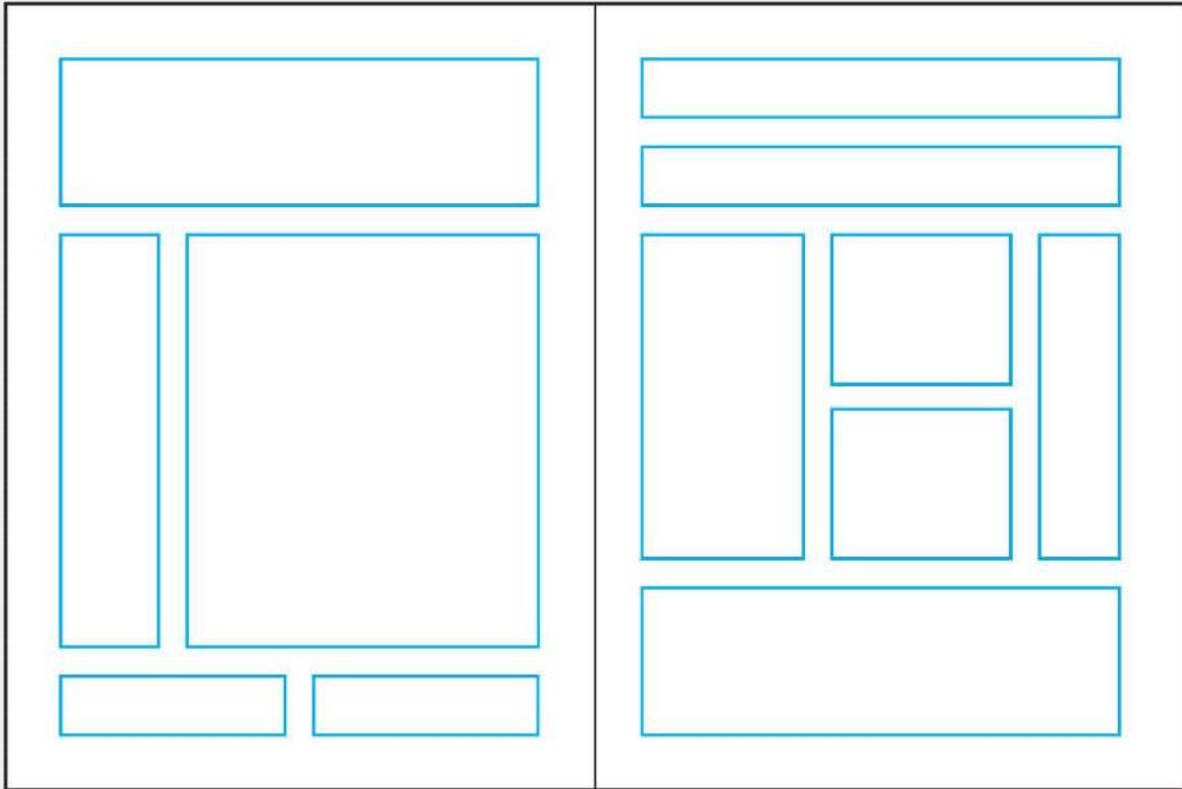

HIERARCHICAL GRID MODULES 1

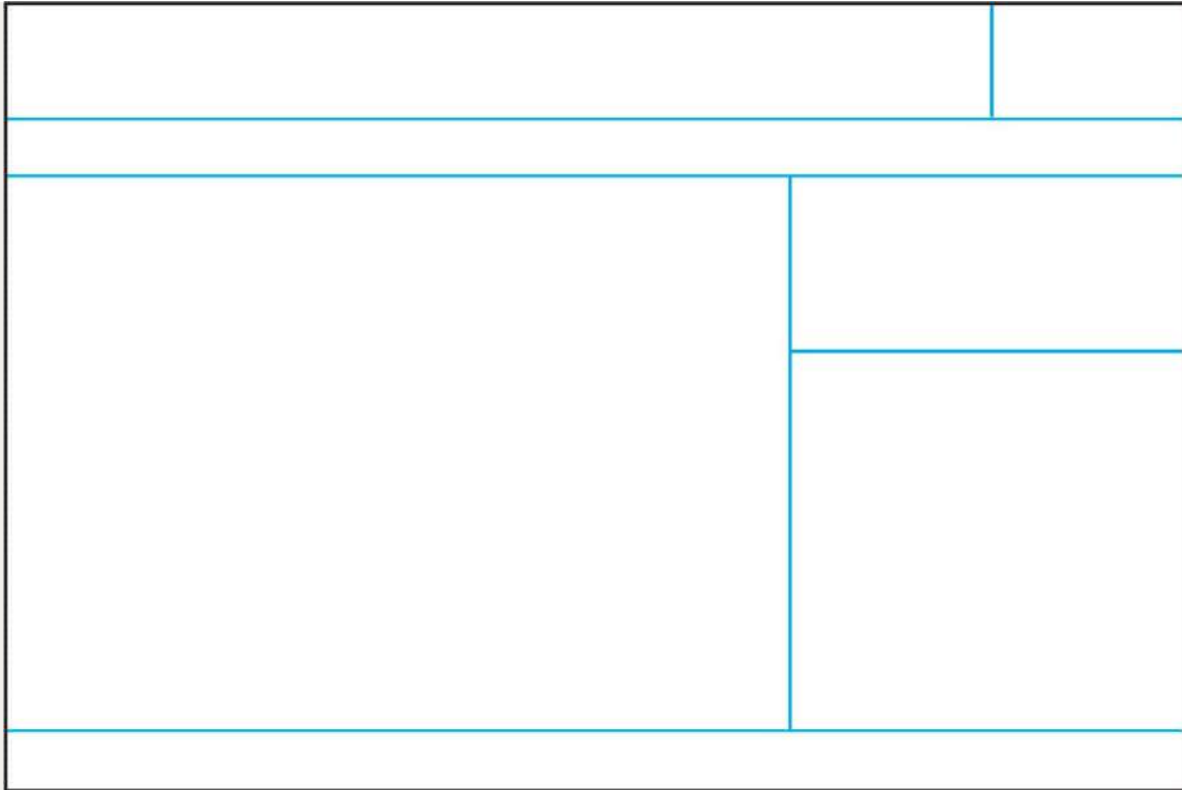

HIERARCHICAL GRID MODULES 2

GRID CHARACTERISTICS

Fluid/Organic

Hierarchical grids provide a fluid and organic approach to determining the organization and hierarchy of narrative and visual content by creating a system of alignments and zones for text and images that vary in size.

	18			
	19	<h2>HIERARCHICAL GRID</h2> <p>13.5 PT</p>		
		<p>A hierarchical grid system is composed of a system of alignments and zones for text and images that varies from page to page, with its column width and proportion directly derived from diverse visual and</p> <p>6/14 PT</p>		<ul style="list-style-type: none"> - fluid - organic - diverse
<p>Fluid/Organic Hierarchical grids provide a fluid and organic approach to determining the organization and hierarchy of narrative and visual content by creating a system of alignments and zones for text and images that vary in size.</p>		<p>This type of grid system has proven to be a very effective solution for a graphic designer when the content they are working with does not conform to the rigorous structure and regimented hierarchy of other grid systems. A hierarchical grid, while not appearing gridlike, provides a fluid and organic approach to determining the organization and hierarchy of narrative and visual content.</p> <p>With any grid system, you need to undertake a thorough and in-depth review of all content. When you are fully versed and intimate with the content,</p> <p>5/14 PT</p>		<ul style="list-style-type: none"> - variable - organized - versatile - dynamic <p>13.5/23 PT</p>
		<p>any grid system you utilize will be better served. This is an essential initial task you need to undertake prior to conceptualizing and finalizing a hierarchical grid so that it meets all of your informational and communication needs.</p> <p>13.5/23 PT</p>		
	109			<p>14</p> <p>15</p>

Marber Grid

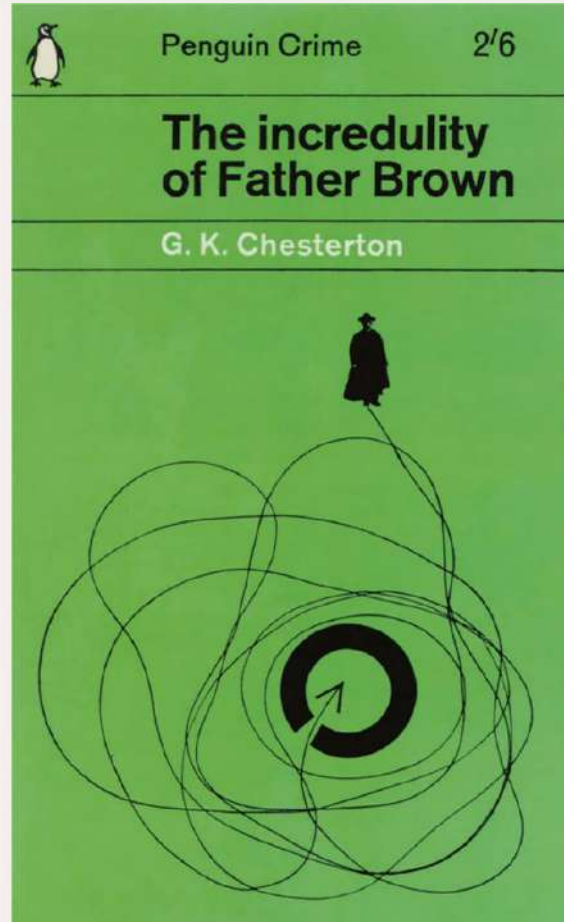
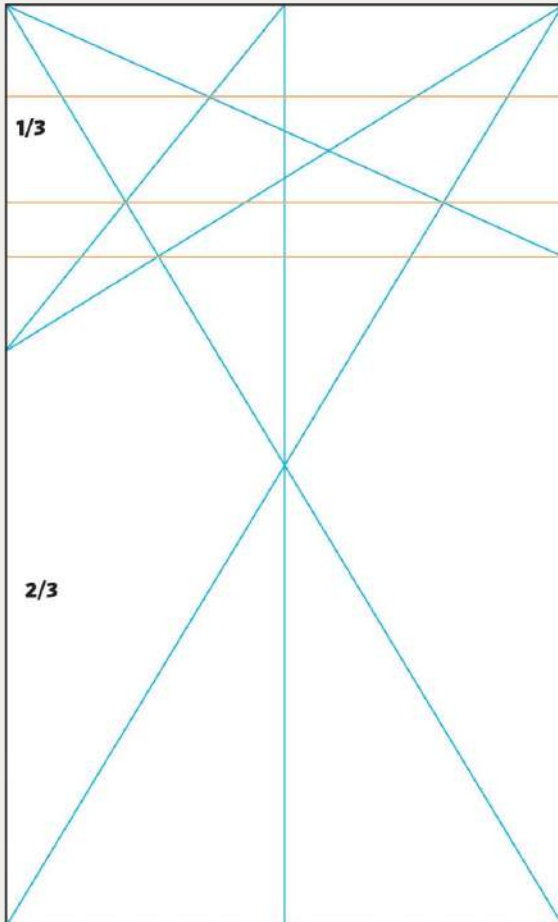

GRID CHARACTERISTICS

Organization/Zones

A methodical analysis of the compositional layout requirements produced a grid divided into thirds. Colophon, name, price, title, and author's name occupy the upper third with the lower two thirds for cover art.

Marber

In 1961, graphic designer Romek Marber (Polish, b. 1925) developed an organizational and compositional grid for Penguin Books that became one of the most innovative and recognized grid systems introduced in the latter part of the twentieth century.

Initially, Penguin art director Germano Facetti (Italian, 1926–2006) commissioned Marber to design book covers for Simeon Potter’s *Language in the Modern World* and *Our Language*. Following this commission, Facetti asked Marber and his colleagues, graphic designers Derek Birdsall (British, b. 1934) and John Sewell (British, 1926–1981) to develop a new approach for their series of crime fiction novels, which had not undergone any design refinements or changes since introduced twenty-five years earlier. It was with this commission that he started to methodically analyze the compositional layout requirements for this Penguin book series.

Marber’s new approach for the series’ covers retained the horizontal banding of the previous Penguin design standards, as well as the predominant green color of the series, but allowed the cover image to occupy over two-thirds of the cover itself. The title section located at the upper third of the cover is organized in three horizontal bands carrying the series colophon, name, price, title, author’s name—all flush left. By organizing this information together in the upper third of the grid, Marber created a more prominent live area for cover art, thereby capturing a reader’s attention and making a stronger visual “sell” of each Penguin title.

Marber’s innovative approach to a book cover’s compositional layout ultimately gave the entire range of Penguin Books a distinctive visual brand that remained effective and unique for the next two decades.

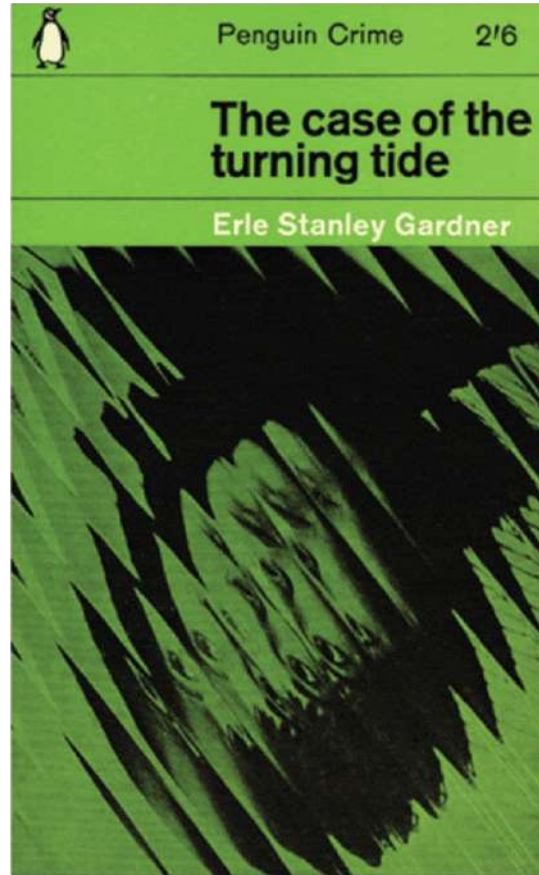
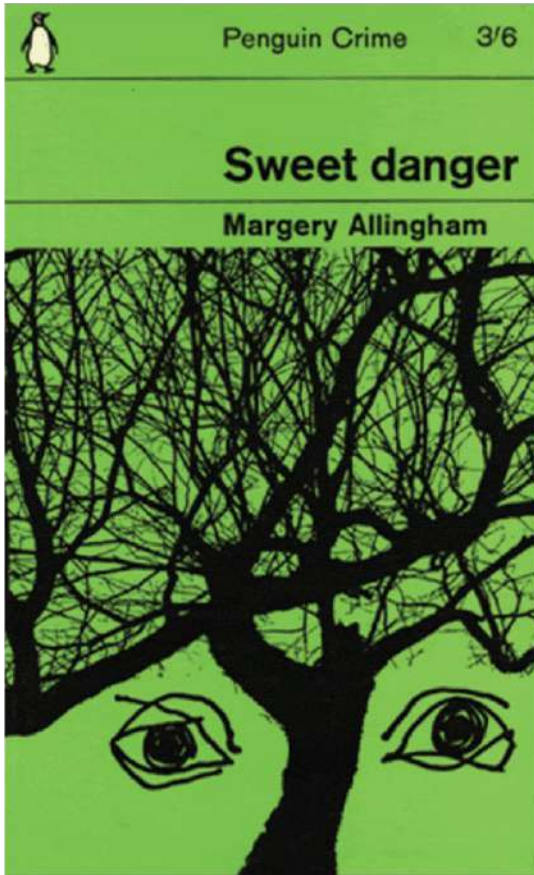

Images: ©Penguin Books Ltd.

Penguin Crime Romek Marber London, UK These examples of an extensive series of book covers reflect a unique approach to compositional grid systems with the upper third of the grid used solely for the book's colophon, title, and author's name and the lower two-thirds activated with a diverse selection of cover art. Color and typographic design standards are additional unifying elements of the series.

McGILL UNIVERSITY
SCHOOL OF ARCHITECTURE
MASTER OF
ARCHITECTURE
PROFESSIONAL PROGRAM 2014

FINANCE
REVIEWS
2014

McGILL UNIVERSITY
SCHOOL OF ARCHITECTURE
MASTER OF ARCHITECTURE
PROFESSIONAL PROGRAM 2014

FINANCE
REVIEWS
2014

McGILL UNIVERSITY
SCHOOL OF ARCHITECTURE
MASTER OF ARCHITECTURE
PROFESSIONAL PROGRAM 2014

GROUND
FLOOR
2014

McGILL UNIVERSITY
SCHOOL OF ARCHITECTURE
MASTER OF ARCHITECTURE
PROFESSIONAL PROGRAM 2014

GROUND
FLOOR
2014



McGill University School of Architecture Professional Program 2014 Atelier Pastille Rose Montréal, QC, CA A consistent set of specific grid elements—margins, flowlines, and gutters—are used in this well-integrated compound grid for a dual function poster and brochure promoting professional programs. This duality is further reinforced by a change in axis and orientation, as well as the use of a flush left alignment, for both sizes of typographic information.

Compound

Compound grids are created by the integration of two or more multiple-column grid systems into one organized, cohesive structure.

When you utilize a compound grid for your work, you further guarantee a varied but related visual rhythm and pacing to your compositional layouts. This can be achieved by maintaining a consistent set of specific grid elements—

can be achieved by maintaining a consistent set of specific grid elements— margins, flowlines, and gutters— for all grid systems used in your compound grid structure. By relying on common visual denominators among the varied grid structures used, you further reinforce a clear and seamless experience for the reader.

For example, the example shown is a two-column grid superimposed over a three-column grid with common or shared elements. This provides you with an increased number of layout options since you can divide the page in either proportion.



Compound Grid

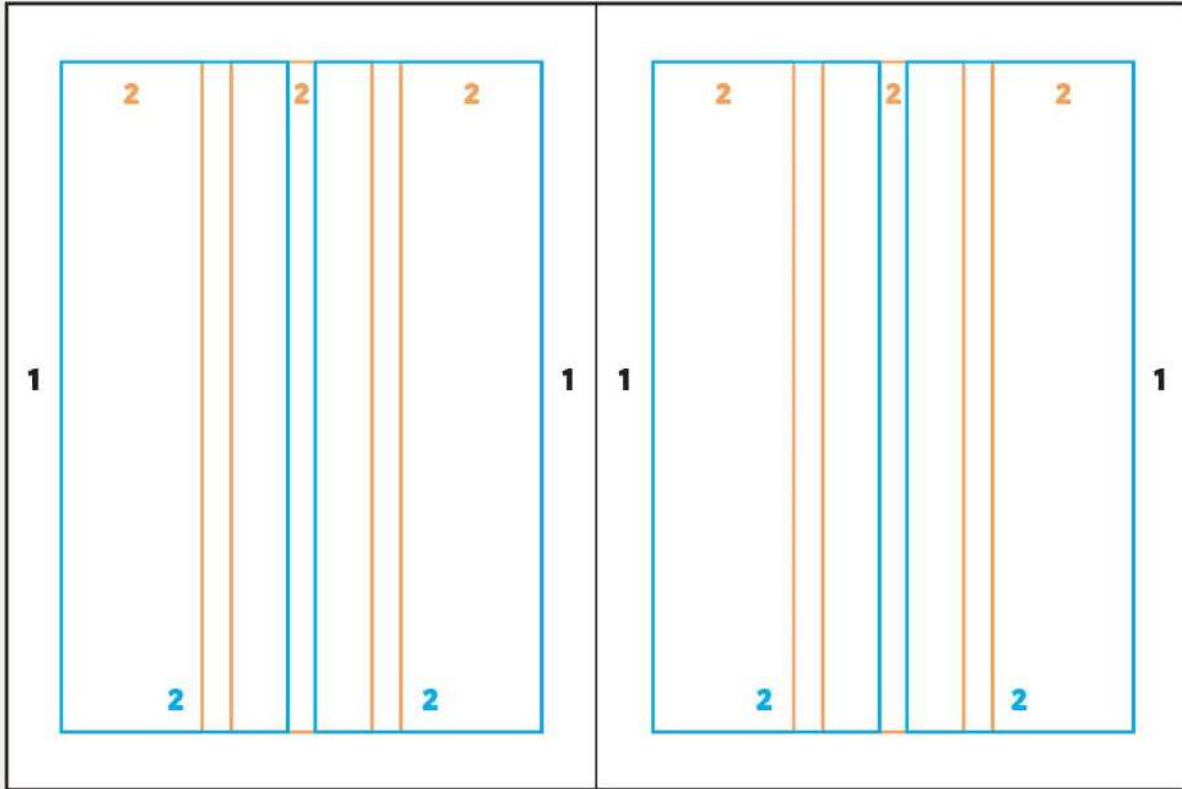

TWO/THREE COLUMN COMPOUND GRID

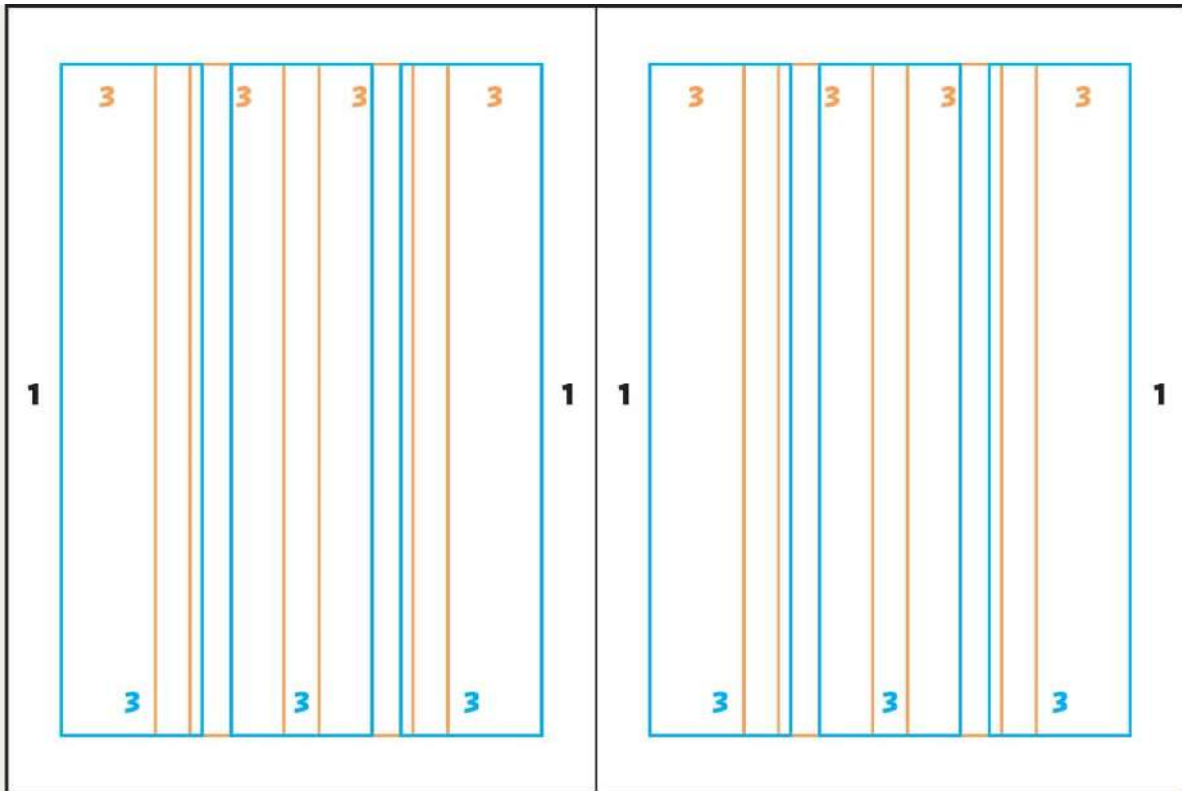

THREE/FOUR COLUMN COMPOUND GRID

GRID CHARACTERISTICS

1. Consistent Grid Elements

Varied but related visual rhythm and pacing can be achieved by maintaining a consistent set of specific grid elements—margins, flowlines, and gutters.

2. Two-Column/Three-Column Grid

A two-column grid is superimposed over a three-column grid; both grids have a consistent set of gutters.

3. Three-Column/Four-Column Grid

A three-column grid is superimposed over a four-column grid; both grids have a consistent set of gutters.

<p>Two-Column/ Three-Column Grid A two-column grid is superimposed over a three-column grid; both grids have a consistent set of gutters.</p>	<p>18</p>	<p>Consistent Grid Elements Varied but related visual rhythm and pacing can be achieved by maintaining a consistent set of specific grid elements—margins, flowlines, and gutters.</p>	<p>Compound grids are created by the integration of two or more multiple-column grid systems into one organized, cohesive structure.</p> <p>When you utilize a compound grid for your work, you further guarantee a varied but related visual rhythm and pacing for your compositional layouts. This can be achieved by maintaining a consistent set of specific grid elements—margins, flowlines, and gutters—for all grid systems used in your compound grid structure. By relying on common visual denominators among the varied grid structures used, you further reinforce a clear and seamless experience for the reader.</p>	<p>For example, the example shown is a two-column grid superimposed over a three-column grid with common or shared elements. This provides you with an increased number of layout options since you can divide the page in either proportion.</p> <p>For centuries, whenever there has been a need to build an object, divide an area, or enhance a flat surface, some form of a grid system has been used. The grid has been relied upon as a guiding organizational and compositional principle by Renaissance artists as a method for scaling sketches and images, by cartographers in plotting</p>	
<p>layout of newspapers, magazines, books, annual reports, brochures, catalogs, sign systems, corporate identity and branding programs, and websites.</p> <p>As a flexible compositional tool, a grid can assist you in creating either static, symmetrical layouts, or active, asymmetrical ones. The basic construction of any grid can be orthogonal, angular, irregular, or circular. It can be an invisible and functional layer of a compositional layout or it can be an obvious and dynamic visual element.</p> <p>A graphic designer should always consider the structure of a grid system based on their thorough analysis of the visual and narrative content to be used. This will allow a considerable degree of flexibility when composing and arranging disparate elements, such as text and images, on a grid and ultimately the compositional page layout.</p> <p>7/10.75 PT (ABOVE) 8/14 PT (BELOW) 9 PT (COMMON)</p>	<p>19</p>	<p>be it two-dimensional, three-dimensional, or virtual.</p> <p>A grid system can be visible or invisible; an implied framework or an obvious design element. It is also an essential design principle for organizing and presenting complex, multifaceted information in a systematic manner. Publications, websites, sign systems, advertising campaigns, and corporate communications are all comprised of multiple pages, each requiring a slightly different compositional layout due to their varied content.</p> <p>If a grid system is well planned and conceived, it provides you with an efficient way in which to create multiple compositional layouts while maintaining visual consistency and cohesiveness in a book, publication, or website.</p> <p>The development of the grid has been an evolutionary process. No one artist or graphic</p>	<p>map coordinates, by architects for scaling drawings and plotting perspective views, and by typographers in the design of letterforms and the printed page. Prior to the invention of movable type and printing in the fifteenth century by Johannes Gutenberg (German, 1395–1468), simple grid systems based on various proportional relationships were used to arrange hand-written text on pages. While grid systems evolved over the next five hundred years, they remained largely the same in structure and use.</p> <p>A grid system can be used to solve a wide range of design problems and is an effective organizational and compositional tool for the</p>	<p>19</p>	
<p>COMPOUND GRID</p>		<p>20</p>	<p>20</p>	<p>20</p>	<p>20</p>

Test your Knowledge

1. What is the simplest type of grid system, derived from traditional written manuscripts of the early fourteenth and fifteenth centuries?
2. Which grid system is composed of a primary rectangular text area which is used to display extensive continuous text and whose left-and right-page text blocks mirror one another with a wider inner margin?
3. What is the most effective way of adding visual interest and variation to a compositional layout that uses a manuscript grid?
4. What are the primary visual characteristics of a symmetrical grid?
5. What is the term used to identify the left-hand page of a compositional layout or double-page spread?
6. What is the term used to identify the right-hand page of a compositional layout or double-page spread?
7. What are the primary visual characteristics of a single-column symmetrical grid?
8. What are the primary advantages of utilizing a double-or multiple-column symmetrical grid for compositional layouts?
9. What is an optimum measure or character count per text line for any given column width and line length for optimum readability and legibility?
10. What is an optimum measure or character count per text line for a multiple column width and line length for optimum readability and legibility?
11. What are the primary visual characteristics of a modular grid?

12. What is one method for determining the size and proportion of a module in a modular grid?
13. Identify the design school and prominent style in which the modular grid had its genesis?
14. What are the primary visual characteristics of an asymmetrical grid?
15. What are the primary visual characteristics of a baseline grid?
16. What are the two (2) primary advantages of using a baseline grid in a compositional layout?
17. What is the method for defining the size and placement of images in a baseline grid?
18. What are the primary visual characteristics of a hierarchical grid?
19. What are the primary visual characteristics of a Marber grid?
20. What are the primary visual characteristics of a compound grid?

For answers to Test your Knowledge, see [here](#).



Section 4

Compositional Principles

For any graphic designer to communicate effectively and memorably in visual terms, they have to first gain a complete understanding of the fundamental principles of compositional layout. This section provides you with an in-depth understanding of these fundamental principles—what they are, why they are important, and how to use them effectively.

The fundamental principles of compositional layout are the foundations that enable you to use visual elements in the most appropriate and effective manner in creating meaningful and communicative graphic design. Elements are the “what” of a graphic designer’s visual language and principles are the “how.” When carefully considered and utilized together, they allow you to “speak” in an accessible, universal, visual language.

We are taught at an early age about the principles of written and verbal communications; however, the same cannot be said for visual communications. As we were taught the basics of spelling, grammar, and syntax, we can be taught the basic fundamentals of graphic design. The elements and principles of graphic design, such as form, shape, color, proportion, balance, movement, symmetry, asymmetry, tension, and contrast, are a graphic designer’s vocabulary for giving voice and, ultimately, meaning to any compositional layout.

Compositional layout, like written and verbal communications, involves a graphic designer’s analysis, planning, organizing, and ultimately problem-solving. When you write, or speak, you intuitively choose which words to use and how to use them together to effectively communicate your message. In graphic design, the same end result can be achieved, but, you need to be just as intuitive with its elements and principles.

Throughout your education and career, these basic tenets of visual structure and organization are constantly referred to for inspiration, ideas, and as reminders of how they provide the basis for designing meaningful, memorable, and communicative work. Without a reliance on these fundamentals, your work will be ineffective, non-communicative, and will not “speak” to any audience.

Balance

Balance is defined as a visually pleasing integration of elements or a harmonious

or satisfying arrangement or proportion of parts or elements in a compositional layout. It occurs when visual elements within a compositional layout are equally distributed and arranged to communicate a feeling of stability, harmony, and equilibrium. The visual and compositional principle of balance can be described as formal and symmetrical, dynamic and asymmetrical, or radial.

Our response to balance is intuitively linked to taking our first steps as human beings. It is that essential need to stand, walk, and run that also relates to our fundamental, primal need to prefer balance in our lives, as well as in any compositional layout.

Balance is achieved in a composition by arranging dissimilar elements with different visual characteristics. There are three distinct types of visual balance:

Formal Balance or Symmetry

Formal balance or symmetry is the easiest type of balance you can achieve in a compositional layout. It is used extensively in architecture, since it inherently conveys stability and permanence, and automatically provides a singular focus to whatever is placed in the center of a composition. It is also based on a mirror image; if you draw a line down the center of a drawing of a gothic cathedral, elements on either side will be identical to one another and appear as a mirror image.

You can create formal balance when visual elements are arranged equally on both sides of a compositional layout and appear stable or static. Here, the two sides of the composition are identical and reflect one another.

Contemporary Influence:

Jacqueline Casey and the Art of Visual Balance

In 1955, Jacqueline Casey (American, 1927–1991) started her professional career as a graphic designer when she joined the Office of Publications (Design Services Office) at the Massachusetts Institute of Technology (MIT) in Cambridge, under the design direction of fellow classmate Muriel Cooper (American, 1925–1994). When Cooper joined MIT's faculty in 1972, Casey took over as director and created a series of iconic promotional posters to publicize MIT events and exhibitions. For over three decades, she was a woman working in a man's world, not only in the MIT Office of Publications but also in the environs of the entire MIT community that served as her sole client.



Casey worked at MIT for over thirty years, during which time she developed a unique design philosophy, a memorable body of work, and a thought-provoking visual brand for the Institute.

In F.H.K. Henrion's (German, 1914–1990) 1983 book *Top Graphic Design*, Casey said, "Being a graphic designer at MIT continues to be a fascinating experience for me. My job is a constant learning experience. While MIT has its roots in tradition, the University represents all that is experimental, exciting, and future-oriented."

Casey's work was influenced by the modernist movement, the International Style, and by designers such as Karl Gertsner (Swiss, 1930–2017), Armin Hofmann (Swiss, b. 1920), and Josef Müller-Brockmann (Swiss, 1914–1996). She developed a visual language that was purely her own but was strongly connected to the tenets of proportion, grid, and the use of European sans serif typography.

Balance also played a fundamental role in all of Casey's posters. Each of her posters contains a singular focal point, or primary visual element, that immediately attracts the viewer, such as the *Charles Ross: Light Placed* poster (1977; see above).

Casey's work engaged the intellect and curiosity of her academic audience

because it was a seamless, balanced integration of type and image, as well as a memorable and powerful vehicle for storytelling.

Image: ©MIT Museum.

Balance

Balance occurs when visual elements in a compositional layout are equally distributed and arranged to communicate a feeling of stability, harmony, and equilibrium. This compositional principle can be described as formal balance or symmetrical, dynamic balance or asymmetrical, or radial balance. Various degrees of visual balance can be achieved by relying upon contrast in color, value, shape, texture, weight, location, and direction to offset or emphasize visual elements in a layout.

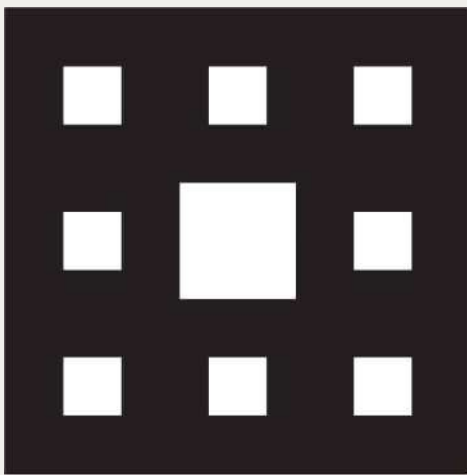

FORMAL BALANCE OR SYMMETRY

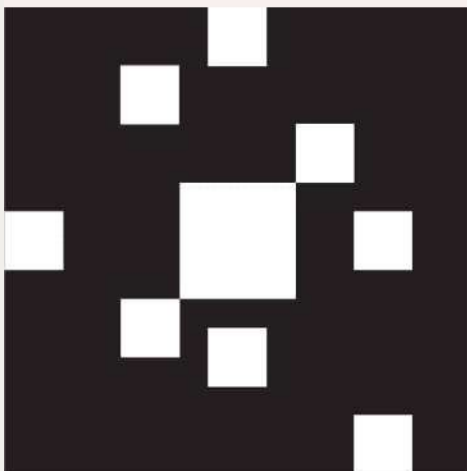
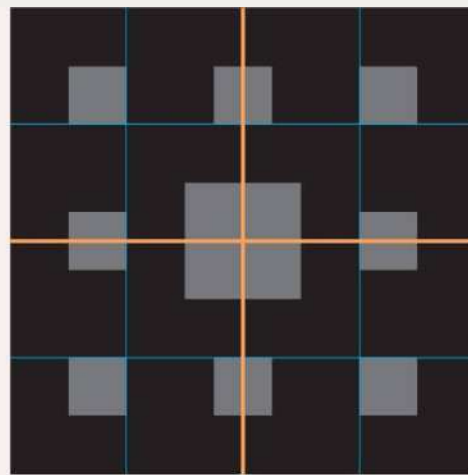

DYNAMIC BALANCE OR ASYMMETRY

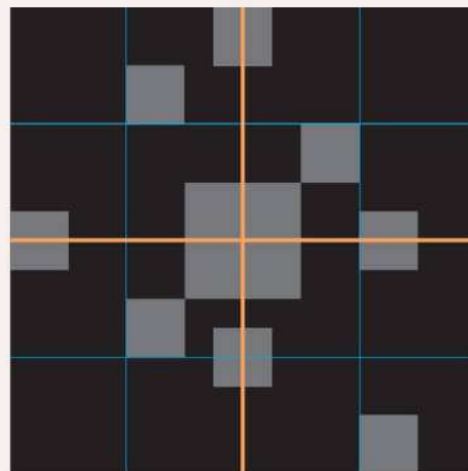

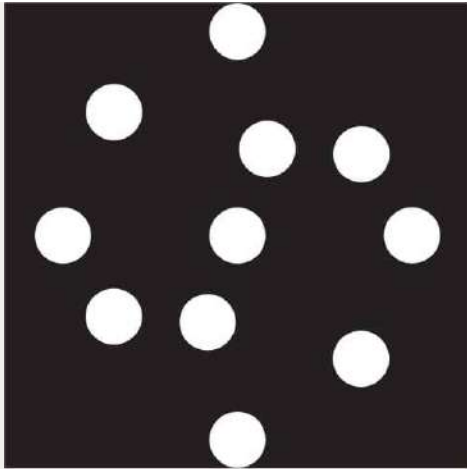

RADIAL BALANCE

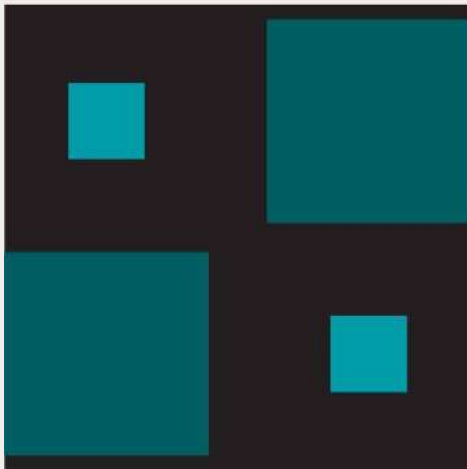
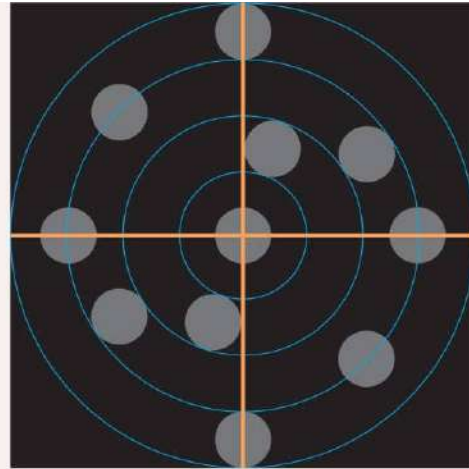

COLOR

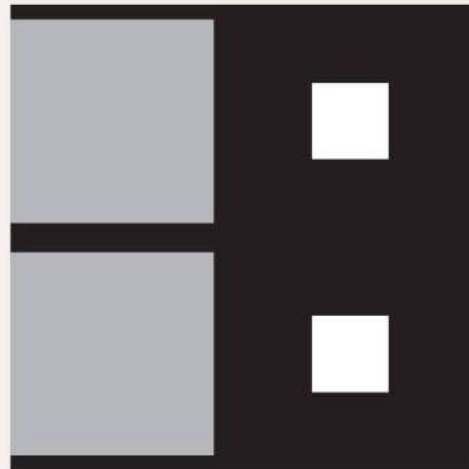

VALUE

Dynamic Balance or Asymmetry

Dynamic balance or asymmetry is more interesting and more difficult for you to achieve. It occurs when visual elements are arranged in a deliberately unequal manner in a compositional layout, and appearing random and dynamic. Here, the composition lacks balance and appears visually off-kilter.

Although dynamic balance has a more casual and less planned appearance, it requires careful planning and analysis to ensure that it always appears visually balanced.

Radial Balance

Radial balance is based on a circle and occurs when visual elements in a compositional layout radiate out from a central, common point in a circular direction and their visual weight is equally distributed. This type of balance

direction and their visual weight is equally distributed. This type of balance creates a strong focal point, always leading a reader's eye to the center of the composition. Stars, clocks, watch faces, the spokes of a wheel, and sunflowers are all prime examples of radial balance.

Degrees of Balance

A graphic designer can rely upon contrast in color, value, shape, texture, weight, location, and direction to offset or emphasize visual elements in any balanced compositional layout. You can create various degrees of visual balance in a compositional layout by relying upon a combination of the following design elements and principles:

Color

Color is one of the most powerful and communicative visual elements in a graphic designer's language. It affects all of us by providing visual energy and variation in what we see and experience on a daily basis. Color is used to attract attention, group disparate visual elements, and reinforce meaning. It can also immediately convey an attitude or emotion, provoke a response, create emphasis and variety, communicate a specific message, and further strengthen an established hierarchy in any compositional layout.

A reader's focus is always more drawn to color than a monochromatic or neutral composition. Color can be used to offset larger compositional elements that are neutral in color; therefore, your knowledge of color and the fundamental aspects of complementary and analogous colors is essential in influencing a balanced compositional layout.

Value

Value refers to the lightness or darkness of compositional elements. Black against white has a much stronger contrast or visual weight than gray against white; therefore, smaller-scale elements of high contrast can be used to balance larger-scale elements of low contrast.

Shape

From ancient glyphs to contemporary symbols, shape is one of the fundamental visual elements of a graphic designer's language. Shape is defined by boundary and mass and refers to a contour or an outline of a form. It is a two-dimensional plane that appears to be flat and is defined by an enclosing, contour line, as well as by color, value, texture, or type. It is the external outline of a plane that results from a line that starts at one point and continues back to its beginning, creating

an enclosed space or shape. It is composed of width and height, but never depth. A shape is a line with breadth.

Small, intricate shapes can balance larger, simpler shapes. Similarly, large uncluttered areas within a compositional layout that possess little or no detail can be balanced with small, irregular shapes, since a reader's eye is usually drawn to the more intricate shapes. Shapes can be geometric, organic, or random, and used to define compositional layouts, create patterns, and compose countless elements in a layout.

Texture

Texture is defined as the look and feel of any surface. It is the surface quality of an object, be it smooth, rough, soft, or hard, and is essentially a visual effect that adds richness and dimension to any compositional layout. It can be seen and experienced by human touch or interpreted tactilely by visual means. Texture can be described as flat, shiny, glossy, glittery, velvety, wet, feathery, gooey, furry, sandy, leathery, cracked, prickly, abrasive, puffy, bumpy, corrugated, rusty, slimy, and so on.

Texture, along with other visual elements and principles defined here, can communicate a variety of different emotions, as well as enhance a broad range of messages, in any compositional layout. For example, rough textures are visually active and kinetic, while smooth textures are passive and calm. Smaller compositional areas in a layout, containing textures, such as variegated, irregular, or random linear nuances, can balance larger areas with smoother, innocuous textures.

Weight

The perceived weight of an element in any compositional layout contributes to its visual interest. For example, a visually heavier element has more visual interest than a visually lighter element of the same size.

Visual balance can be affected not only by the size of compositional elements, but also by their intrinsic value, such as lightness or darkness. This is also described as an element's visual weight. When compositional elements are of equal visual weight, they are in balance.

Location

A smaller element located farther away from the center of a compositional layout will balance a larger element that is located closer to its center.

Additionally, larger elements located on one side of a layout can be balanced by smaller elements located at the far end or the other side of a composition. This is

smaller elements located at the far end of the other side of a composition. This is also the basis for asymmetrical balance.

Direction

A reader's eye can be directed to a specific location in a compositional layout based on how its design elements are arranged. For example, if elements are oriented in a specific direction, a reader's eye will also be led in that same direction.

Visual balance is an essential requirement in all graphic design. Just as balance is a state of physical equilibrium where everything comes to a standstill, it is also a state of visual harmony, in which all characteristics of a compositional layout are mutually interconnected and interrelated.

Movement

Movement is defined as the act or process of moving, or a change of place, position, or effort. It can be actual or implied. In a painting or photograph, for example, movement refers to a representation or suggestion of motion. In sculpture, movement refers to implied motion, with the exception of mobiles and kinetic sculptures, which have actual motion.

In graphic design, movement apparent in a poster, book cover, or editorial spread, forces a reader's eyes to be in constant motion and brings to their attention one or more visual elements within the compositional layout. A reader's eyes may be led to the center of the composition because there is a bright color located there, and then to another location that contains typography functioning as a headline in a bold typeface. Here, your responsibility is to direct a reader's attention through a specific sequence of visual experiences, as opposed to randomly going from one element to another in a compositional layout.

The primary function of movement in graphic design is to guide a reader through and around a visual message. In a three-dimensional composition or space, you need to consider not only movement realized with light and color, but also the physical movement of a reader through, in, and around the environment.

Elements and Techniques

Movement in any compositional layout is realized and fully dependent upon combining the basic elements of graphic design, such as line, shape, form, and texture, to produce the look and feel of motion. They can create a collective sense of movement that causes a reader to move through an overall compositional layout or to focus on an isolated group of elements within a

compositional layout.

Visual techniques, such as repetition and rhythm, can be relied upon to enhance movement in a two-dimensional or three-dimensional layout. In many ways, these two visual techniques can be thought of as visual “music,” since they have a direct relationship to creating the “tempo” of any composition.

With the repetition of line, shape, form, and color, a visual sequence can be created to guide or “navigate” a reader along a specific visual path or sequence of events. A repetitive visual sequence in a compositional layout can be regular, irregular, gradual, or exaggerated in its visual character.

Other Considerations

Movement is not only critical to the compositional aspects of a singular layout; it is also a critical aspect in the construction and organization of any work comprising multiple images, pages, and frames such as books, magazines, motion graphics, websites, and electronic interfaces. In these examples, movement is used to enhance variation and change in visual and narrative content, as well as providing a variety of scales, tonal values, and textural variations from page to page, while maintaining a visual and structural cohesiveness in the overall work.

Real and true movement is only found in the real world. Movement in the visual world is only a representation of movement. In graphic design, movement can be either represented or the illusions of movement can be created. In many ways, movement is transparent in graphic design. It only exists in an implied sense through the arrangement and organization of elements of varying size, shape, form, color, texture, and contrast in a compositional layout.

Contemporary Influence:

Max Huber and the Visual Dynamics of Movement

Max Huber (Italian, 1919–1992) was one of the most significant graphic designers of the twentieth century and an influential figure in the history of graphic design.

He studied at the Kunstgewerbeschule in Zürich and worked as an art director, before moving to Milan in 1940, where he became art director of Studio Boggeri. Huber was also a member of the distinguished association of Swiss modernist artists, graphic designers, and architects called the Allianz, a group whose members included Jean Arp (French, 1886–1966), Max Bill (Swiss, 1908–1994), Le Corbusier (Swiss, 1887–1965), Paul Klee (Swiss, 1879–1940), Leo Leuppi (Swiss, 1893–1972), and Richard Paul Lohse (Swiss, 1902–1988).

In his early career, Huber was greatly influenced by the teachings of modernist masters such as Max Bill and László Moholy-Nagy (Hungarian, 1895–1946) and was therefore among the first designers in Italy to apply avant-garde principles and aesthetics to commercial graphic design such as in posters, jazz record album covers, and book covers.

One celebrated example of this modernist approach was Huber's memorable posters for the Monza races. Starting in 1928, Huber designed promotional posters and flyers for the Monza car races in Italy, mainly for the Grand Prix and the Lottery Race. This poster series illustrates how he approached bringing movement to two-dimensional compositions.

Huber's 1948 poster for the motor races at Monza incorporated illusions of visual perspective that reinforced a great sense of movement and speed—letterforms are disappearing into the distance and are in counterpoint to the arrows moving in a forward motion. Additionally, varied typographic sizes and vibrant transparent colors laid over one another provide exaggerated depth,



rhythm, and movement to the overall poster's composition. For example, the red-and-blue arrows give direction to the street. The type identifying the event, "Gran premio dell' Autodromo," rushes across the field of the poster with great visual speed, as if it transformed itself into one of the cars racing at that very moment.

This innovative poster illustrates architect and designer Ettore Sottsass's (Italian, 1917–2007) dictum of 1947: "one can state calmly that the people of Greece would never have existed without the sea, and that the sea is their great story. I believe our great story, by contrast, is speed (*velocità*)."

It is also important to note here that Huber created these dramatic and distorted visual effects with typography that was highly readable and impactful, and without the assistance of contemporary methods of photocomposition, digital composition, and image manipulation software.

Huber relied upon the basic tenets of perspective to imply distance, movement, depth, rhythm, and motion in a unique and memorable way. This poster is a classic visual representation that is simultaneously suggestive and powerful on the theme of movement. The Monza posters and flyers embody a joyfulness conveyed through the combination of vibrant colors, balanced lines, and oblique angles, all lending rhythm and spatial harmony to the composition. It is a choreographed composition of visually moving dynamics.

Image: ©Aoi Huber Kono.

Symmetry

Symmetry is a fundamental and timeless principle of visual perception. In graphic design, symmetry conveys order, balance, stability, and harmony. When visual elements are balanced or centered in a compositional layout, they are in a state of equilibrium, whereby all elements have equal weight. This result is identified as symmetry.

Symmetry is a compositional state in which visual elements are organized by a graphic designer on the central axis of a compositional layout (either its horizontal or vertical axis). A similar compositional state can be achieved when visual elements are organized in relation to each other's central axes.

Symmetrical compositions are static and stationary with the negative spaces around its elements or the contours of its elements located around the central axis of a compositional layout are all equal.

Symmetrical, or formal, balance is also known as bilateral symmetry. It is achieved by repeating the reverse of an image on the opposite side of a vertical axis, with each side becoming the mirror image of the other side. Symmetrical balance is considered formal, ordered, stable, and quiet.

Symmetry

When visual elements are balanced or centered in a compositional layout, they are in a state of equilibrium or symmetry. Symmetry in a compositional layout is achieved when visual elements are organized on a central axis (either its horizontal or vertical axis). A similar compositional layout can be achieved when visual elements are organized in relation to each other's central axes. Symmetrical layouts are static and stationary with the negative spaces around its elements or the contour of elements located around the central axis are all equal.

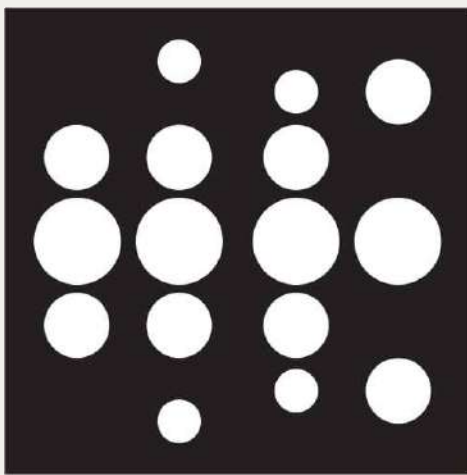

REFLECTIVE SYMMETRY (HORIZONTAL)

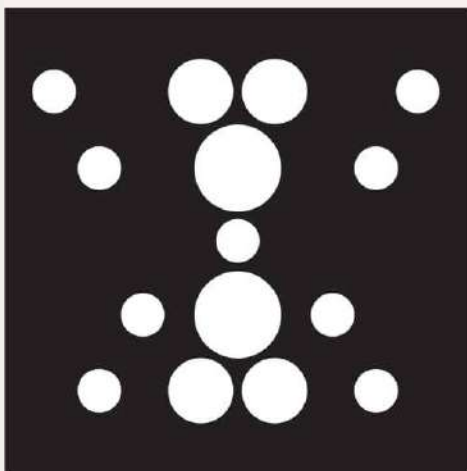
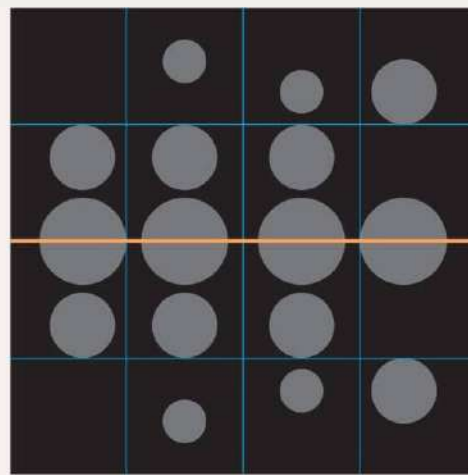

REFLECTIVE SYMMETRY (VERTICAL)

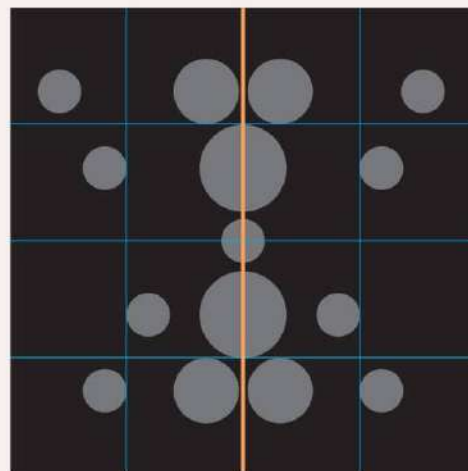

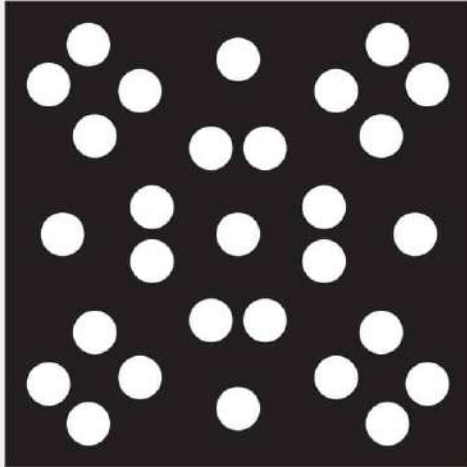

ROTATIVE SYMMETRY

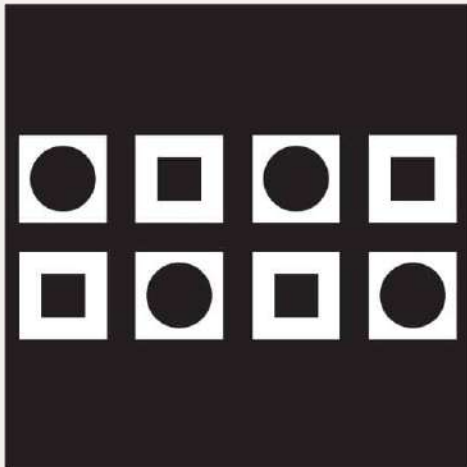
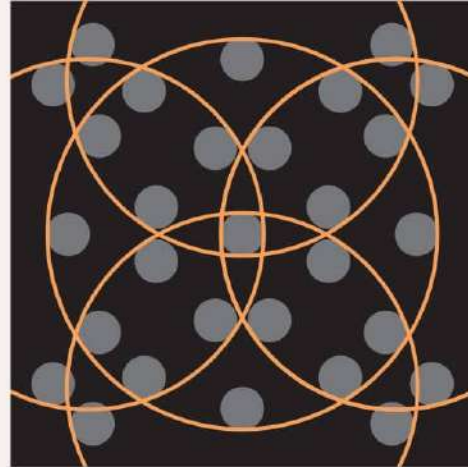

TRANSLATIVE SYMMETRY

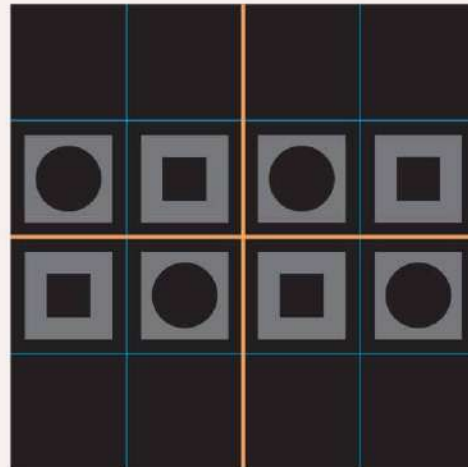

The compositional principle of symmetry has also long been associated with physical beauty, natural or man-made. Symmetry can be found in virtually all forms of the natural world, including the human body, animals, and plants. Classical architecture also possesses combinations of symmetrical types, creating unified, dynamic, and memorable forms. Prime examples found in the man-made environment are Notre-Dame Cathedral (ca. 1163), the Eiffel Tower (1889), and the U.S. Capitol Building (1793).

Types of Symmetry

There are three distinct types of basic symmetry:

Reflective Symmetry

Horizontal and vertical symmetry are identified as “reflective” symmetry. This

type of symmetry is created by mirroring equivalent elements around a central axis or mirror line of a compositional layout. This can be achieved in any orientation as long as its elements are the same on both sides of the mirror line. Natural forms, such as that of a monarch butterfly, exhibit reflective symmetry.

Horizontal symmetry is created with an imaginary horizon or a left-to-right line functioning as the divider of a compositional layout with the top and bottom sections mirroring one another. A landscape reflected in a still pond is an example of horizontal reflective symmetry.

Vertical symmetry is created with an imaginary vertical or a top-to-bottom line functioning as the divider of a compositional layout with the left and right sections mirroring one another. A Rorschach ink blot is an example of vertical symmetry.

Rotative Symmetry

Rotative symmetry is created in a compositional layout by rotating equivalent elements in an outward direction from a common center point while drawing attention inward. This type of symmetry can occur at any angle or frequency as long as its elements share a common center point. Arabesque and mandala patterns are examples of man-made rotative symmetry. Natural forms, such as a sunflower, are also examples of rotative symmetry.

Translative Symmetry

Translative symmetry is created by locating equivalent elements in different areas of a compositional layout. This type of symmetry can occur in any direction and over any distance as long as the basic orientation of its elements is maintained. Continuous patterns found in architectural surfaces such as friezes and brick facades are examples of translative symmetry.

Aside from its aesthetic properties, symmetry has other characteristics that are potentially beneficial to graphic designers. For example, symmetrical forms are seen as figure elements rather than ground elements in a compositional layout. They receive more attention and are more memorable than other compositional organizations. Symmetrical forms are also simpler than asymmetrical forms, which makes them more immediate and recognizable to a reader's eye.

Contemporary Influence:

Jan Tschichold and The Penguin Classics

In 1947, Jan Tschichold (German, 1902–1974) emigrated from Switzerland to Great Britain to accept a position at Penguin Books as its new design director. Founded in 1935, Penguin Books was one of the most commercially successful book publishers in Great Britain.

Prior to Tschichold's arrival, Penguin paperbacks were not produced with any contemporary design standards or production criteria. Their existing standards, however dated and limited, were generic and inappropriate in comparison to the publisher's literary reputation and offerings. Tschichold quickly realized that a new and unique set of compositional rules and standards were needed.

Here Tschichold established a new standard for book design in Great Britain, as well as worldwide, for generations to come. His redesign of Penguin books in the late 1940s not only revolutionized typographic conventions, but also reintroduced compositional standards that had been labeled as out of date. In his view, adherence to the tenets of classical typography— symmetry, legibility, a balance of type styles, wide margins, contrast, simplicity, and integrated rules and ornaments—were all integral to a book's timeless function.

Tschichold had begun to reject the rules of *Die Neue Typographie* (*The New Typography*, 1928) and functional Bauhaus principles while designing books in Switzerland between 1933 and 1946. He realized then that symmetrical and asymmetrical typographic treatments could meet the requirements and goals of successful book design. Years later, in a 1959 lecture presented at the Type Directors Club in New York City, he stated, "Obeying good rules of composition

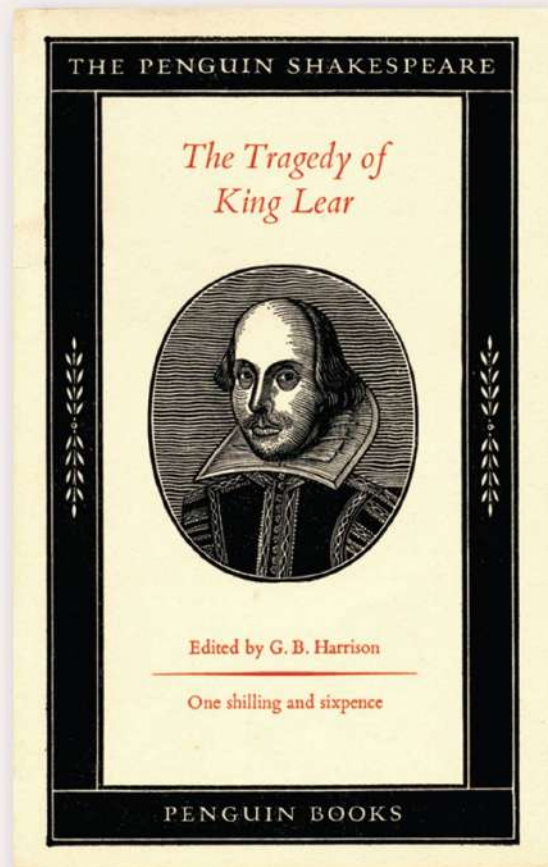

and book design in the manner of traditional typography is not ‘putting the clock back.’”

While at Penguin, he established a new set of general design principles that were based on his broad vision of good design. These guidelines were documented in a four-page essay entitled *Penguin Composition Rules*, which demanded that all Penguin designers follow these standardized rules for all aspects of book design and compositional layout.

Tschichold also designed many book covers himself, including the Penguin edition of Shakespeare’s *The Tragedy of King Lear*, released in 1949. While conventional in design, combining a small engraving by the noted artist and engraver, Reynolds Stone (British, 1909–1979), with typography by Tschichold, it is a clear and well-balanced composition that is immediately legible to a reader. Its solid black border is reinforced by inset hairline rules that provide a strong frame for the symmetrical typography set in Monotype’s Perpetua (Eric Gill, 1929). During his tenure, Tschichold standardized the design for Penguin’s extensive book series, and *The Tragedy of King Lear* is a prime example of the basic compositional principles he devised for Penguin Classics, making them instantly recognizable to the consumer.

By raising the aesthetic level of a mass-market publisher of paperback books, Tschichold brought to life the timeless principle of symmetry that graphic designers still rely upon today. He later wrote, “We do not need pretentious books for the wealthy; we need more really well-made ordinary books.”

Image: ©1970 Penguin Books Ltd.

Asymmetry

Asymmetry is the opposite of symmetry. Asymmetrical balance, also called informal balance or dynamic balance, means without symmetry. This definition by itself has nothing to do with balance. It only means that images within a compositional layout do not mirror one another, appear random and dynamic, lack balance, and appear visually off-kilter. The term, however, is normally used to describe a kind of balance that does not rely upon symmetry.

Asymmetry

Asymmetry in a compositional layout is achieved when visual elements do not mirror one another, appear random and dynamic, lack balance, or appear visually off-kilter. Asymmetrical layouts often have one dominant form or compositional element that is offset by smaller forms or compositional elements. In general, asymmetrical compositions tend to have a greater sense of visual tension than symmetrical compositions. Asymmetrical balance is informal, active, and dynamic and completely dependent upon contrast and counterpoint in a compositional layout.



PLACEMENT

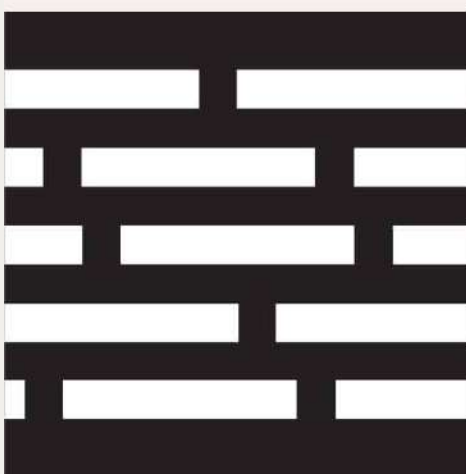
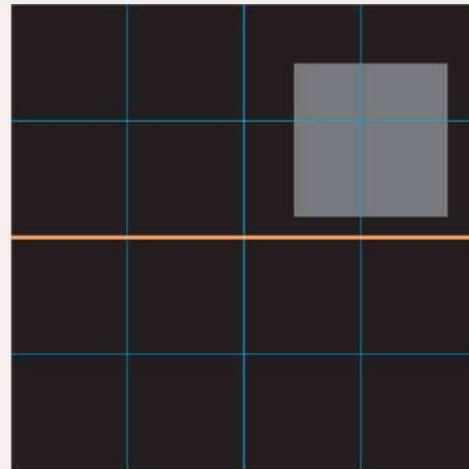

ALIGNMENT

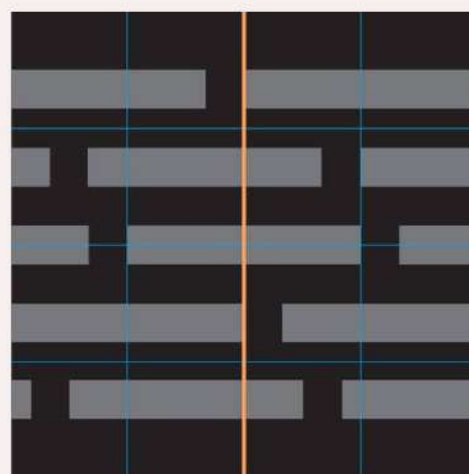

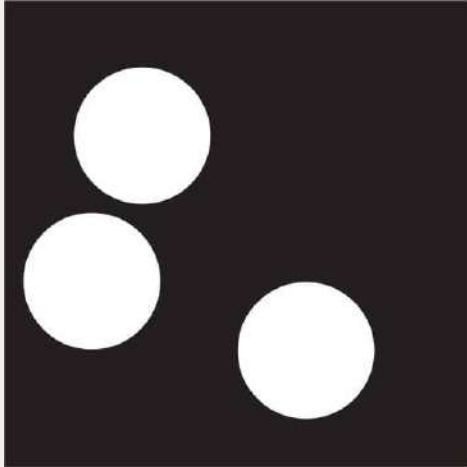

ORGANIZATION

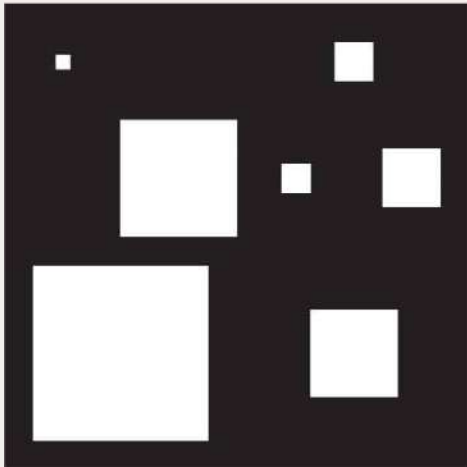
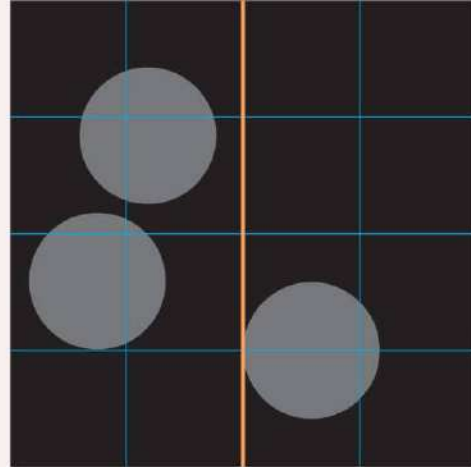

SCALE

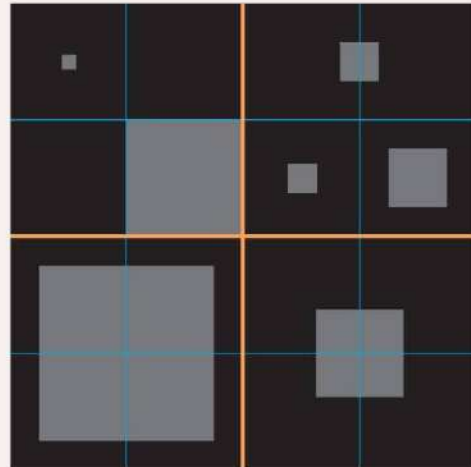

Contemporary Influence:

Jan Tschichold and *The New Typography*

Jan Tschichold (German, 1902–1974) was born in Leipzig, Germany, the eldest son of a sign painter and calligrapher. He studied calligraphy, engraving, typography, and book arts at Leipzig's Academy for Graphic Arts and Book Production. Soon after establishing himself as a graphic designer, he became aware of the need for a new approach to typography.

At the time, typography was based on the principle of centered type or symmetry, using frame, border, and ornament to provide texture, distinction, and individuality to each composition. Tschichold identified this approach as the “box block style” of typography, an approach that was predictable, uninteresting, and outdated.

In August 1923, he attended the first Bauhaus exhibition in Weimar and quickly started to assimilate this new design philosophy. Influenced and informed by the work of modern, avant-garde artists and designers such as Herbert Bayer (Austrian, 1900–1985), Paul Klee (Swiss, 1879–1940), El Lissitzky (Russian, 1890–1941), and Piet Zwart (Dutch, 1885–1977), Tschichold wanted to liberate visual communications from the restrictive rules of the time and provide designers with greater freedom and flexibility.

He believed that typographic information had to be purely functional and composed in a clear and precise manner or else it would be ignored. Starting in 1925, he began producing a series of articles and publications that proposed a revolutionary approach to a “new” typography—an approach strongly influenced by both the Bauhaus and the Russian Constructivists.

The major tenets of *The New Typography* were asymmetric compositions of elements based on their relative importance, the preference for sans serif type, and the creative use of white space. These tenets were ultimately summarized in Tschichold's treatise entitled *Die Neue Typographie (The New Typography, 1928)* and in *Typographische Gestaltung (Asymmetric Typography, 1935)*. These tenets are further illustrated by his poster, *Konstruktivisten* (1937; see right).

In 1933, Tschichold was arrested and accused by the Nazis of being a “cultural bolshevik” and creating “un-German” typography. Soon after his release, he and his family emigrated to Basel, Switzerland. In the later part of his life, Tschichold ultimately embraced both symmetry and asymmetry, as well as the use of serif and sans serif typography in his work.

Image: ©ZHdK, Museum für Gestaltung Zürich, Poster Collection.

With asymmetry, there is often one dominant form or compositional element that is offset by many smaller forms or compositional elements. In general, asymmetrical compositions tend to have a greater sense of visual tension than symmetrical compositions.

Asymmetry in Nature

Asymmetry in nature is uncommon and is a trait identified as “handedness.” This trait is defined as a property of an object (such as a living organism) not being identical with its mirror image. This is fully evident in a person’s tendency to use one hand rather than the other.

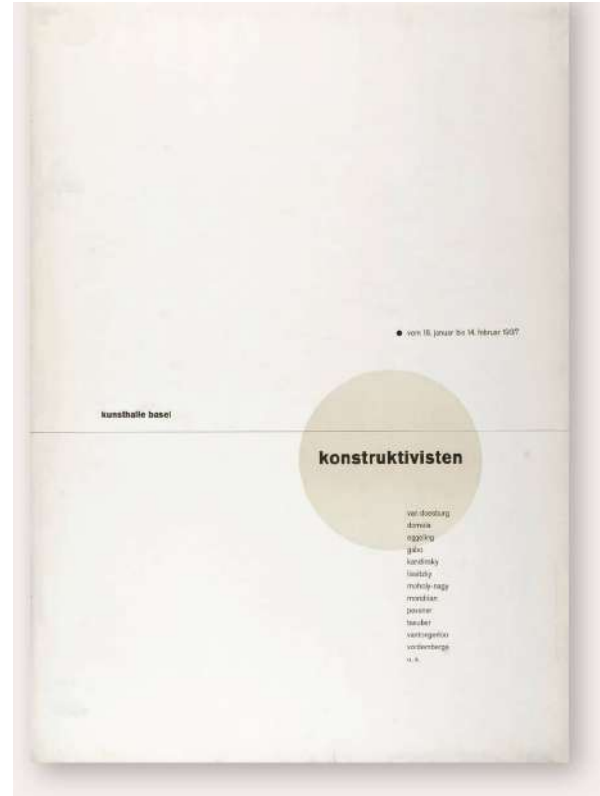

Other examples of handedness and left– right asymmetries in nature include the left dolphin lung being smaller than the right to make room for their heart positioned to the left side; a fiddler crab’s different-sized claws; the narwhal’s left incisor tusk which can grow up to 10 feet in length and form a left-handed helix; the eyes of a flatfish which are located on one side of their head causing them to swim with one side upward; and several species of owls whose size and positioning of their ears help them locate their prey.

Compositional Characteristics

Asymmetry is achieved when one side of a compositional layout does not reflect the other side. Asymmetrical balance is a type of visual balance in which compositional elements are organized by a graphic designer so that one side differs from the other without impacting the composition’s overall harmony. Consequently, when an asymmetrical composition is disturbingly off balance, the result is jarring and disorienting.

As a compositional principle of graphic design, asymmetrical balance is more complex and more difficult to achieve than symmetrical balance. It involves the organization of compositional elements in a way that will allow elements of varying visual weight to balance one another around an axis or pivot point. This can best be visualized by envisioning a literal balance scale that represents their visual weights in a two-dimensional compositional layout. For example, it is

possible to balance a heavy weight with a group of lighter weights on equal sides of a pivot point. In a compositional layout, this might be a cluster of small elements balanced by a larger one. It is also possible to imagine compositional elements of equal weight but of different mass (such as a large mass of feathers versus a small mass of stones), on equal sides of a pivot point. Unequal visual weights can also be balanced by shifting the pivot point on this imaginary scale.

Asymmetrical balance is informal and generally more active and dynamic than symmetrical balance. While symmetrical balance is achieved by reliance upon repetition, asymmetrical balance is completely dependent upon contrast and counterpoint in a compositional layout. It is the result of combining contrasting design elements, such as point, line, shape, form, and color, evenly along an axis of a composition.

Asymmetry is also a compositional state whereby elements are organized in a nonsystematic and organic manner to achieve visual balance. This type of visual balance relies upon the critical interaction and integrity of compositional elements and negative space, as well as their location and proximity to one another, to create tension, balance, and ultimately meaning in graphic design. These types of balanced compositional layouts are inherently active and kinetic, and communicate the same to a reader.

Contemporary Influence:

Piet Zwart and Asymmetrical Tension

Piet Zwart (Dutch, 1885–1977), a craftsman, draftsman, and architect, was born in Zaandijk, an industrial area north of Amsterdam. From 1902 to 1907, he attended Amsterdam's School of Arts and Crafts where he became interested in architecture. His early work involved the design of textiles, furniture, and interiors, in a style that showed his affinity for the de Stijl movement.

Zwart was influenced by many of the modern, avant-garde movements of the early twentieth century, as well as Tschichold's (German, 1902–1974) *The New Typography* (1928). He was one of the first modernist designers in Holland to apply the principles of de Stijl and Constructivism to commercial advertising during the 1920s.

From 1921 to 1927, Zwart worked for H. P. Berlage (Dutch, 1856–1934), the most influential Dutch architect of the era. While working in Berlage's office, he received his first typographic commission and designed the first of many advertisements for Laga Company, a Dutch flooring manufacturer. These dynamic and arresting advertisements are early examples of Zwart's interest in typography, pure compositional form, and asymmetrical tension. Here, he mostly used found type and letterforms from various printers' cases. While photographs and photomontage were used sparingly, when he did rely on these forms, they were never used as embellishment or decoration. Every visual element, whether typographic or photographic, was used to collectively create a more meaningful and powerful message.

With this early work, he rejected conventional symmetry and traditional typographic rules. Zwart considered the design of a visual composition as a "field of tension" brought to life with a combination of asymmetrical balance, contrasts



the size of elements, and a dynamic interaction between positive and negative space.

Zwart created a synthesis of two distinct and contradictory points of view—the Constructivist Movement’s visual play-fulness and de Stijl’s formal functionality. He was able to create a unified language that has prevailed for the last eighty years, and to this day is still a strong influence for contemporary designers.

Image: ©Gemeentemuseum Den Haag.

Asymmetrical compositional layouts require a more disciplined and analytical eye, due to their unique and ever-changing spatial requirements. Here, you are required to constantly and consistently evaluate and assess potential compositional solutions, taking into account that spatial relationships vary, from element to element and size to size, whether positive or negative, figure or ground.

In graphic design, your reliance upon the principle of asymmetry in creating asymmetrical compositional layouts increases the viewer’s ability to organize, differentiate, and interact with visual and narrative content.

Tension

The design principle of tension in graphic design is a critical component of effective graphic design. Tension is primarily a visual, as well as psychological, attention-getting device. It is also a tenuous balance that is maintained in a compositional layout between opposing formal elements, which can prompt anxiety, stress, angst or excitement, exuberance, and joy in a reader.

Tension and balance are interrelated elements in graphic design. Like balance, tension is an obvious and constant presence in our everyday lives. Unfortunately, we cannot experience one without the other. When something is out of balance in our life, we immediately feel tense and anxious. For example, when we observe a daring feat, such as a high-wire act in the circus, it makes us feel uneasy and tense, since there is always the possibility of that performer falling. The same experiences and emotions can be conveyed and ultimately felt in any compositional layout.

Visual Characteristics and Effects

Tension is a critical compositional element that is completely dependent on opposing visual forces. For example, in the related fields of applied and performing arts, such as architecture, music, and dance, the same holds true. In architecture, monumental structure is juxtaposed with curvilinear, natural form

architecture, monumental structure is juxtaposed with curvilinear, natural form in the Eiffel Tower (1889) and Guggenheim Museum (1959). In music, loud sounds compete with soft tones in the compositions of Peter Ilyich Tchaikovsky (Russian, 1840–1893) and Philip Glass (American, b. 1937). In dance, movement that appears harsh and irregular is set against fluid, gentle gestures in the choreography of Martha Graham (American, 1894–1991) and Merce Cunningham (American, 1919–2009).

Tension can be realized through a variety of contrasts and imbalances—between medium and message, form and content, pattern and texture, and scale and proportion. It is the result of opposing forces and unresolved relationships, not only in visual form, but also in narrative content.

It can also be achieved by relying on the compositional element of space. As a general rule, varied proximity of elements can result in visual tension that brings apparent and dynamic interest to a compositional layout. Equal and regular spacing between graphic elements of similar size can result in a static, uniform composition.

Tension

Tension is a compositional principle and visual, attention-getting device completely dependent on opposing visual forces. It can be realized in any compositional layout through a variety of contrasts and imbalances— between medium and message, form and content, and pattern and texture, as well as scale, spacing, placement, and orientation.

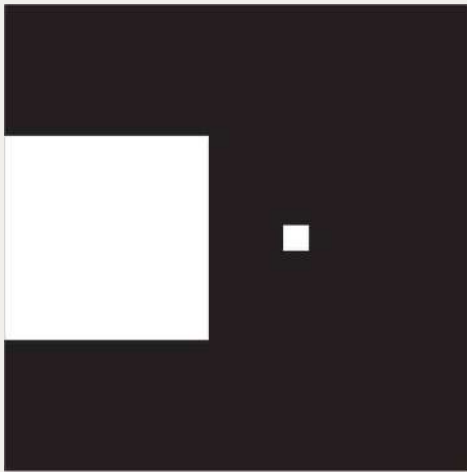

SCALE

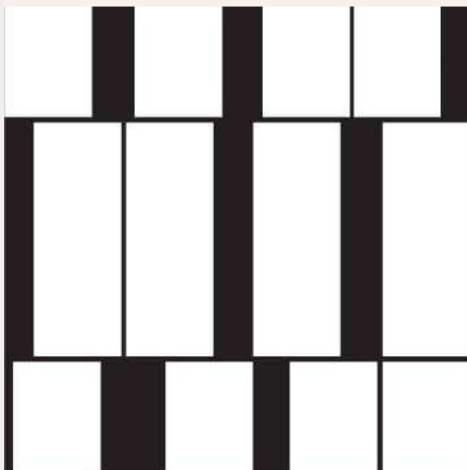
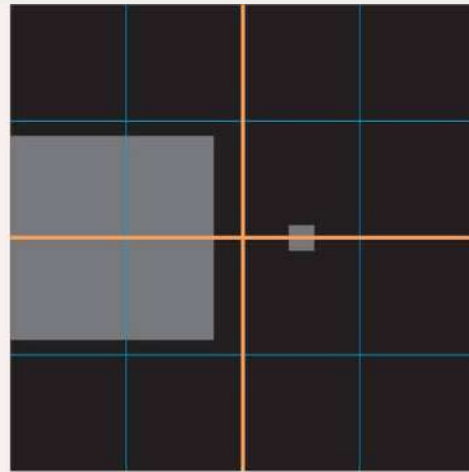

SPACING

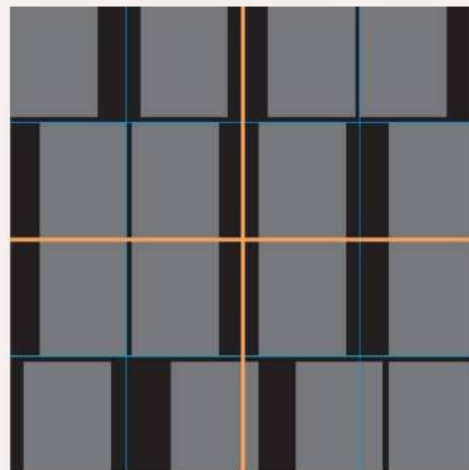

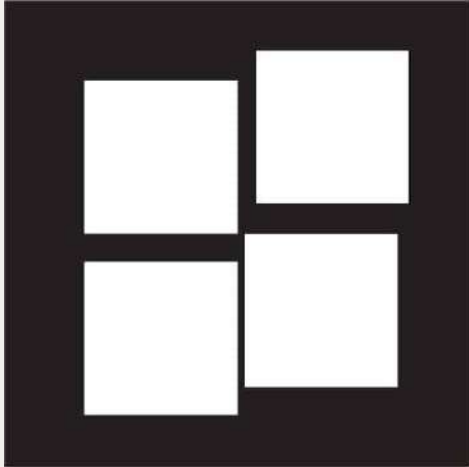

PLACEMENT

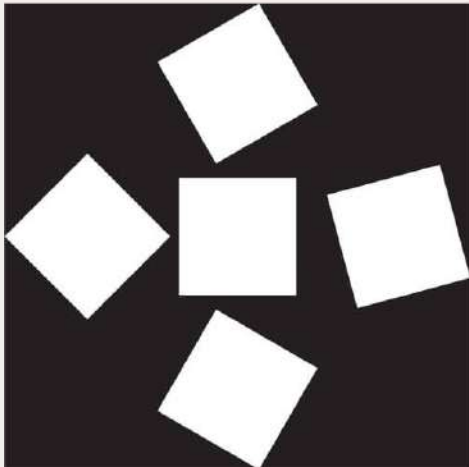
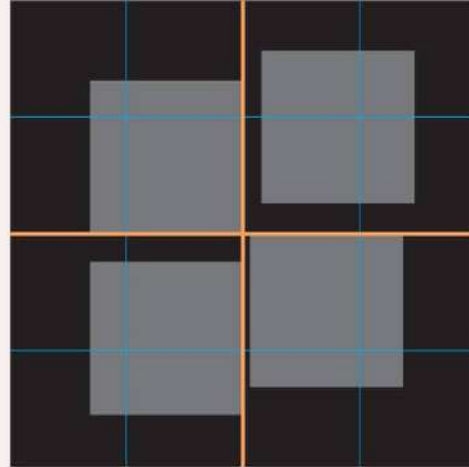

ORIENTATION

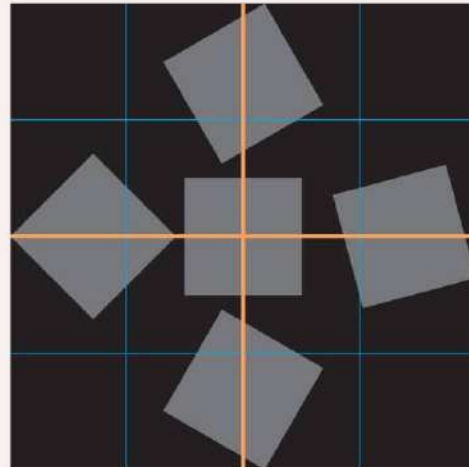

Tension

Tension can also be achieved in any compositional layout by relying on the visual characteristics of alignment, form, proportion, texture, and space. For example, varied proximity of elements can result in visual tension that brings apparent and dynamic interest to a compositional layout. A space located between two or more compositional elements can affect not only their spatial relationship but also have an impact on how that spatial relationship is perceived by a reader.

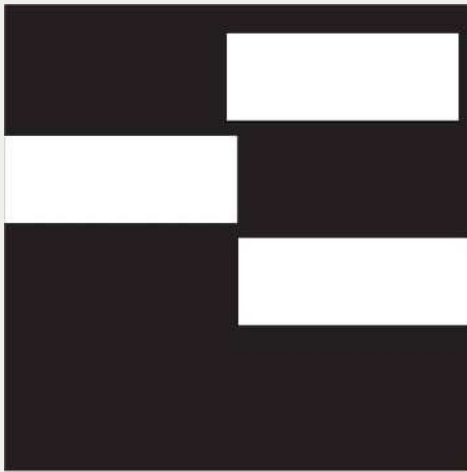

ALIGNMENT

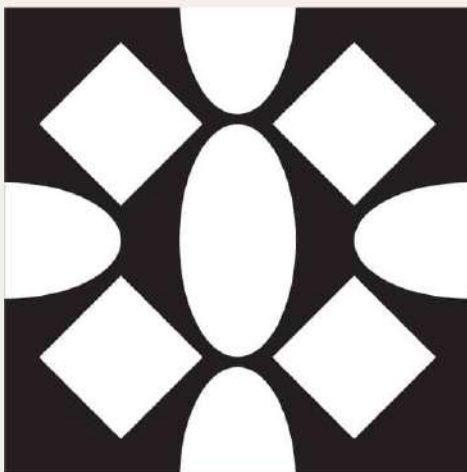
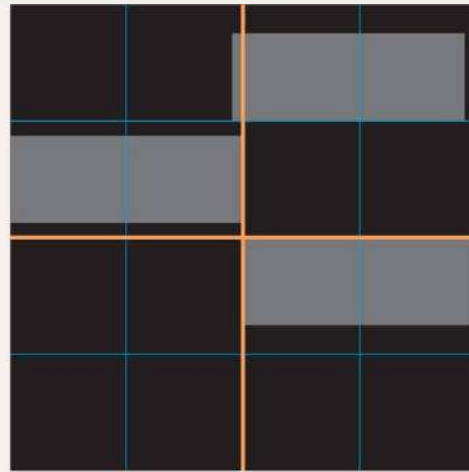

FORM

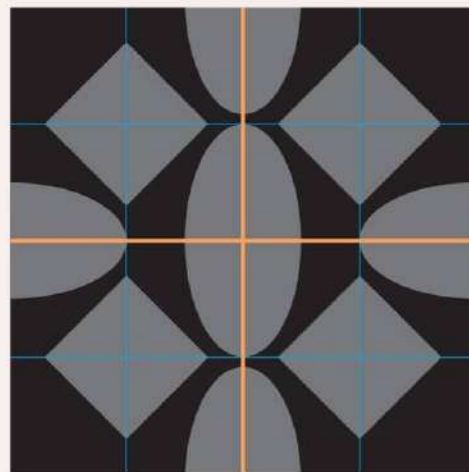

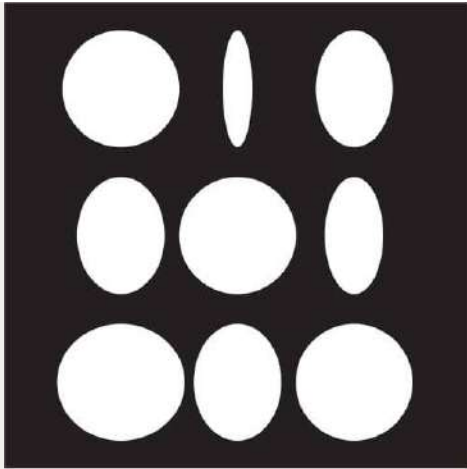

PROPORTION

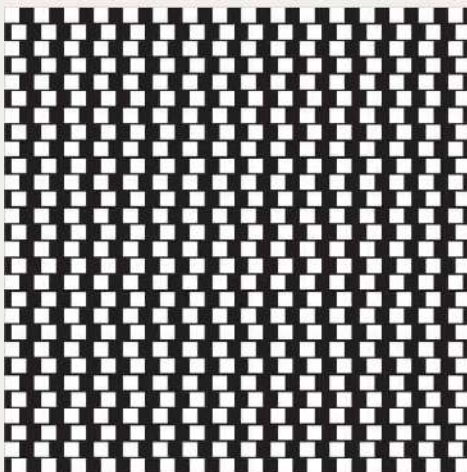
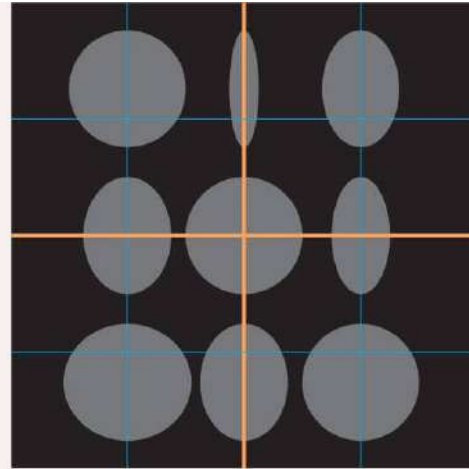

TEXTURE

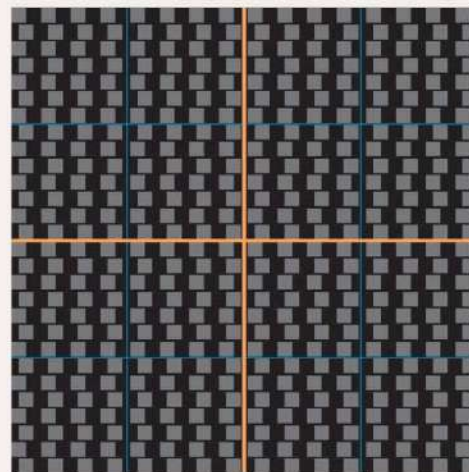

For example, a space located between two or more compositional elements can affect not only their spatial relationship but can also have an impact on how that relationship is perceived by a reader. As these two or more elements move together, a visual tension can result. When they touch, a new or hybrid shape is created. And at some point, as they move apart, they become disassociated from one another. A graphic designer can think of tension as a conversation in which compositional elements communicate with one another. This conversation can be quiet and understated, or it can be loud and chaotic. The resulting dialogue can be affected profoundly by the position and number of elements in a compositional layout. Proximity groupings can create patterns, a sense of rhythm, or other visual relationships that potentially can elicit a response from a reader. However, you need to keep in mind that this conversation should always be in support of the visual and narrative content of the message.

The effect of tension can also be created by an imbalance of elements in a compositional layout. With asymmetrical compositions, visual tension is produced in response to gravity and its effect on the individual elements of a composition. It can create varied degrees of visual excitement, depending on the degree of asymmetry used in a compositional layout.

Our lives are filled with opposites—happy, sad; angry, calm; crying, laughing. Effective graphic design echoes these opposites in our lives, making us connect and engage with them in a much more immediate and meaningful way. This language of opposites is a language of tension, and it helps us understand so many things and experiences. Visual tension speaks to the good and the bad, the easy and the difficult—in life, as well as in graphic design. Good and effective graphic design is often filled with tension.

Contrast

Contrast is a visual principle that fundamentally provides the eye with a noticeable and obvious difference between two elements or objects—large and small, red and green, light and dark, or hot and cold. In graphic design, contrast is the perceptible difference in visual characteristics that makes an object (or its representation in an image) distinct from other objects in a compositional layout, as well as its surrounding background. Contrast used in a compositional layout is the opposite of visual harmony.

It can be achieved by exaggerating the visual differences in size, shape, color, and texture between compositional elements, thereby making a message more immediate and understandable to a reader. Contrast can draw attention, create a mood or emotion, and create hierarchy and emphasis in complex information in any compositional layout.

Comparative Relationships

Traditionally, contrast is the comparative relationship between light and dark. There are many other types of contrast in graphic design, which refer to comparative relationships or juxtapositions between two or more compositional elements. These juxtapositions can be of positive and negative, geometric and organic, organized and chaotic, smooth and rough, static and kinetic, and large and small.

Contemporary Influence:

Emil Ruder and the Importance of Contrast

Emil Ruder (Swiss, 1914–1970) was a typographer, graphic designer, and educator who was instrumental in starting the Allgemeine Gewerbeschule (Basel School of Design), as well as the development of the International Typographic Style, also known as the Swiss School. As a young man, he studied in Paris and trained as a typesetter in Zürich. In 1929, at the age of 15, he began a four-year compositor's apprenticeship and attended the Zürich School of Arts and Crafts. In 1948, Ruder met the artist-printer Armin Hofmann (Swiss, b. 1920) and they began a long period of collaboration and teaching that achieved an international reputation by the mid-1950s.

Ruder was also a writer and published a basic grammar of typography entitled *Emil Ruder: Typography*, in German, English, and French, in 1967. This groundbreaking book helped spread the International Typographic Style and became a basic text for graphic design and typography through-out Europe and the United States. The International Typographic Style was defined by the use of sans serif typefaces and employed a rigorous page grid for structure that produced asymmetrical layouts. Its philosophy and tenets evolved directly from the de Stijl Movement, the Bauhaus, and Jan Tschichold's *The New Typography* (1928).

In Ruder's work, as well as in his teachings, he called for all graphic designers to find an appropriate balance between form and function. He believed that typography loses its function and communicative value when it loses its narrative meaning. He further believed that typography's primary role in any visual composition is legibility and readability. A careful and critical analysis of visual contrasts, or the contrast of macro and micro, was essential to understanding both of these parameters—the negative or "white" space of the page, as well as the negative or "white" space of letter and word forms, such as counters, letter spacing, and word spacing.

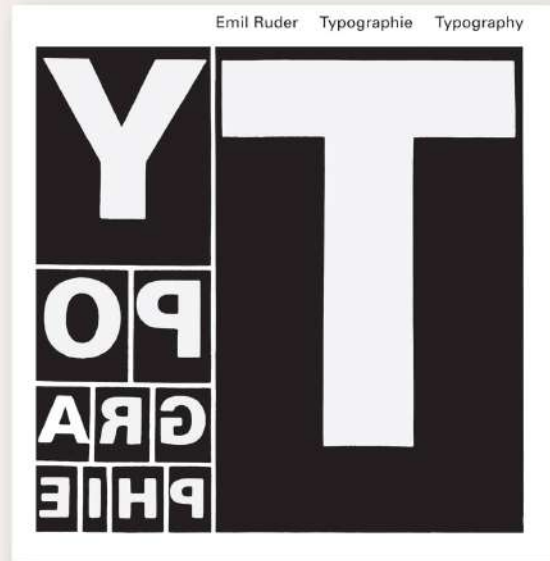

He also promoted an overall, systematic approach to the design of page layout and the use of complex, structured grids to bring all compositional page elements into a unified, cohesive whole, while still allowing for contrasting variations in design and content.

Image: ©Niggli Publishers.

Contrasting relationships can be further articulated using a combination of elements to achieve variety and unity in a compositional layout. Here, the ultimate challenge is to create a composition composed of disparate elements, making them work together as one orchestrated visual whole. Contrasting size, order, weight, direction, configuration, value, color, texture, and form can all add to creating effective and meaningful visual interest by allowing one element to contrast and complement the other. For example, a serpentine curve appears more curvilinear when located in close proximity to an element that is extremely orthogonal and straight. A color such as red, will always appear redder when it is adjacent or surrounded by its complementary color, green.

Visual Characteristics and Functions

Contrast is another way to create emphasis by establishing juxtaposition with compositional elements to stress their visual differences. For example, bright colors juxtaposed with dark colors, angular shapes with curvilinear shapes, and minuscule elements with monumental elements can create visual excitement and emphasis, as well as drawing direct attention to focal points in a compositional layout and organizing hierarchical orders in a visual message.

Contrast imparts emphasis, importance, weight, or dominance to an element of a compositional layout. A compositional layout lacking contrast may result in visual monotony, neutrality, and even confusion.

Types of Contrast

Creating contrast means effectively using opposing elements, such as tone, color, and shape, to produce an intensified visual effect in a compositional layout.

For example, chiaroscuro (Italian for 'light-dark') in fine art and photography is characterized by strong tonal contrasts between light and dark, usually bold contrasts affecting a composition. It is also a technical term used by artists and art historians for using contrast of light and dark or tone to achieve a sense of volume in modeling three-dimensional objects such as the human body.

Since we live in a world of color, the use of it as a contrasting force can

immediately be understood by the viewer when conveying or emphasizing differences among visual elements in a compositional layout. Distinct contrasting shapes can also produce striking reactions from a reader. For example, a conventional shape appears more conventional and normal when an irregular, non-conventional shape is present in the same composition.

Contrast can exist on many obvious and subtle levels in a compositional layout. The human eye can simultaneously detect contrasts in scale, value, shape, direction, and surface. Contrast can also clarify and strengthen a compositional layout by lending stability and clarity to the cohesiveness of the composition, draw the eye's attention to a specific area, and affect the figure-ground relationship by maximizing or minimizing its visual immediacy.

Contrast

Contrast provides noticeable and obvious differences, such as size, shape, color, value, placement, texture, and weight, between two or more visual elements in a compositional layout, thereby making a message more immediate and understandable to a reader. It can draw and direct attention, create a mood or emotion, and establish hierarchy and emphasis in complex information. This compositional principle is based on comparative relationships between two or more visual elements such as light and dark, positive and negative, geometric and organic, organized and chaotic, smooth and rough, static and kinetic, and large and small.

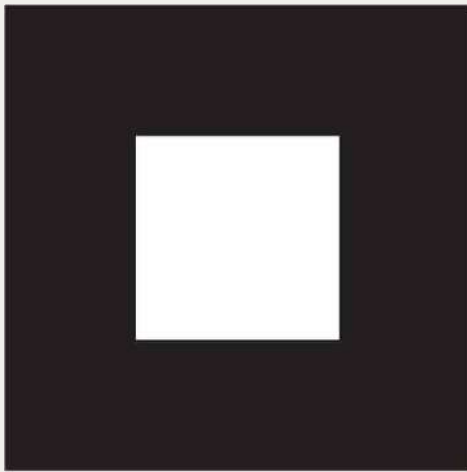

COLOR/VALUE (HIGH CONTRAST)

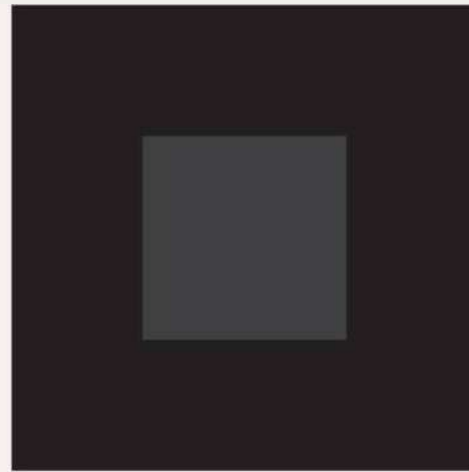

COLOR/VALUE (LOW CONTRAST)

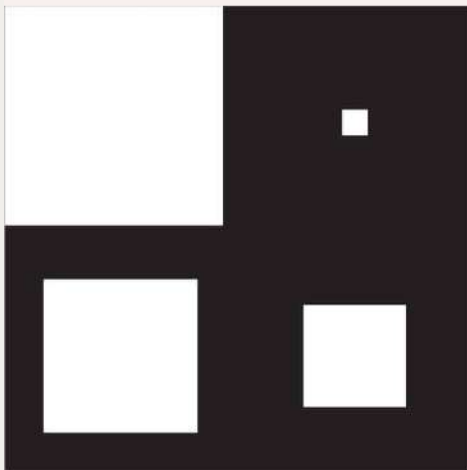

SCALE (CONTRAST)



SCALE (NO CONTRAST)

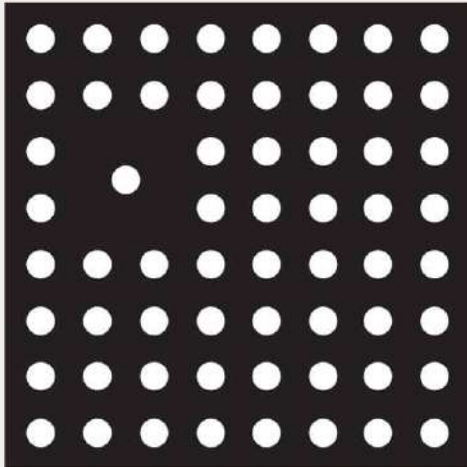

ISOLATION

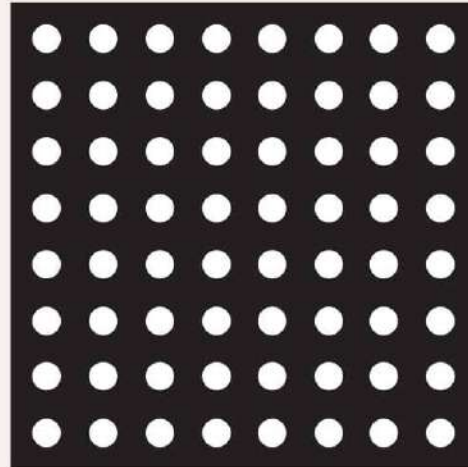

NO ISOLATION

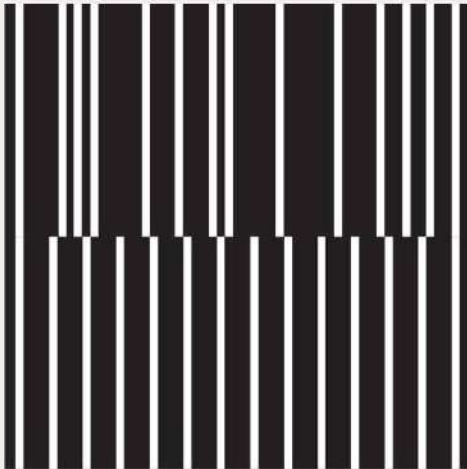

TEXTURE (CONTRAST)

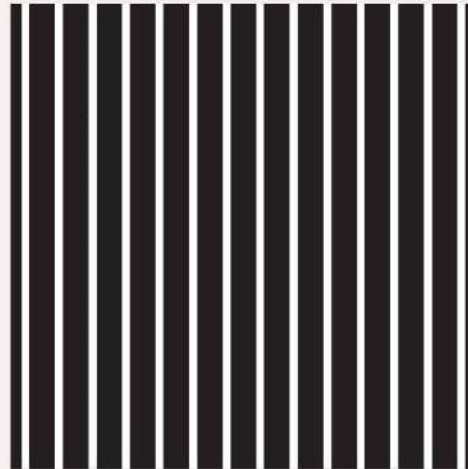

TEXTURE (NO CONTRAST)

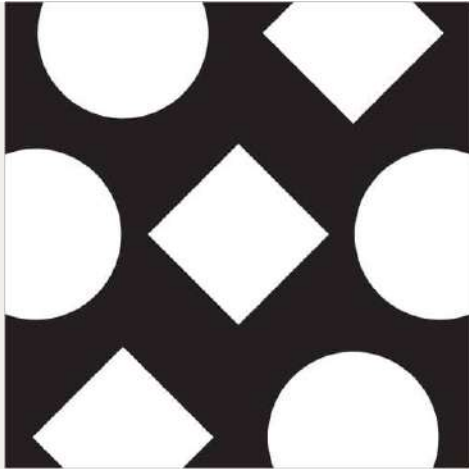

SHAPE (CONTRAST)

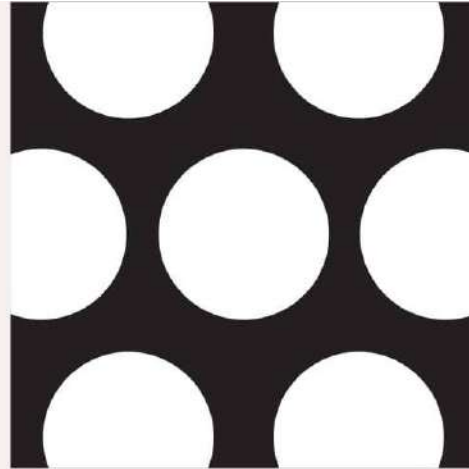

SHAPE (NO CONTRAST)

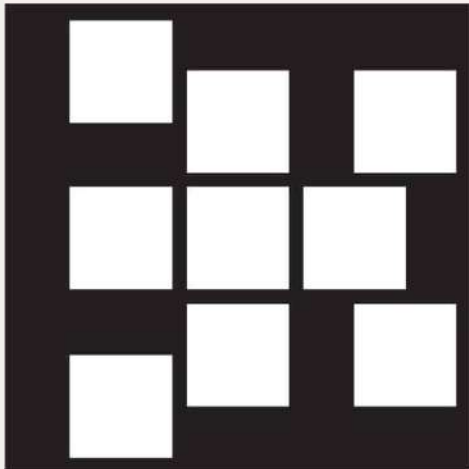

PLACEMENT (CONTRAST)

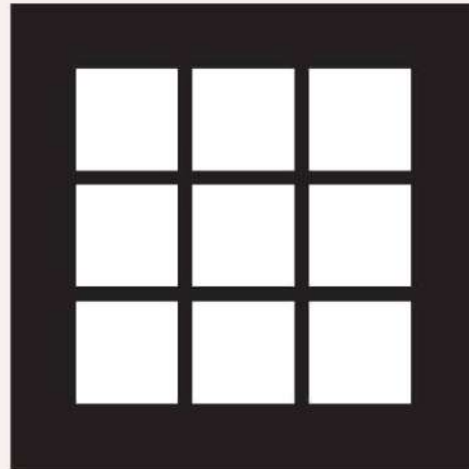

PLACEMENT (NO CONTRAST)

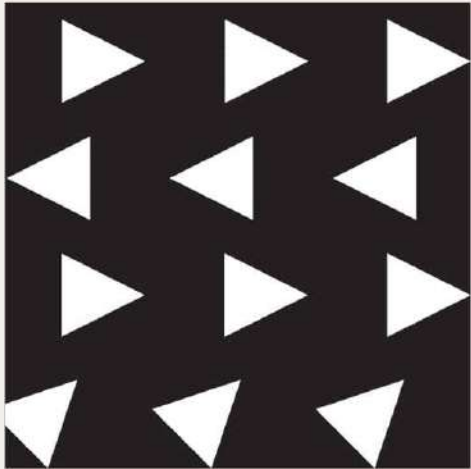

MOVEMENT (CONTRAST)

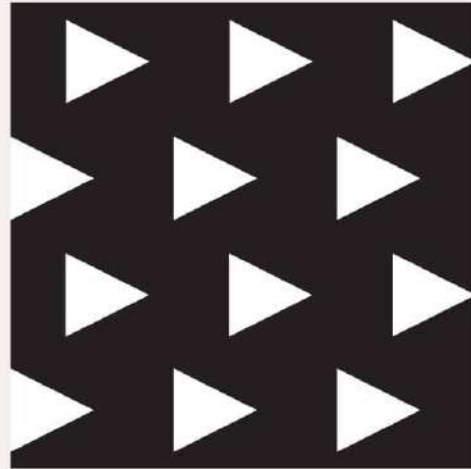

MOVEMENT (NO CONTRAST)

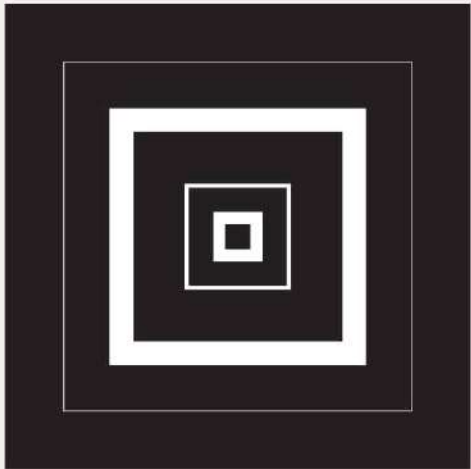

WEIGHT (CONTRAST)

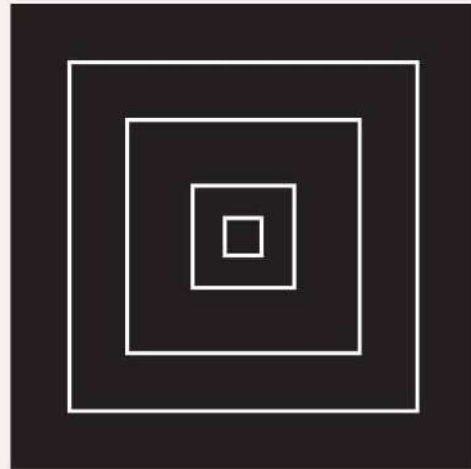

WEIGHT (NO CONTRAST)

Figure-ground

Figure-ground is a compositional principle based on the visual relationship between the foreground and background of any compositional layout. Visual elements in a layout are perceived as either figure (object or focus) or ground (the remaining background or the rest of the perceptual compositional field). Figure is a positive compositional visual element, while the space or ground around it is considered opposite and a negative compositional element. Both elements are mutually dependent on one another, therefore it is impossible to change one without affecting the other.

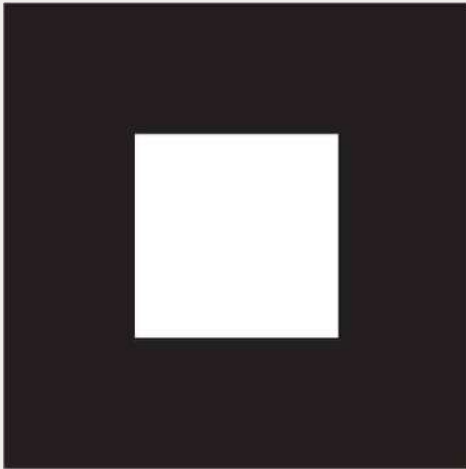

SIMPLE

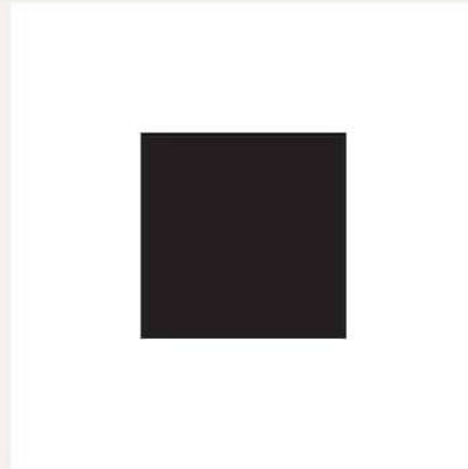

REVERSAL



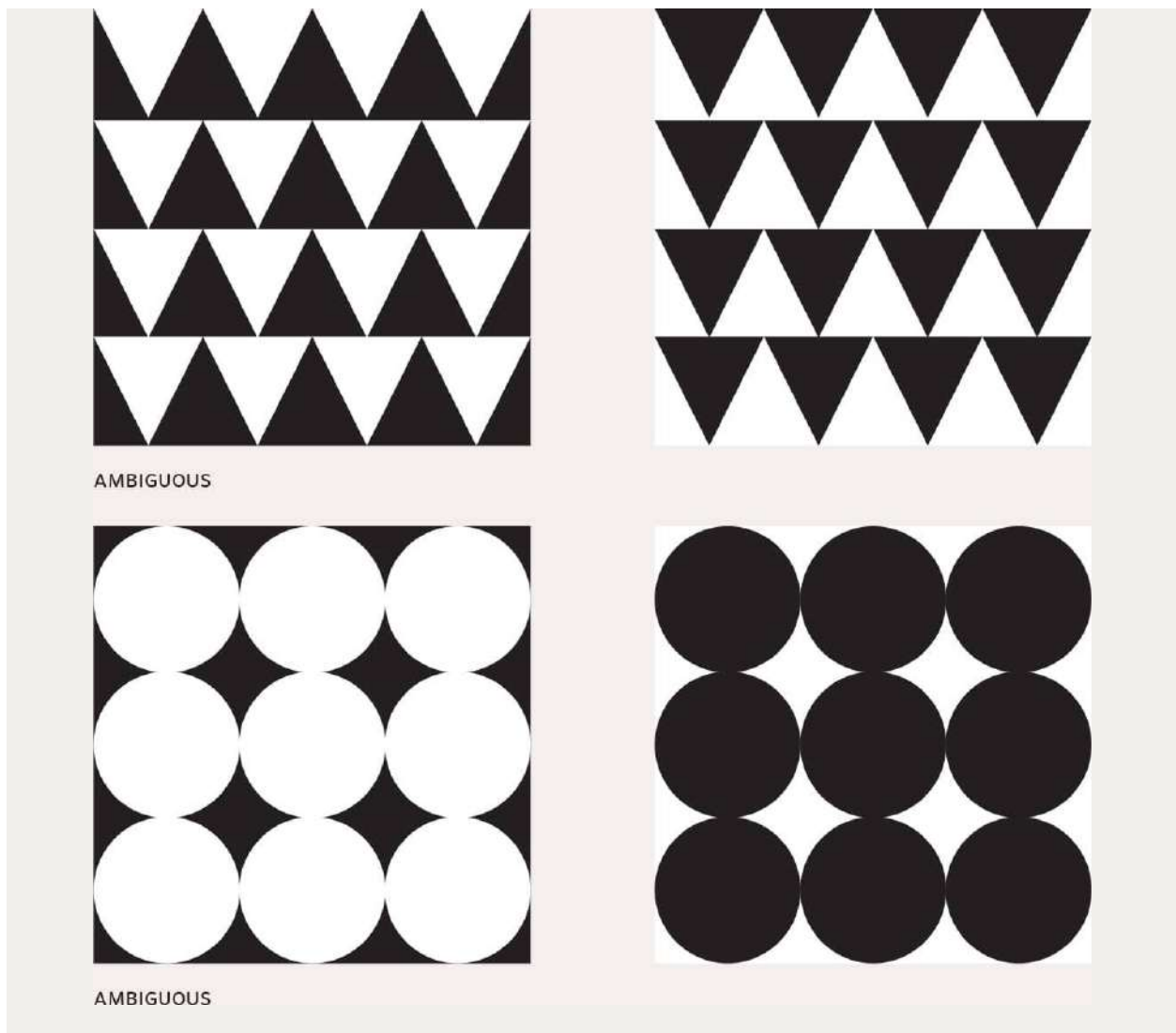

Figure-ground

Figure-ground is primarily the visual relationship that occurs between the foreground and background of a compositional layout. This relationship is one of the primary principles of visual perception and graphic design. Related design principles and elements of contrast and shape have a critical and direct effect on how a figure and its ground interact with one another.

Figure-ground also refers to the optical phenomenon that occurs when specific design elements in any compositional layout appear to move forward or recede. For example, this page you are currently reading contains narrative text and images that constitute “figure,” and this book’s white paper constitutes “ground.” How and to what degree these two elements interact, either creating tension or harmony, is fully determined by a graphic designer, and ultimately will contribute to the success or failure of this chapter, as well as your

will contribute to the success or failure of this chapter, as well as your interaction and understanding of this information.

Definition of Elements

Design elements in any compositional layout are perceived as either figure (objects or focus) or ground (the remaining background or the rest of the perceptual compositional field). It is also critical to remember that ground, or the space surrounding a figure, is also a shape. Shapes can exist independently, as well as overlap each other, depending on the specific figure-ground relationship of a composition.

Figure is considered a positive compositional visual element, while the space, or ground, around it is considered opposite and a negative compositional design element. Both are dependent upon one another. It is impossible to change one without affecting the other. Creating dynamic relationships between positive and negative is the cornerstone of well-resolved compositional layouts.

Figure

Figure is a design element that we pay attention to and is identified as a positive shape in a compositional layout. It is defined as the outline, form, or silhouette of an object and refers to an active, positive form revealed against a passive, negative ground. In a simple compositional layout, there may be only one figure that a reader needs to pay attention to. In a more complex compositional layout, there may be multiple figures. Familiar, figurative, and representational objects are easy to see and assimilate as figures.

Ground

Ground is defined as the surrounding space or background of an object or compositional element. It is also defined as the negative space in a compositional layout, as well as everything else in a layout that is not a figure. As attention shifts from figure to figure, the ground also shifts, so that an object can go from figure to ground and back.

Types of Figure-ground

There are three basic types of figure-ground compositions and relationships:

Simple

A simple figure-ground relationship is created when a coherent, independent object is juxtaposed in a compositional space that functions as its surrounding ground. The ground is compressed or shallow, or it can convey an illusion of

depth. In a simple figure-ground, the figure is positive and active, whereas its ground is always negative and passive. In this compositional relationship, the figure is clearly visible and separate from its background.

Contemporary Influence:

Max Bill and the Swiss Modernist Ideal

Born in Winterthur, Max Bill (Swiss, 1908–1994) was an architect, painter, typographer, industrial designer, engineer, sculptor, educator, and graphic designer.

Bill initially studied at the Kunstgewerbeschule and apprenticed as a silversmith, before beginning his studies in 1927 at the Bauhaus in Dessau, Germany with teachers such as Wassily Kandinsky (Russian, 1866–1944), Paul Klee (Swiss, 1879–1940), and Oskar Schlemmer (German, 1888–1943).

He settled permanently in Zürich in 1929, and in 1937 became involved with a group of Swiss artists and designers named the Allianz. The Allianz group advocated the concrete theories of art and design and included Max Huber (Swiss, 1919–1992), Leo Leuppi (Swiss, 1893–1973), and Richard Paul Lohse (Swiss, 1902–1988).

In 1950, Max Bill and Otl Aicher (German, 1922–1991) founded the Ulm School of Design (Hochschule für Gestaltung-HfG Ulm) in Ulm, Germany, a design school initially created in the tradition of the Bauhaus and which later developed a new design education approach integrating art and science. Bill served as the school's director from 1951 to 1956. HfG Ulm is notable for its inclusion of semiotics, the general philosophical theory of signs and symbols, as a field of study. Faculty and students included Tomás Maldonado (Argentine, b. 1922), Josef Albers (German, 1888–1976), Johannes Itten (Swiss, 1888–1967), and Peter Seitz (German, b. 1931). From 1967 to 1971, he was a professor at the Staatliche Hochschule für Bildende Künste in Hamburg and Chair of Environmental Design.

Bill was the single most decisive influence on Swiss graphic design or the International Typographic Style beginning in the 1950s, thanks to his theoretical writing and progressive work. He said, "It is possible to develop an art largely on the basis of mathematical thinking." As a graphic designer, he fully and



enthusiastically embraced the tenets and philosophical views of this modernist movement. The majority of his graphic work is solely based on cohesive visual principles of organization and comprised of purist forms—modular grids, sans serif typography, asymmetric compositions, linear spatial divisions, mathematical progressions, and dynamic figure-ground relationships.

His powerful use of figure-ground relationships is never more evident than in his exhibition poster, designed in 1931, for the Kunstgewerbemuseum in Zürich. The poster's figure-ground is its primary compositional element; its bright white figure is asymmetrically located and set against a muted background tone. The pure geometry of the figure's inner circle is a powerful focal point that is further offset by the pure linear square containing typographic information on the exhibition.

Image: ©ZHdK, Museum für Gestaltung Zürich, Poster Collection.

Reversal

A figure-ground reversal is created when a figure functions as a ground and ground as a figure. This graphic inversion is caused by shapes that form in the spaces located between the figure, thereby creating the reversal. This type of figure-ground composition is a dynamic means to activate neutral white space in a compositional layout. In a simple figure-ground composition, the borders are perceived as limitless, whereas a figure-ground reversal bounds and limits an image.

Ambiguous

An ambiguous figure-ground composition is created when the relationship between a composition's figure (or object) and ground (or space) is undetectable and disorienting, yet fully comprehensible. With this type of figure-ground, a pair of objects share the same edge or profile. A classic example of an ambiguous figure-ground is Rubin's vase, developed by psychologist Edgar Rubin (Danish, 1886–1951). In this image, the black positive space forms two profiles of a human face that appear to be ready to kiss, and the inverse negative space forms a vase. Visually, a reader's concentration on either the black or white makes the illusion alternate between the faces and the vase.

Visual Characteristics

The compositional principle of figure-ground is one of the most basic in graphic design, because it refers to our ability to visually separate elements based on contrast—dark and light, black and white, and positive and negative. In the

simplest terms, the figure is what we notice and the ground is everything else we tend not to notice.

An effective and perceptible figure-ground relationship occurs when the eye can identify a figure as an object distinct and separate from its ground or compositional background. This perception is solely dependent on the design principle of contrast.

When a composition's figure-ground relationship is clear and stable, it is because its figure receives more attention and immediacy than its ground. When an unstable figure-ground relationship occurs, the relationship is ambiguous, and therefore its compositional elements are interpreted in different ways.

Balanced and effective figure-ground relationships can animate any compositional layout, adding visual impact and power to its message. However, when a figure dominates its ground, the effect can be clear but potentially boring. Locating a clearly defined object in the center of a compositional layout leaves no doubt about the subject, but its presentation may lack visual nuance and power.

Ultimately, figure-ground is one of the most important design principles to consider when creating any compositional layout. In doing so, you can further guarantee that your work will be effective, communicative, memorable, and highly meaningful to a reader. ¶

Test your Knowledge

1. Name three (3) distinct types of visual balance.
2. What are the primary visual characteristics of formal balance, or symmetry?
3. What are the primary visual characteristics of dynamic balance, or asymmetry?
4. What are the primary visual characteristics of radial balance?
5. What are three (3) design elements and principles that a graphic designer can use to create various degrees of visual balance in a compositional layout?
6. Name two (2) visual techniques that a graphic designer can use to create the visual characteristics of movement in a compositional layout.
7. Name two (2) types of reflective symmetry and describe the steps required to create each type in a compositional layout.
8. Describe the steps required to create the visual characteristics of rotative symmetry in a compositional layout.
9. Describe the steps required to create the visual characteristics of translative symmetry in a compositional layout.

For answers to Test your Knowledge, see [here](#).



Section 5

Layout Characteristics

The visual characteristics of compositional layout, like written and verbal communications, involves analysis, planning, organization, and ultimately problem-solving. When you write, or speak, you intuitively choose which words to use and how to use them together to effectively communicate your message. With layout, the same end result can be achieved; however, a graphic designer needs to be as intuitive.

Compositional layout is one of the fundamental elements or the “what” of a graphic designer’s visual language, whereas design principles such as layout characteristics are the “how.” When carefully considered and used together, they allow you to “speak” in an accessible, universal, visual language.

We never think of writing a sentence as an unusual or extraordinary act. We are taught at an early age about the elements and principles of written and verbal communications. Unfortunately, the same cannot be said for graphic design. However, as we were taught the basics of spelling, grammar, and syntax, we can be taught the same basic fundamentals of graphic design, including the visual elements and characteristics of compositional layout.

Layout characteristics such as pacing, sequencing, pattern, form, rhythm, flow, space, alignment, emphasis, hierarchy, and scale are all part of a graphic designer’s vocabulary and grammar for giving a “voice” and, ultimately, meaning to a compositional layout in any visual communication. Ultimately, your use of compositional layout as an effective and communicative design tool is solely dependent upon your historical knowledge, technical expertise, and a thorough understanding of its functional and aesthetic characteristics.

Pacing and Sequencing

Pacing is an essential visual and experiential characteristic that you need to carefully consider when designing multiple sequential layouts in a book, publication, or website. Print material and the digital world of websites, apps, and interfaces all require careful attention to pacing, so that a reader or user can comfortably and intuitively engage with the material presented. Compositional layouts, especially in continuous pages of publications and websites, should maintain a meaningful and thoughtful pace and sequence, so that a reader can comfortably interact with the information being presented. If it is irregular or

comfortably interact with the information being presented. If it is irregular or overwhelming, a reader will most likely become tired and frustrated and will ultimately stop reading.

A well-designed pace and sequence of layouts incorporates visual breaks, pauses, and variations to assist a reader in maintaining their interest, allowing them time to stop and consider what they are understanding and what to anticipate, as they commit to going further with the information being presented.

A graphic designer needs to remember that every creative discipline, be it dance, music, literature, film, or graphic design, relies upon rhythm, pace, and movement to engage and hold a reader's attention. A sequential series of compositional layouts for a publication or website can be designed with the same consideration in mind.

Maintaining an even and regular pacing can create a level of comfort and familiarity with a reader, just as a change in pacing can add a level of variation and surprise. Both of these visual characteristics can be achieved by increasing or decreasing the number of visual elements in a compositional layout, such as type, color, space, and imagery. The degree of restraint or freedom you employ should have a direct relationship to content, as well as to a reader's ultimate experience.

A change in visual pacing and sequencing can be used to achieve a variety of different results: to establish an obvious and apparent break between different types of content; to inject a different tone or voice to content; and to keep a reader's interest highly engaged. Every time you provide a reader with an opportunity to turn a page (printed or digital), you need to ask yourself what you want a reader to experience when that action is taken. If the same visual experience occurs every time a page is turned, you will definitely lose the interest and attention of a reader.

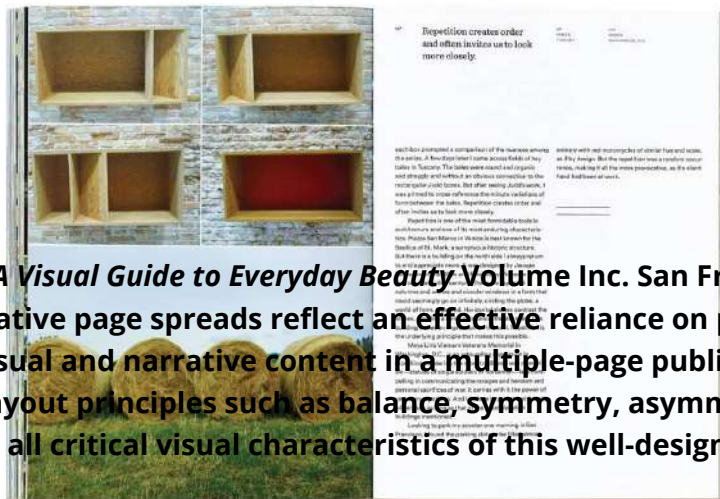

See for Yourself: A Visual Guide to Everyday Beauty Volume Inc. San Francisco, CA, USA
 These representative page spreads reflect an effective reliance on planned pacing and sequencing of visual and narrative content in a multiple-page publication. Compositional layout principles such as balance, symmetry, asymmetry, alignment, and contrast are all critical visual characteristics of this well-designed volume.

For example, the use of over-scaled type and images, unconventional cropping of images, sidebars, and informational data, as well as a reliance on full

Stopping of images, colors, and horizontal lines, as well as a contrast of bleeds of images and background colors can create variations in pace and sequence. Conversely, the use of open areas of negative space and the introduction of only type-activated pages can create a more restrained pace and sequence.

Contrast is a fundamental compositional layout principle (see *Section 4*) that is closely linked to pacing and sequencing. It is an excellent tool for directing and controlling the pace and sequence of multiple sequential layouts in a book, publication, or website.

One of the ways a graphic designer can visualize their design intent is with a comprehensive overview or plan of the pacing and sequencing of a book, publication, or website. This plan, composed of thumbnails or small-scale layouts of each page or spread, allows you to understand the overall design development of your intent prior to its finalization.

One of the most common mistakes graphic designers make today is to limit themselves by only reviewing and evaluating their work on a computer screen. You should remember not to become too dependent on what you see on screen, if the end result will be print-related. (Obviously, this rule does not apply to digital media work). Print your document several times during the design process to further confirm your decisions. The actual size, and the tactile nature, of print material are essential aspects that a graphic designer needs to understand prior to their realization.

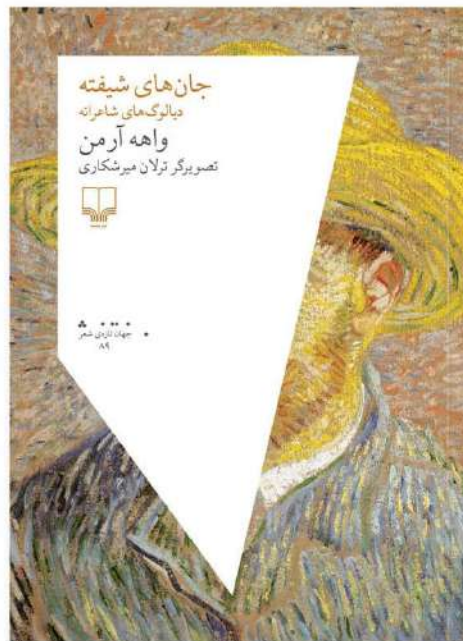

Poetry Now: The World of Contemporary Persian Poetry Studio Abbasi Tehran, IR The juxtaposition of trapezoidal-like forms layered over iconic fine art images create a series of unusual visuals, as well as reinforces the identity and theme of these publications on contemporary poetry. Each form possesses a subtle, yet different surface, shape, and edge.

Pattern and Form

Pattern and form are fundamental visual characteristics that can assist you in defining the visual quality of a compositional layout's surface activity. The visual characteristics of any pattern or form also assists a reader in seeing distinctions between one element and another in a compositional layout. Pattern is a specific type of visual texture and is traditionally derived from a defined and repeated compositional structure that always appears in an organized and regimented manner.



***It's A Beaut!* Andreina Carrillo (Student) Richard Poulin (Instructor) School of Visual Arts New York, NY, USA** This senior thesis explores the perception of female beauty in popular culture. Various patterns and forms, such as dot patterns, chevrons, and modular grids, are used throughout to reinforce distinct and separate point of views.

Historical Influences

Throughout history, pattern-making has been integral to practically every culture around the world. Patterns have been evident not only in the graphic arts, but in fine and applied arts, such as textiles, pottery, wallpaper, apparel, furniture, interiors, metalwork, ceramic tiles, mosaics, and stencils, as well as new and innovative digital experiments by contemporary artists and designers.

Additionally, artists and designers have developed a wide range of styles, forms, and motifs. Early twentieth-century innovators of pattern-making include William Morris (British, 1834–1896), Koloman Moser (Austrian, 1868–1918), Anni Albers (German, 1899–1994), Mariano Fortuny (Spanish, 1871–1949), Alvin Lustig (American, 1915–1955), Ray Eames (American, 1912–1988), Alexander Girard (American, 1907–1993), and Lucienne Day (British, 1917–2010).

In the early 1900s, with the advent of the modernist movement in the visual and applied arts, a preference for minimalist surfaces and textures became the norm, while ornate patterning and overtly decorative surfaces were avoided. This trend has been tempered and a far wider palette of choices is now evident and appreciated worldwide.

The fundamental visual elements of point, line, and shape have been the basis for creating patterns and forms throughout history. Combined with the organizational design principle of a compositional grid system, you have the potential to create an infinite number of variations. By utilizing a singular element in different organizations, configurations, and compositions, patterns and forms can be realized, with endless variations, either subtle or obvious, all being built around a singular common denominator.

Contemporary Influence:

Ludwig Hohlwein and Hermann Scherrer

Ludwig Hohlwein (German, 1847-1949) was born near Frankfurt, Germany and trained and practiced as an architect until 1906 when he became interested in graphic design. During the 1890s, he lived in Munich, where he was part of the United Workshops for Arts and Crafts, an avant-garde group of artists and craftsmen dedicated to the tenets and principles of the Arts and Crafts Movement. Hohlwein moved to Berlin in 1911 and started working as a graphic designer primarily designing advertisements and posters for the men's clothing company Hermann Scherrer.

Hohlwein's most creative phase of work was between 1912 and 1925. It was during this critical period that he developed his own unique visual style. By 1925, he had already designed 3,000 advertisements and became the best-known German commercial artist of his time.

Hohlwein's work relied mostly on the use of strong figurative elements that possessed reductive qualities of high contrast, intense flat color, and bold patterns of geometric elements. This is clearly evident in his iconographic poster for Herman Scherrer. The figurative element of the man is optically centered in the field of the poster with no apparent horizon line. The well-dressed gentleman and his riding accessories, as well as his well-bred dog, are all represented in a reductive, stark manner combined with vivid color and an abstract, black-and-white checkerboard pattern. Here, Hohlwein treats this distinctive pattern as a two-dimensional plane, in extreme contrast to the surrounding three-dimensional compositional elements, thereby creating a strong and memorable focal point for the poster.

Hohlwein's adaptation of photographic images was based on a deep and intuitive understanding of visual design principles. His creative use of color and



architectural compositions dispels any suggestion that he used photographs as the basis of his creative output. Additionally, his use of high tonal contrasts, interlocking shapes, and bold and distinctive graphic patterns made his work instantly recognizable and memorable. Hohlwein was one of the most successful representatives of the Plakastil and Sachplakat or “poster style” and “object poster,” styles in Germany during this period.

Image: ©ZHdK, Museum für Gestaltung Zürich.

Basic Pattern Types

A pattern can be a theme of recurring events or objects, which are sometimes referred to as elements of a given set. These events, objects, or elements always repeat themselves in a predictable and organized manner. Pattern has a strong relationship to geometry, since it is an organized and regimented texture in which its singular elements are composed according to a defined and repeated structure. It is due to this underlying structure that patterns are always synthetic, mechanical, and man-made, and never organic. The most basic patterns are composed through repetition and can simply be considered a visual repeat of any visual element, such as point, line, shape, or color. A single element is combined with duplicates of itself without change or modification. For example, a checkerboard is a simple pattern based on alternating squares of black and red.

Patterns can also be based on familiar elements, such as in simple decorative patterns of stripes, zigzags, and polka dots. Other patterns can be more visually complex and can be found in art and the built environment. These include patterns, motifs, and mosaics comprised of spheres, nests, arabesques, lattices, polyhedra, spirals, helixes, volutes, meanders, branching, circulation, waves, symmetry, and fractals. Moirés are also a form of pattern. They were first used after World War II, when designers began to exploit and experiment with the conventional methods and attributes of process reproduction and offset printing. The use of moiré patterns revealed to the viewer the layered tints and enlarged halftones of these processes, creating dynamic and unexpected visual effects of color and texture that had not been visually experienced before this time period. Today, digital software is an easily accessible and immediate means by which the same visual pattern effects can be achieved.



Jewish Museum Sagmeister & Walsh New York, NY, USA This rebranding program's context is based on "sacred geometry," an ancient geometric system from which the Star of David was formed, with all program elements drawn from this grid—from its custom wordmark and logotype to patterns, icons, typography, and illustrations. The program invites surprise and flexibility across all print and digital media.

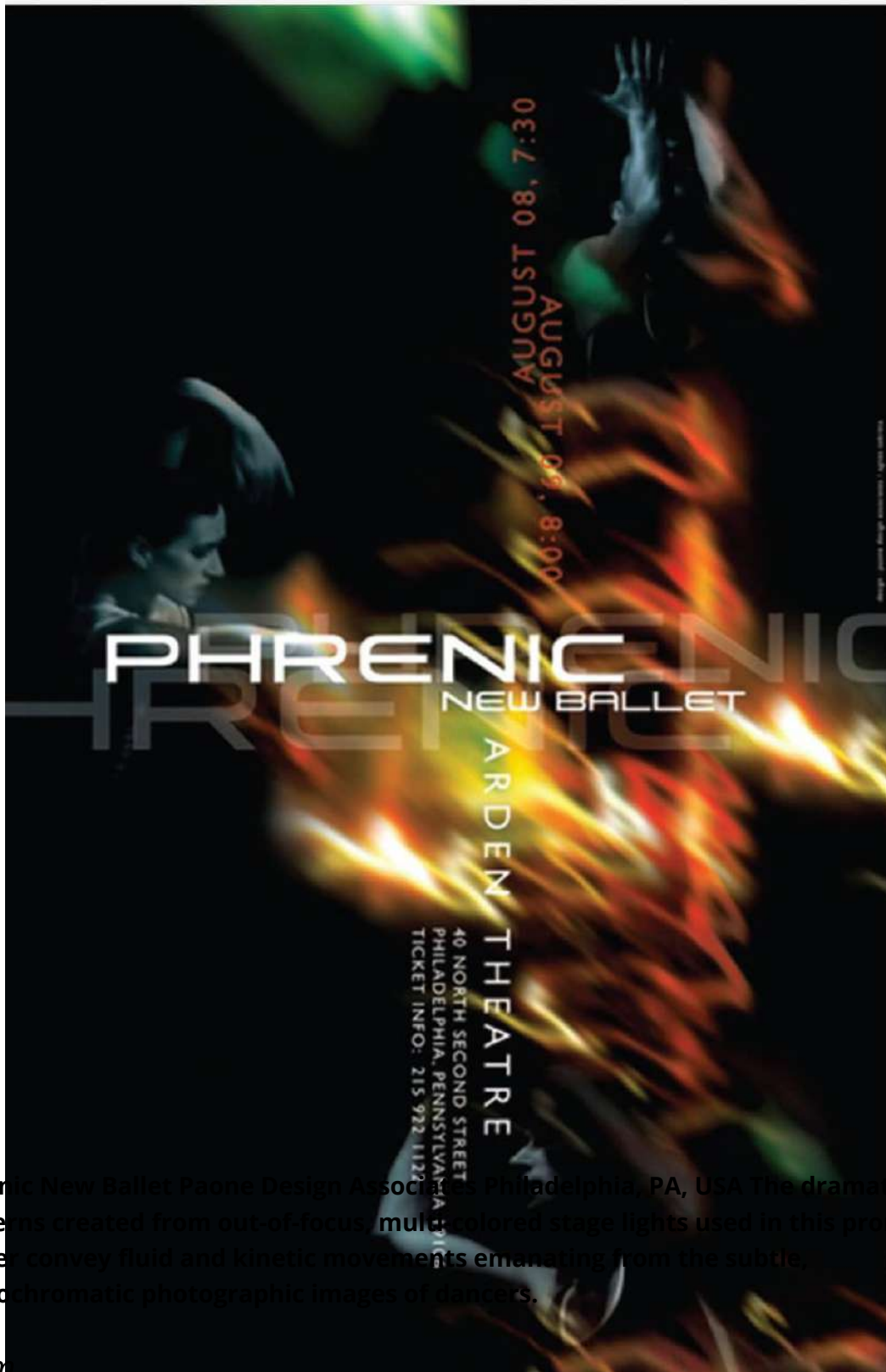

Phrenic New Ballet Paone Design Associates Philadelphia, PA, USA The dramatic, linear patterns created from out-of-focus, multi-colored stage lights used in this promotional poster convey fluid and kinetic movements emanating from the subtle, monochromatic photographic images of dancers.

Form

Form refers to the different shapes or structures of visual elements in a compositional layout, consisting of multiple surfaces and edges. It is a volume or

compositional layout, consisting of multiple surfaces and edges. It is a volume of empty space created by other fundamental design elements: points, lines, and shapes. Basic forms are derived from the most basic shapes—a square becomes a cube, a triangle becomes a pyramid, and a circle becomes a sphere.

The terms “shape” and “form” are often confused. Form is achieved by integrating depth or volume in the equation of shape. It is a three-dimensional element of design that encloses volume—it has height, width, and depth. For example, a two-dimensional triangle is defined as a shape, while a three-dimensional pyramid is defined as a form. Cubes, spheres, ellipses, pyramids, cones, and cylinders are all examples of geometric forms.

Types of Forms

Forms can be real or illusory. Real, three-dimensional form contains actual volume or physical weight, while illusory, two-dimensional form is perceptual. Real forms are three-dimensional objects, such as sculpture, architecture, and packaging. Illusory forms are illusions of three-dimensional shapes in two-dimensional spaces that occur on a printed or virtual page. These forms can be made to appear in three dimensions by using a variety of graphic conventions to achieve illusory results in any compositional layout. The simultaneous depiction of several sides or planes of a form, as opposed to only showing its flat side, is one way to create an impression of three dimensions.

Isometric and axonometric projections are examples of visualizing a form’s structure two-dimensionally without having them recede in space or varying their scale. An isometric projection is the easiest of projection methods, where three visible surfaces of a form have equal emphasis. All axes are rotated simultaneously 30 degrees away from the picture plane and kept at the same angle of projection. All lines are equally foreshortened, and the angles between lines are always 120 degrees. An axonometric, or plan oblique, projection is a parallel projection of a form viewed from a skewed direction, in order to reveal more than one of its sides in the same picture plane. In both isometric and axonometric projections, all vertical lines remain vertical and all parallel lines remain parallel.

Isometric and Axonometric Projections

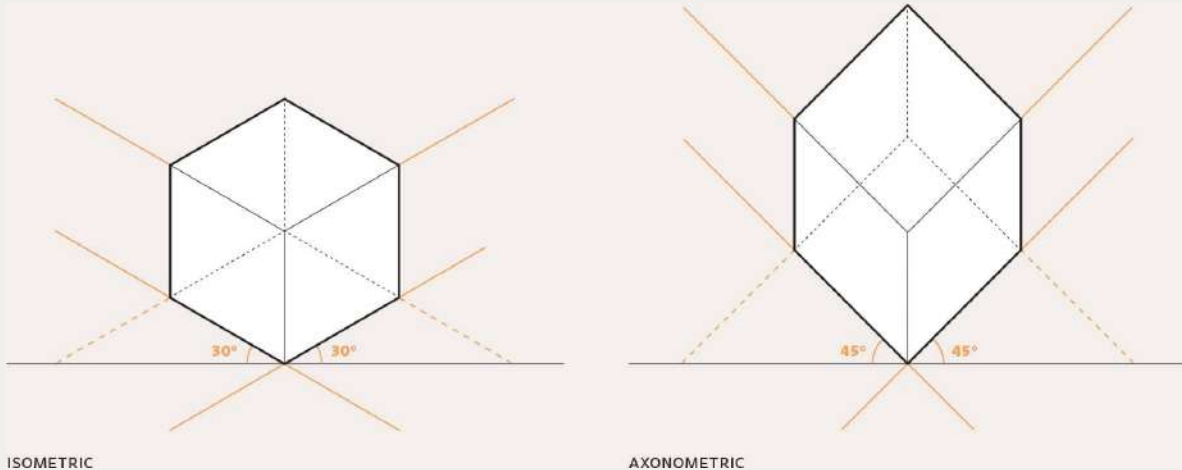

Tone, Shade, and Texture

Form can also be visually indicated in a compositional layout by the use of tone, shade, and texture. For example, the surfaces of a form curving or facing away from a directed light source appear darker than surfaces facing a directed light source. This optical effect of using tone and shade suggests the rounding of a two-dimensional shape into a three-dimensional form. The use of visual textures, such as tone and shade, as well as pattern and form, in any compositional layout provides you with a broader palette of choices for activating an area or surface of a compositional layout.

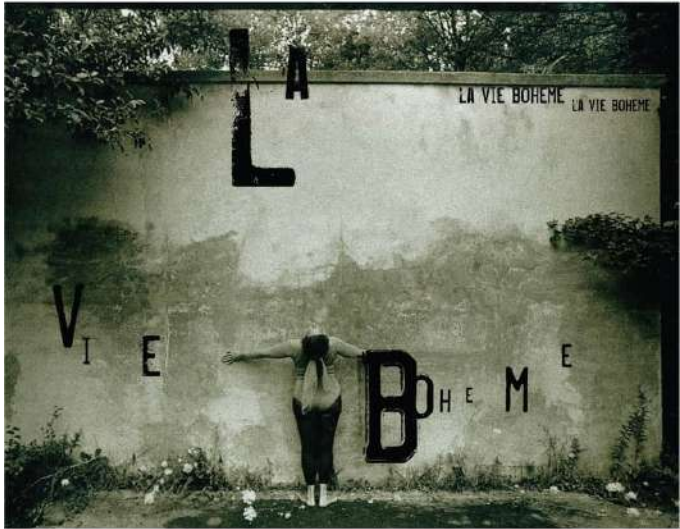

***On the Pulse of Morning* Marielle Gross (Student) Richard Poulin (Instructor) School of Visual Arts New York, NY, USA** Rhythm and flow are prominent layout characteristics of these page spreads from a poetry book that visually celebrates the themes of Maya Angelou's inaugural poem. Dramatic photographic imagery is layered with expressive typographic forms that communicate the essence and symbolism in each line of the poem.

Rhythm and Flow

Rhythm and flow are most often thought of in terms of sound and music, defined as an alternating occurrence of sound and silence. In graphic design, they can be described in the same way. Sound and silence are replaced with form and space—active and passive, primary and secondary. Creating rhythm and flow with visual elements in a compositional layout is similar to the role of choreography in dance. With visual form, choreography is the implied movement of compositional elements perceived by a reader. They are also the repetition or alternation of compositional elements, often with defined intervals located between them. They can create a further sense of movement, as well as establishing pattern and texture in a compositional layout.

There are many different types of visual rhythm, often defined as:

Regular

A regular rhythm occurs when the spatial intervals located between compositional elements, and often the elements themselves, are similar in size, length, or visual character.

Flowing

A flowing rhythm conveys a sense of movement in a layout between its compositional elements or from one page to another and is often perceived as more organic and natural in its visual character.

Progressive

A progressive rhythm is created with a sequence of compositional elements through a defined progression of steps. Rhythm and flow give character and quality to movement in any compositional layout. Visual rhythms and flows can be even-paced and static or irregular and full of exaggerated gestures.

Space

Space is an essential design element in all graphic design. However, unlike other

Space is an essential design element in all graphic design. However, unlike other fundamental elements such as line, shape, form, color, and texture, space is a visual element that cannot be placed or located in a compositional layout. It refers to the distance or area between, around, above, below, or within other visual elements, such as shapes, forms, and images, in a compositional layout. It can be two-dimensional or three-dimensional and described as flat, shallow, deep, open, closed, positive, negative, actual, ambiguous, or illusory.

It is an integral element in any two-dimensional or three-dimensional composition and can appear open, dense, compact, loose, empty, full, flat, or voluminous, depending on how it is used, organized, divided, or, in other words, activated.

Space, active or inactive, is the “glue” that holds all visual elements together in a cohesive and relevant manner in a compositional layout. You need to have a thorough and in-depth understanding of space and its visual relationships to any compositional layout. Without this insight and skill, your work will be ineffective and non-communicative.



Homero Odisea (Homer's Odyssey) Maalouf Leon el Afri (Amin Maalouf's Leo the African)
Estrada Design Madrid, ES Bold, monochromatic, over-scaled typography is used for these dual front-and-back book jackets to create active white space reinforcing each author's name and book title as iconic, singular, and immediate identifiers for both publications. Unconventional line breaks add to these highly active spaces in each composition.

Defining Space

Negative, or “white,” space refers to the empty but often active areas of a compositional layout that are void of visual elements, whereas positive space denotes areas containing visual elements, such as type, shapes, forms, and images. Varied use of negative or positive space in a compositional layout can

create an illusion of depth, specifically through the careful, established spatial relationships of foreground and background or figure-ground. When these two variables are equal, a lack of spatial depth occurs and a more visually static compositional layout is created.

For example, think of compositional space as a room in your house. The room is a three-dimensional space containing possessions or—compositional elements. Is it cluttered or is there ample room to live, work, and relax? The room is designed by filling it with objects on its walls, floors, and ceilings. The same thing can be done within a two-dimensional space by creating a compositional layout with shapes, forms, colors, images, and type.

The effective use of negative space in any compositional layout can direct a reader to the specific visual elements it surrounds, as well as indicate the layout's levels of hierarchy or importance.

Types of Space

In addition to the formal considerations of space as a compositional element, you can create specific types of compositional space to further enhance and strengthen any visual message. These are:

Actual Space

Actual space is the area that a visual composition physically occupies.

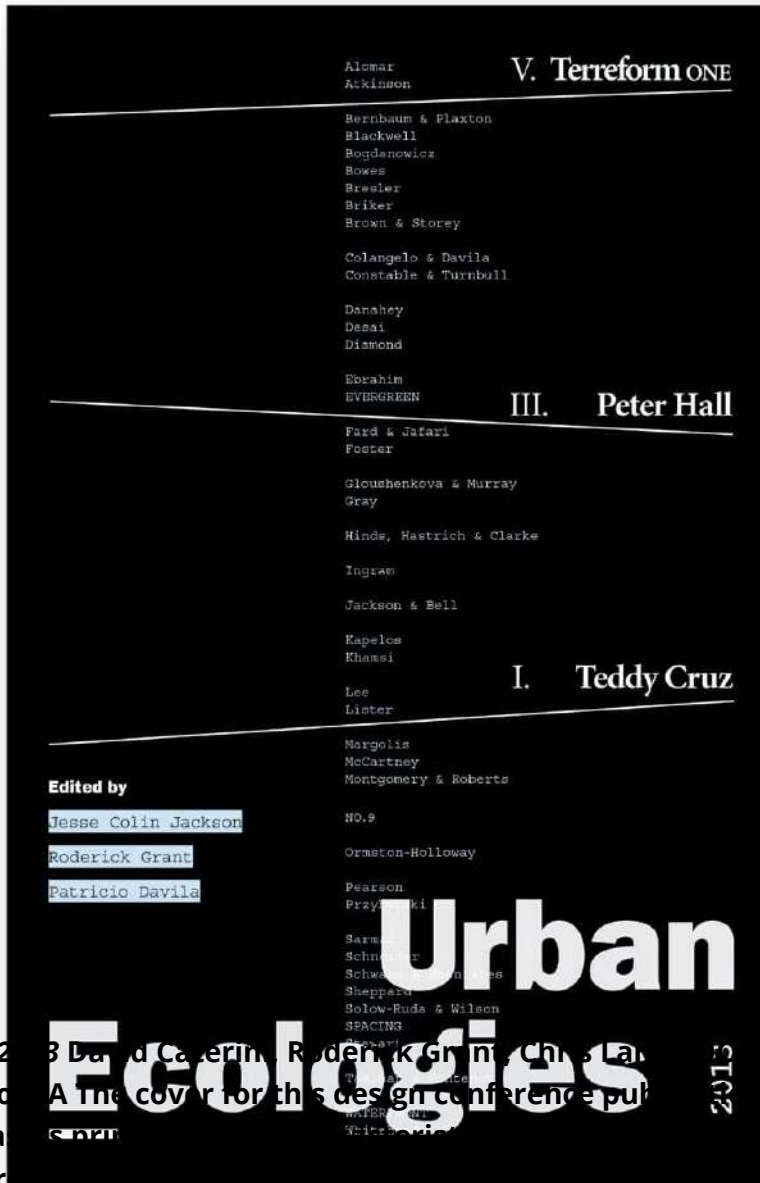

Urban Ecologies 2013 David Caverlin, Roderick Grant, Chris Lantieri, University of Toronto, Ontario, Canada. A The cover for this design conference publication reflects effective pictorial space and typographic styles and sizes that create a three-dimensional compositional space on a two-dimensional plane. The illusion of depth is further reinforced with well-established spatial relationships of foreground and background and negative and positive space.

Contemporary Influence:

Lester Beall and the Illusion of Space

Lester Beall (American, 1903–1969) was a twentieth-century graphic designer notable for being a leading proponent of modernist graphic design in the United States.

He was born in Kansas City, Missouri and later moved to Chicago, Illinois, where he studied at the University of Chicago and later at the Art Institute of Chicago. As a self-taught graphic designer, he initially designed exhibits and wall murals for the 1933 Chicago Century of Progress World's Fair. In 1935, he relocated to New York City and eventually opened his own design consultancy, located in Wilton, Connecticut.

Beall was deeply influenced by the European avant-garde and produced award-winning work in a minimalist, modernist style. Among his most recognized works is a series of public information posters that he designed for the U.S. government. The Rural Electrification Administration (REA) was one of the primary public improvement projects initiated by President Franklin Delano Roosevelt to revive a battered U.S. economy. The REA, a part of the U.S. Department of Agriculture, was responsible for promoting the use of electricity in rural areas throughout the United States. This now-classic series of large-format posters received national and international attention. All three sets of six silkscreened posters for the REA were designed and produced over a four-year period. Their graphic simplicity, combined with their flat illustrative elements was appropriate for an audience with minimal reading skills and was reminiscent of the public posters designed by the Russian Constructivists twenty years earlier. Each poster is a thorough and thoughtful study in minimalist form and compositional space.

Boy and Girl on a Fence, a poster from Series Two, is considered one of the greatest American posters of all time. It features a young boy and girl smiling and



looking to the future as they lean against a wood fence bordering their farm. Beall used flat, vibrant color, photomontage, and a juxtaposition of angled and orthogonal bands to further enhance an implied and active space in the composition of the poster. It also conveys the strong humanistic and patriotic spirit of rural America. This series is also an early example of graphic design put to work for the public good.

In 1937, Lester Beall was the first American graphic designer to be honored with a one-man solo exhibition at the Museum of Modern Art in New York City.
Image: ©Lester Beall, Jr. Trust/Licensed by VAGA, RIT Archive Collections.



Norma Neue Gestaltung GmbH Berlin, DE This striking promotional poster for Bellini's opera employs a serif grotesque typography and a black and white photographic image to create dynamic pictorial space. Optical illusion and the reader's perception of three-dimensional depth and movement on a two-dimensional plane are the poster's sole layout characteristics.

Pictorial Space

Pictorial space is the manipulation of a flat surface to create a perception of depth, movement, or direction, and relies on optical illusion to deceive the mind and eye of a reader.

Psychological Space

Psychological space is a visual composition that influences the mind and eye of a reader.

Physical Space

Physical space is the three-dimensional world. In this type of compositional space, the elemental, aesthetic, and functional requirements of space are critical considerations for any graphic designer, since they require an interface with the built environment. For example, a wayfinding sign program for an airport, an exhibition of art and artifacts in a museum, or a large-scale display for an urban retailer are all representative examples of physical compositional space.

Characteristics and Techniques

Historically, artists and designers have created a number of methods to interpret and perceive spatial depth in a composition. Compositional space in graphic design is essentially flat. It has height and width, but not depth. However, the illusion of depth and three-dimensional space in compositional layouts can be achieved in the mind, as well as the eye, of a reader by relying upon specific visual characteristics and techniques.

Relative size in spatial relationships is one of the easiest visual characteristics in creating the illusion of space in a two-dimensional compositional layout. A larger element will always appear closer in a composition than a smaller one. Overlapping in spatial relationships is another way to suggest depth in a two-dimensional compositional layout. When compositional elements overlap one another, they are perceived as if one is covering parts of the other, so that one appears in the foreground and the other appears covered and in the background of the composition.

Location in spatial relationships refers to where an element is positioned vertically in a two-dimensional compositional layout. The bottom of the composition is perceived as the foreground, the area of the composition nearest to the viewer, and the top of the composition is perceived as its background, the area farthest from the viewer. The higher an element is located in a composition, the farther back in the composition it is perceived.

For example, if you see for miles along a straight road, the sides of that road in reality are parallel to one another. However, they appear to converge and finally disappear at a vanishing point far off in the distance. It is one of the most common visual techniques for creating spatial depth, as well as a strong focal point, in two-dimensional compositions. This technique was first developed and used by Renaissance artists, where they initially plotted linear perspective lines as a base to their compositions, using them to create realistic illusions of depth in drawings and paintings of architectural scenes.

Types of Perspective

Perspective drawing is also an example of creating a form's spatial depth with two-dimensional shapes overlapping a two-dimensional picture plane. There are three types of perspective techniques that you can use to increase spatial depth in a compositional layout. They are:

Atmospheric Perspective

Atmospheric perspective in spatial relationships is another visual effect that relies on the use of elements such as color, tone, and contrast to create the illusion of space in a two-dimensional compositional layout. When compositional elements appear in the distance and further away from the viewer, atmospheric haze can obscure their visibility. This effect can be achieved by changing or modifying the visual characteristics of the composition's elements—by lightening their value, lowering their contrast, softening their edges, minimizing their detail, or muting their color. For example, increasing the blue tone of an element also creates a sense of depth in a composition since cool colors appear to recede and warm colors appear to come forward.

One-Point Perspective

One-point perspective, also known as linear perspective, is defined as the convergence of parallel lines toward a single vanishing point located on a horizon or eye-level line. Perspective lines that are located above an eye-level line are drawn diagonally down toward the vanishing point; lines that are located below an eye-level line are drawn diagonally up towards it. Vertical lines indicate height and horizontal lines indicate width; in both orientations, the lines remain parallel.



SFMOMA: Herzog Film Retrospective MendeDesign San Francisco, CA, USA These promotional posters rely on atmospheric perspective to create the illusion of three-dimensional space on a two-dimensional plane. Extreme and obvious contrasts between the foreground typography and color countered with the background duotone imagery, and coupled with a dramatic 90-degree shift in axis, reinforce the film-maker's world view.

Perspective

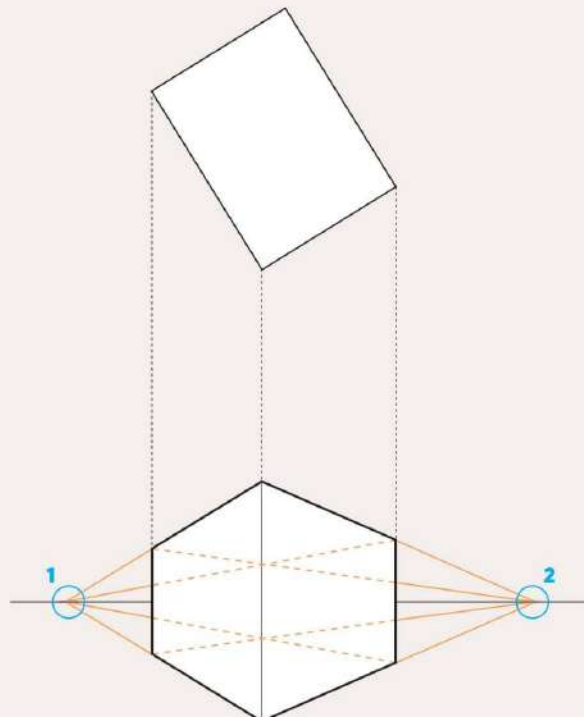
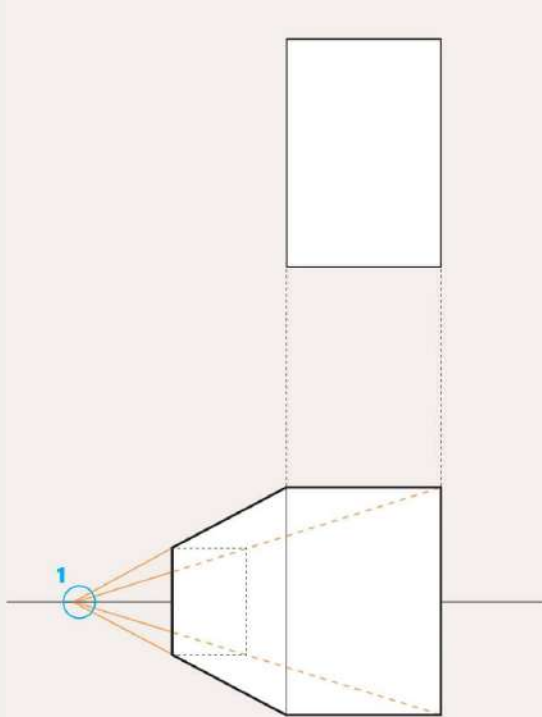
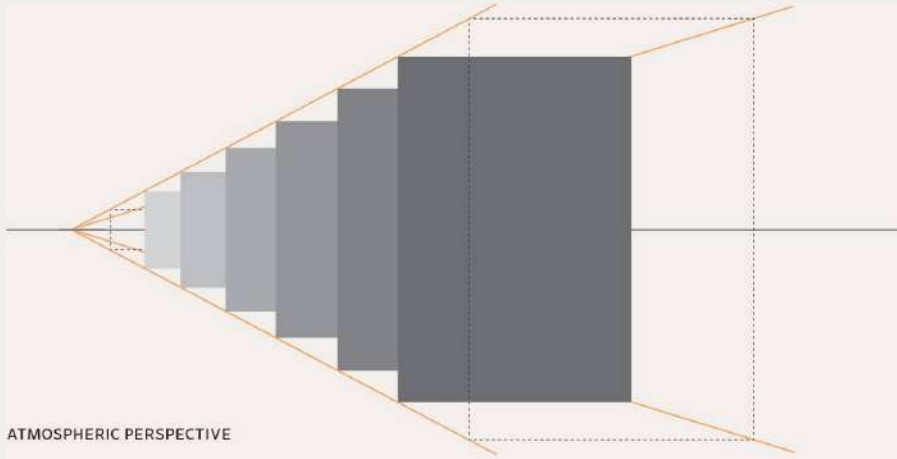



Credit Suisse Carbone Smolan Agency New York, NY, USA This extensive branding system, ranging from poster templates to standardized iconography and data visualization design standards, relies on a vivid color palette, rigorous page grids, and asymmetrical layouts with a strong flush left alignment.

Two-Point Perspective

Two-point perspective, also known as planar perspective, is where a three-dimensional element is perceived from a vantage point that always reveals a corner or another side of the element. In this example, the two visible sides of an element stretch away toward two vanishing points located in the distance on an eye-level line. Vertical lines within the composition remain parallel to one another. The remaining lines, which in reality are parallel, also appear to converge diagonally toward one of the two vanishing points located at the sides of the eye-level line.

Using these visual characteristics and techniques, singularly or in combination with each other, will strengthen the illusions of depth and space in any compositional layout.

Alignment

Alignment is a structural element and visual characteristic a graphic designer can rely upon to organize and interpret visual and narrative information in a compositional layout. For example, reading continuous narrative text in a columnar format would be difficult and somewhat chaotic without the text being organized and structured on a series of baselines, which allow a reader to interact

with the continuous flow of narrative information. Without this alignment system or baseline structure, reading and understanding would be an impossibility.



Details Blaine Pannell (Student) Adrian Pulfer (Instructor) Brigham Young University Provo, UT, USA A combination of flush left and justified typographic alignments are used throughout this magazine redesign conveying a more contemporary and varied appearance from spread to spread and section to section. These alignment formats also reinforce optimum ease, legibility, and readability for the reader.

Alignment provides a graphic designer with options for organizing and positioning visual elements in a compositional layout in relation to a fixed axis or margin. There are four basic compositional alignment formats— flush left, flush right, justified, and centered.

Flush Left

A flush left alignment is set so that all visual elements align at the same point along the left-hand vertical edge of a compositional layout. This format creates an asymmetrical composition with an even left-hand margin and an uneven or ragged right-hand margin. With type elements, a flush left alignment ensures that word spacing remains consistent, thereby optimizing readability and bringing an even visual texture and color to text settings.

Flush Right

A flush right alignment is set in the same manner, with all visual elements beginning at the same point along a right-hand vertical edge of a compositional layout. This format creates an asymmetrical composition with an even right-hand margin and an uneven or ragged left-hand margin. This alignment format is rarely used for lengthy text settings, because it reduces readability by making it difficult for a reader to identify the beginning of each line.

Justified

A justified alignment is set so that all visual elements of a compositional layout are the same length and align on both the left-and right-hand vertical edges of the layout. This is the only alignment format where all visual elements (type and image) are the exact same length, creating a symmetrical composition with even right-and left-hand margins.

Since spacing needs to be adjusted accordingly to create even left-and right-hand margins, the space between visual elements varies from line to line.

Centered

With a centered alignment, all of the visual elements of a compositional layout are centered above one another and share the same center axis with the width of the page. This alignment format creates a symmetrical compositional layout.

Advantages and Disadvantages

Each alignment format has specific characteristics, as well as advantages and disadvantages, which need to be carefully considered before you select one. Alignment formats can affect typographic spacing within any columnar text setting. When text is set in a flush left alignment, word spacing is uniform and even. The same effect occurs with flush right and centered alignments. In a flush left alignment, the hyphenation of words is necessary to prevent longer words creating an excessively ragged right-hand margin.

In a justified alignment, word spacing varies because the width of the column is fixed and the words on every line need to align with both vertical edges, no matter how many words are on each line. With justified alignments, variation in word spacing is the most challenging issue for you to resolve properly and effectively. The result of ineffective justified alignments is an overabundance of “rivers”—arbitrary negative spaces that occur and visually connect from line to line within any columnar text setting. One of many ways to solve this issue is to identify the optimum line length for the type size being used prior to creating a justified alignment. Rivers can be eliminated by one of the following methods:

Adjusting hyphenation and justification settings, also known as H&Js in most desktop publishing software applications such as Adobe InDesign, increases the number of hyphenations and reduces word spacing.

Reducing type size achieves a greater number of characters per line. Increasing line spacing creates more pronounced space between each line of text minimizing the visual appearance of rivers; decreasing line spacing makes them more apparent.

Emphasis, Hierarchy, and Scale

Emphasis, hierarchy, and scale are related visual characteristics in graphic design. Emphasis refers to the size relationships of visual elements, relative to the space they occupy in an overall compositional layout. Hierarchy and scale refer to the size comparisons of visual elements in a compositional layout, or a size relationship when comparing one element to another. These visual characteristics of a compositional layout are defined as relative, progressive classifications of proportion or a degree of size, amount, importance, and rank.

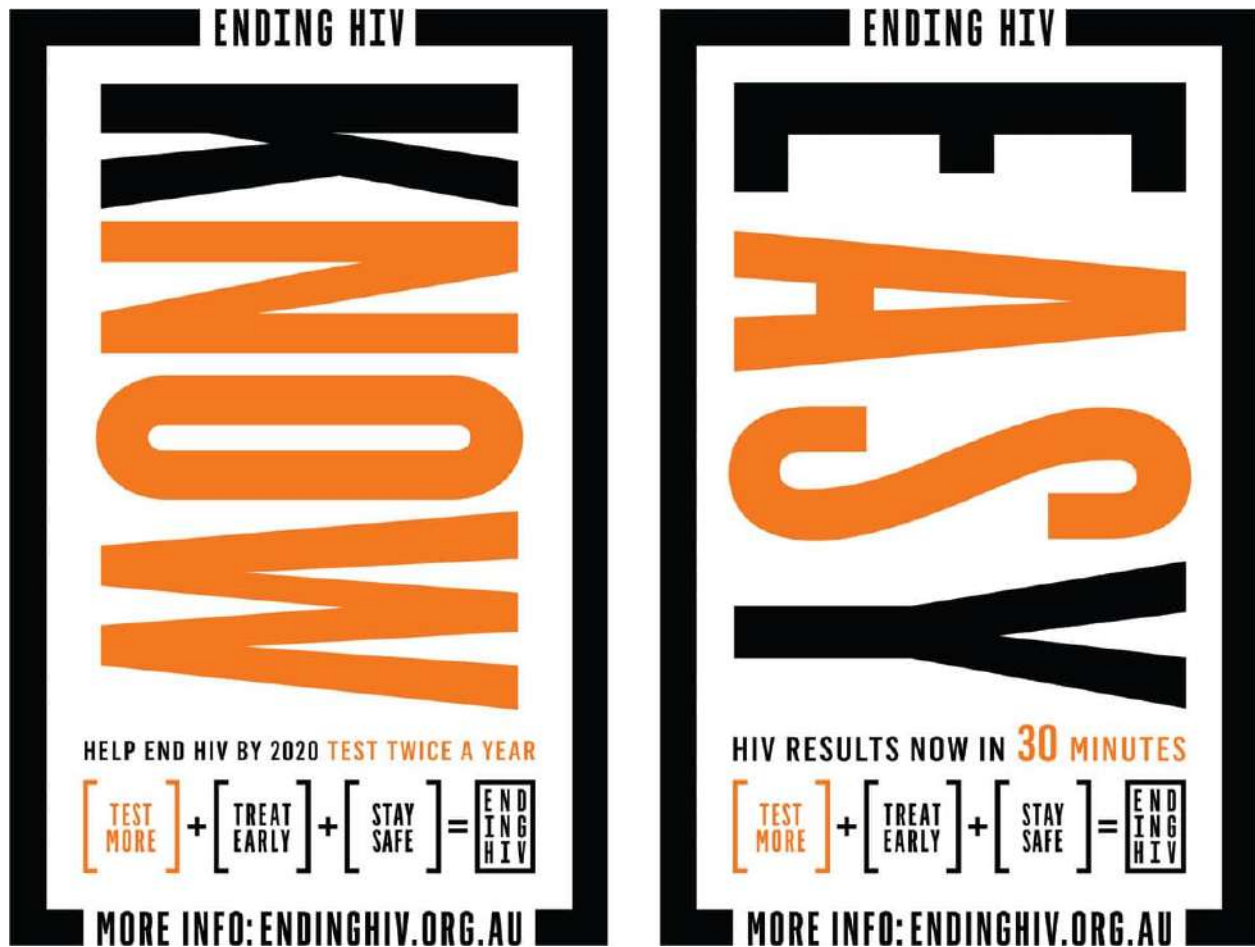

Ending HIV Frost* Collective Sydney, NSW, AUS Key messaging for this public awareness campaign uses word-within-a-word headlines set in bold, Sans Serif Neo-Grotesque all-cap typography inspired by early twentieth-century revolutionary posters. Dual messages, such as “Know Now” and “Easy As,” utilize alignment, case, color, contrast, and size paired with hierarchy and scale to create impactful messages for the public.

Emphasis

Emphasis is a fundamental layout characteristic that can be achieved by locating visual elements on a layout in locations to which the eye is naturally drawn, or by using other design principles, such as contrast, repetition, or movement to draw visual attention to it. Variation in size, white space, color, and juxtaposition can also be used to reinforce emphasis of any compositional element or an overall composition.

Emphasis is the means by which a reader can access and engage with an information hierarchy that is predetermined and designed by a graphic designer. This includes type elements such as titles or headings, subtitles or subheads, narrative text, captions, and quotes—all of which may require visual emphasis

narrative text, captions, and quotes—all of which may require visual emphasis and differentiation. Visual emphasis within any text setting can be achieved through creating differentiation with alignment, case, color, contrast, italics, mixing typefaces, position, size, white space, type style and weight, and visual cues.

Alignment

Alignment formats—flush left, flush right, justified, and centered—can establish levels of emphasis and hierarchy in any compositional layout. For example, a centered alignment of visual elements in a compositional layout can communicate a level of importance and is often used for book jackets and posters; whereas a flush left alignment of elements creates less emphasis and is often used for editorial and magazine spreads, with continuous text settings making them easier to read.

Case

The choice of either uppercase or lowercase letterforms is an effective means of creating emphasis and hierarchy within any compositional layout. Capital letterforms used selectively within continuous text settings create immediate visual differentiation and emphasis. If continuous text lines of all capital letterforms are desired, small caps in select typefaces, such as Sabon (Jan Tschichold, 1964) or TheSans (Lucas de Groot, 1994), should be considered. In both conditions, letter spacing adjustments need to be applied for optimizing readability and legibility. While an all-capital letterform setting communicates a strong sense of formality, it requires more letter spacing and ultimately more linear space than an upper and lowercase setting of the same text.

Color

Color is one of the most effective visual tools for creating emphasis and hierarchy in any compositional layout. It should be used with restraint, so that it does not create further visual confusion for a reader. When used appropriately, it can draw a reader's attention to a specific visual element or location in a layout, or lessen the visual importance of another.

Contrast

Contrast is another effective visual tool to utilize when visual differentiation or comparison is needed with complex and multilayered compositional layouts. For example, contrast in type size, weight, width, and color, as well as with the location of type within a layout and the use of multiple typefaces, further creates

visual separation and emphasis to assist a reader. Four-color process photographic images contrasted with monochromatic, black and white photographic images is another approach to effectively using contrast in a compositional layout. It can draw and direct a reader's attention, create a mood or emotion, and reinforce visual emphasis and hierarchy in any complex text setting.

As a general rule, you need to remember that more contrast can create an active and kinetic compositional layout that conveys a sense of movement to a reader, while the use of less contrast can create an inactive and restrained compositional layout that conveys a sense of calmness and stability. A compositional layout lacking contrast may result in visual monotony, neutrality, and even confusion.

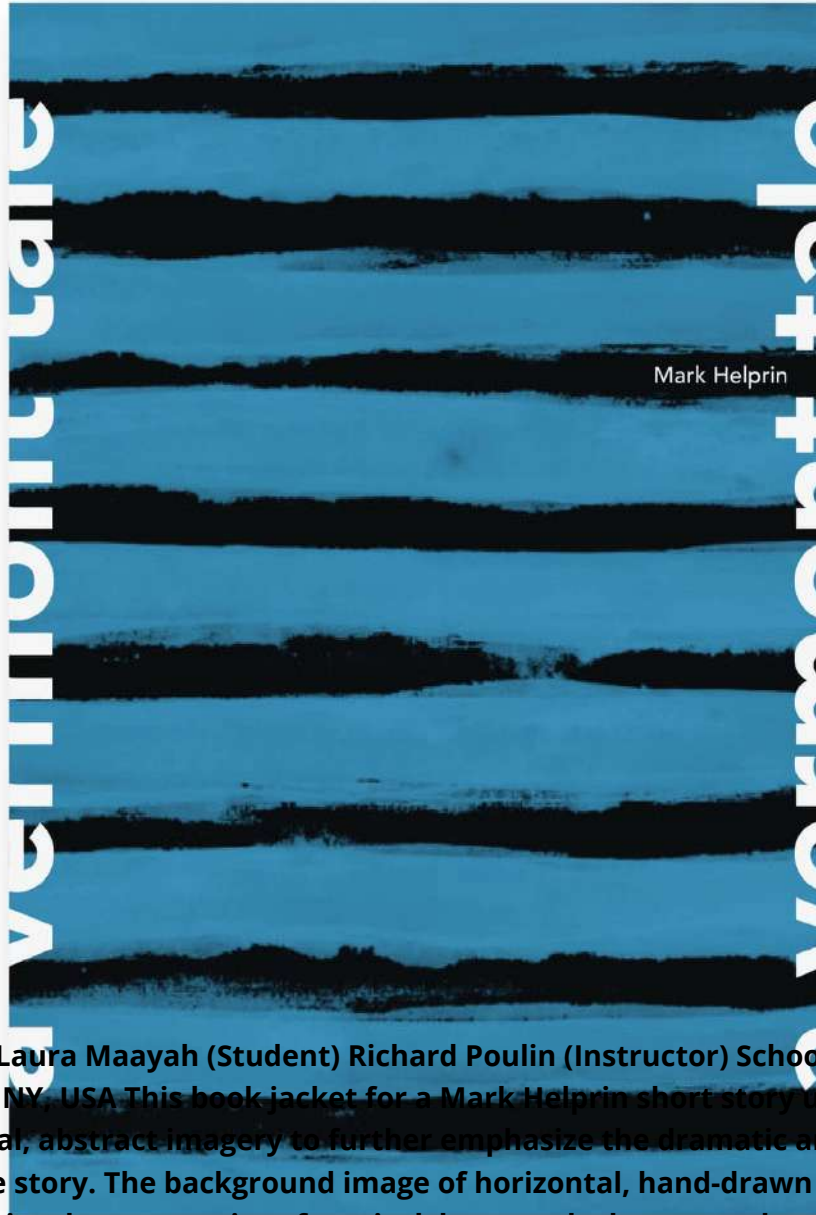

***A Vermont Tale* Laura Maayah (Student) Richard Poulin (Instructor) School of Visual Arts New York, NY, USA This book jacket for a Mark Helprin short story uses non-representational, abstract imagery to further emphasize the dramatic and emotional narrative of the story. The background image of horizontal, hand-drawn bands is framed with a visual counterpoint of vertical, large-scale, lowercase letterforms of the story's title cropped at the cover's left and right-hand edges. Both of these compositional elements collectively function as visual metaphors for the narrative themes of the story.**

Contemporary Influence:

Cassandre and Exaggerated Hierarchy

A.M. Cassandre (1901–1968) was one of the most influential poster designers of the twentieth century. Born in Kharkiv, Ukraine in 1901, Adolphe Jean-Marie Mouron (also known as A.M. Cassandre) spent most of his life in Paris following his family's emigration to France during the Russian Revolution of 1917. As a young man, he studied drawing and painting at the École des Beaux-Arts and at the Académie Julian.

Cassandre was a man of many talents and like most creative individuals he experimented throughout his life and career with a wide variety of techniques and styles. From 1922 to 1940, he devoted himself to the art of the poster. In the latter part of his life, he returned to his first love, painting, as well as the design of theatrical sets and costumes, and teaching graphic design at the École des Arts Décoratifs and then at the École d'Art Graphique.

In 1936, his work was exhibited at the Museum of Modern Art in New York City, which led to numerous cover commissions from *Harper's Bazaar*.

At an early age, the popularity of his advertising posters afforded him an rare opportunity to work for a prominent Parisian printing house. At the age of 24, he furthered his growing reputation with works such as Bucheron (Woodcutter), a poster created for a French cabinet-maker, that won first prize at the 1925 Exposition Internationale des Arts Décoratifs et Industriels Modernes. Additionally, his innovative approach for the Dubonnet wine company were among the first posters and advertisements designed so that they could be seen and read by passengers in moving vehicles.



His love of fine art, combined with his typographic sensitivity and natural ability to combine these two distinct disciplines into coherent and visually dynamic design solutions, enabled Cassandre to become one of the most successful commercial artists in the world. Inspired by Surrealism and Cubism, his posters are memorable for their innovative graphic solutions and their frequent references to twentieth-century, avant-garde painters such as Max Ernst and Pablo Picasso.

L'Atlantique is a primary example of how Cassandre used scale as a dynamic compositional element in all of his work. The poster is a composition of symmetrical elements with an extreme upward angle that emphasizes the ship's monumental scale and Art Deco lines. It is composed in such a manner that forces our eyes to be irresistibly drawn upward to the sky. The immense scale of the ship's prow is further emphasized by the presence of a small tugboat on the horizon line where ship meets sea. This upward movement is further reinforced by steam coming from the tugboat's smokestack spiraling upward and becoming one with steam coming from the ship's smokestack. This reductive, erect composition towers over the monolithic text L'ATLANTIQUE that also functions as a stable, typographic pedestal for the image of the ship.

The majority of Cassandre's posters were based on a true sense of proportion and scale, which governed their overall final composition. His primary objective was always to make the object the center of a poster's attention. Through exaggerated scale, he was able to celebrate the geometry of form, as well as use this fundamental design principle as a memorable, attention-getting, storytelling device.

Image: ©Mouron Cassandre.

Italics

Italic type is defined as a script-like or slanted version of a roman typeface angled to the right and often used for emphasis. When italic type is used within a compositional layout, as in any text setting, it allows a reader to immediately understand and connect with visual emphasis and differentiation. Italics are also used to convey the spoken word and are traditionally used for quotations or words in other languages.

Mixing Typefaces

Many typefaces and typeface families available today offer a wide range of weights, widths, styles, and character sets that provide you with a multitude of options for creating visual emphasis and hierarchy. Visual distinction and

appropriateness need to be carefully considered when using more than one typeface within any given work. For example, the inherent contrast between serif and sans serif typefaces may be more visually effective and immediate than using two serif or sans serif typefaces.

If two typefaces occur on the same baseline, they will be more visually unified and related to one another if they share a common x-height measurement. This approach will also create an ease of readability in any text setting that relies upon more than one typeface.



***Underground Architecture* Yu Rong (Student) Kathrin Blatter (Instructor) Academy of Art University San Francisco, CA, USA Posters for a hypo-thetical architectural exhibition explore underground architectural spaces such as a wine cellar, a bomb shelter, and a subway, integrating the words "safe," "calm," and "link," respectively. All three posters effectively emphasize these themes with large-scale, three-dimensional letterforms that convey an archi-tectonic visual effect in a unified manner.**

Position

The activated spatial position of each visual element in a compositional layout, as well as the white space occurring or framing each of these elements, is equally important to a reader engaging with, and understanding, this information hierarchy. Specific positions on a page layout can emphasize, as well as communicate, an information hierarchy. For example, the lower area of a composition is often perceived as the foreground of the picture plane, which is closest to a reader, whereas the upper area is perceived as the background of the picture plane.

Additionally, different types of text information, such as headers, footers, captions, footnotes, and page numbers can have specific locations that communicate their level of importance, as well as reinforcing a given hierarchy.

Size

It is important to remember that size and scale are not the same concept. They differ in that size is based on specific spatial dimensions, whereas scale is relative and based on proportion.

The differentiation of content within a compositional layout can also be achieved by variations in type sizes. For example, a title, subtitle, introductory paragraph, or pull-quote can be set in a larger size to create visual emphasis. Specific words or phrases occurring within continuous text can also be set at larger sizes for emphasis and visual immediacy, if needed.

A reader's eye will naturally go to the largest-sized visual element first. While you may rely upon conventional locations for titles, headlines, and footers, a well-designed layout with an intuitive emphasis and visual hierarchy will guide a reader's eye through the correct sequence of appropriate compositional elements, no matter what they are and where they are located.

White Space

The use of white space, also known as negative space, in any compositional layout can create visual emphasis as well as drawing a reader's eye to a specific location. Providing a reader with ample white space reinforces the ease and accessibility of any visual element, type or image.

For example, adding vertical white space in the form of a one-line or half-line space above or below a heading or subheading separates it from a continuous narrative text, creating visual emphasis.

Type Style and Weight

The majority of typefaces are available in a range of weights, from the most universal roman or book weight that is found in most digital text type font sets to weight variants such as light, medium, bold, black, and heavy. When selecting a particular typeface for a compositional layout, careful considerations should be given to its style and weight, so that it can accommodate a variety of informational needs relating to visual emphasis and hierarchy. For example, continuous text settings with titles and subtitles may require visual separation and emphasis for a reader.

While conventional solutions traditionally rely upon bold or distinctive typefaces to meet this need, the counterpoint to these conventions, such as the reliance upon lighter versions of a text typeface, can be equally effective when set correctly and appropriately.

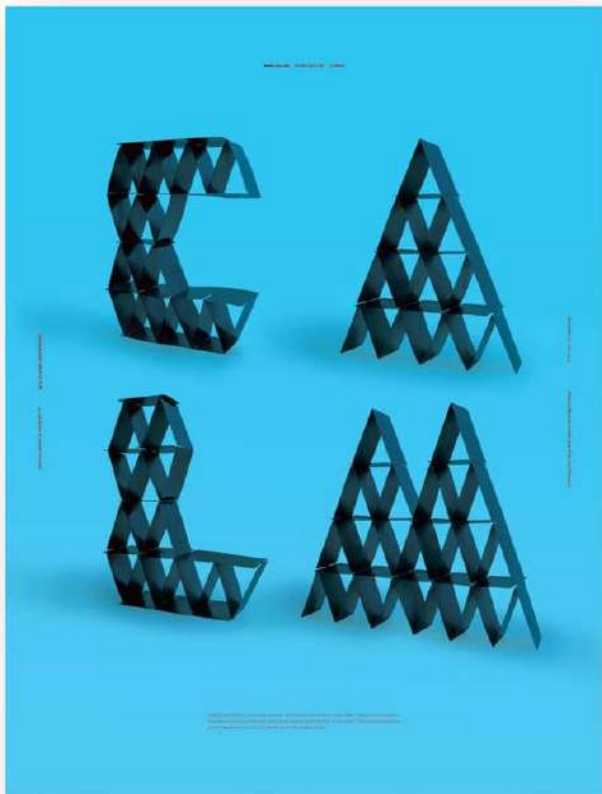

***Underground Architecture* Yu Rong (Student) Kathrin Blatter (Instructor) Academy of Art University San Francisco, CA, USA**



OzHarvest 2013 Frost* Collective Sydney, NSW, AUS Over-scaled, all-cap typographic elements, combined with the unconventional use of a Decorative Sans Serif display typeface with distinctive rounded terminals, establishes emphasis, hierarchy, and visual scale throughout both print and digital applications of this annual report.

Visual Cues

There are numerous ways in which you can create and clearly communicate visual hierarchy and organization in a compositional layout. For example, when type is used effectively to communicate the organization of narrative content, a reader can easily access this information in an intuitive manner. Visual cues, when used consistently and appropriately in a multifaceted and layered text setting, can assist a reader in the most meaningful way. Visual cues include indents, line spacing, type style and weight variations, as well as variations in

type size and color.

Although they are related, emphasis and hierarchy are distinct visual characteristics that give importance and value to specific visual elements in a compositional layout by directing the attention of a reader's eye.

Hierarchy

The visual characteristic of hierarchy is a logical and visual means to communicate the relative importance of different visual elements in any compositional layout. It is a visual guide to their organization and to the level of importance you allocate to each compositional element, reinforcing meaning and assimilation of a message. A compositional hierarchy can make a layout clear and easier for a reader to understand by utilizing size, space, and color effectively, in a meaningful and appropriate manner.

For example, a well-designed typographic hierarchy provides clear visual cues that guide a reader through narrative content that further guarantees they will engage with, and more importantly, understand the message being communicated.

Scale

As referenced above, it is important to remember that scale and size are not the same concept. They differ in that scale is relative and based on proportion whereas size is based on specific spatial dimensions. The visual characteristic of scale in a compositional layout can be categorized as either objective or subjective:

Objective Scale

Objective scale is defined as the actual dimensions of a physical element, object, or space, or a literal relationship between that actual element, object, or space and its graphic representation. For example, objective scale is used in an architectural drawing of a building that is drawn to a specific scale on a specific-sized sheet or paper plot, at a size much smaller than the actual building.

This type of scale is not only used in architectural and construction drawings, but in maps and models. These "scaled" graphic representations are drawn in a quantifiable ratio that is defined numerically as two quantities separated by a colon (:). For example, a drawing scale defined as 1:100 means that one unit of measurement (such as inches or meters) on that drawing represents one hundred (100) of the same units at full size. Full-scale is defined as actual size.

Subjective Scale

Subjective scale refers to a person's impression of an actual element, object, or space. For example, a car or a house may be described as having an immense or intimate scale, due to how it relates to our physical selves, as well as our knowledge and familiarity with cars and houses. This type of scale is relative only to our own personal experiences and is, therefore, subjective in nature.

Effective Use of Scale

Scale can be used as an effective visual characteristic to create variety, emphasis, and hierarchy in any compositional layout. A proper use of scale contributes to the stability and visual comfort of any composition, while an incorrect scale will create an uncomfortable and confined awareness in a composition.

An element, such as an image or typographic headline within a compositional layout, can appear larger or smaller depending on the size, placement, color, texture, and visual weight of the elements around it. Additionally, contrast in size can create visual emphasis, hierarchy, depth, movement, and tension within any compositional layout.

When compositional elements are all the same size, a layout will appear flat, one-dimensional, and lack contrast, tension, rhythm, and movement. It's as if we were listening to music and heard only one, continuous, monotonous note—always the same, never fluctuating in tone or resonance. All of the previous layout characteristics referenced, when used effectively and meaningfully, can create a sense of depth and movement in any compositional layout. Scale is also a critical consideration in achieving this end result.



***Angels in America* John Gilmore (Student) Richard Poulin (Instructor) School of Visual Arts New York, NY, USA This poster's layout characteristics employ emphasis, hierarchy, and scale to bring the reader's eye directly to the symbolic "light" of the background photographic image. Varied scale letterforms fragmented in unconventional breaks create a visual frame that guide the reader's eye to the poster's focal point within the overall composition.**

Scale can be used to direct a viewer through a singular design element, as well as a layout of multiple visual elements.

You also need to consider scale in practical and functional ways. Professional work today requires graphic designers to consider a variety of different media and vehicles for conveying their work. From the traditional realms of printed matter, to the small-scale requirements of the virtual world of websites and electronic interfaces, and the large-scale requirements of environmental graphics and exhibitions, scale is an important and constant consideration.

On a day-to-day basis, we all make scale comparisons relating to size

On a day-to-day basis, we all make scale comparisons relating to size, distance, and weight. These types of visual comparisons are usually based on known and familiar experiences that constantly provide us with a visual reference or orientation. For example, a skyscraper or snow-capped mountain range seen on the horizon may be difficult to judge in terms of size. However, when we juxtapose either of these with a familiar scale reference, such as a human figure, a car, or even a book, it is an easier task for us to immediately quantify and understand.

¶

Test your Knowledge

1. What are two (2) distinct methods for achieving visual pacing and sequencing in multiple compositional layouts?
2. Name three (3) distinct types of patterns that can be used in compositional layouts.
3. What are the primary visual characteristics of real and illusory forms in a compositional layout?
4. Describe the visual characteristic of an isometric projection?
5. Describe the visual characteristic of an axonometric projection?
6. What are the primary visual characteristics of regular, flowing, and progressive visual rhythms in a compositional layout?
7. What are the primary visual distinctions of actual, pictorial, psychological, and physical spaces in a compositional layout?
8. Describe the visual characteristic of atmospheric perspective.
9. Describe the visual characteristic of one-point or linear perspective.
10. Describe the visual characteristic of two-point or planar perspective.
11. What are the four (4) basic compositional alignment formats used in compositional layout?
12. Describe the primary visual characteristics, and the advantages and disadvantages, of each alignment format.

13. Name the primary methods for achieving emphasis in a compositional layout.
14. What are the primary visual characteristics of subjective scale and objective scale?

For answers to Test your Knowledge, see [here](#).



Section 6

Layout in Practice

In everyday occurrences and interactions, we hear someone say that they have “expressed their opinion.” Visual expression or communications is something more concrete, more specific, more objective, and more intentional than that. Meaningful and memorable graphic design occurs when its fundamental elements and principles, such as compositional layout, are used selectively and collectively, to create a “visual experience” for the reader.

Expression is a design principle fully dependent on your own creativity, imagination, individual ideas, moods, sole emotional outlook on the world, and their place within the world. It is perceived visually, as well as psychologically, in any visual message. It is a completely subjective principle and reflects directly on the time in which you have lived and the experiences you have had. Expression cannot be taught; it is learned by each and every graphic designer. It is also a reflection of your inner thoughts, dreams, fears, and passions. As a result, an inherent bias completely depends upon separate experiences or realities that ultimately influence your own creative process, choices, and work.

Since the beginning of human development, we have had the desire, as well as the basic need, to express ourselves. While graphic design as a discipline has had a relatively short history, with the term “graphic design” first coined by renowned type designer, calligrapher, and book designer William Addison Dwiggins (American, 1880–1956) in 1922, visual communications, including the fundamental design principle of compositional layout, has always been an integral part of our human history. It is clearly evident in the rigorous organization and lines of hieroglyphics on the walls, surfaces, and passages of Egyptian pyramids (ca. 3200 BCE); the figurative and typographic Byzantine mosaics in the Church of Sant’ Apollinare Nuovo in Ravenna, Italy (ca. 549); the illuminated medieval manuscripts and incunabula of the Middle Ages (ca. 600–1600 CE), and in the multi-columnar grid of the *Times* of London (ca. 1932).

Graphic design provides a means for you to express your own imagination in ways that do not rely solely upon narrative or visual language. Every element used in graphic design, such as compositional layout, has the potential to express something specific. Although the explanation and ultimate use of design elements and principles may seem cut and dried, the quality of these design elements and principles is perceived solely through the expression of the total

message created by a graphic designer.

Compositional layout is one of the most powerful forms of visual expression and communications. When used in combination with image, color, and other relevant design elements, it can convey a memorable and timeless message that will always be associated with a specific human emotion.

This section not only explores the graphic design student experience; it includes work by some of the most successful and renowned graphic design practitioners from around the world and how they have applied these fundamental principles of compositional layout to their work. By examining both student and professional work, *Design School: Layout* is also a more meaningful, memorable, and inspiring reference for graphic design students, as well as for novice practitioners starting their professional careers.

The following pages provide visual references you can fully embrace, and will act as a catalyst for exploring new concepts, technologies, materials, and styles with confidence and assurance. Hopefully this book will also help you achieve a greater power and influence—a power to inform, educate, and/or persuade a single person or collective audience in a meaningful and memorable way—through layout.

Grid Systems Symmetrical



Kakamura Keith Haring Collection Hinterland New York, NY, USA This dual language book investigates the connections between Keith Haring—an artist and social activist whose work responded to the New York City street culture of the 1980s—and Japanese culture by employing minimalist typography organized in a symmetrical columnar grid with two alignment formats: flush left for English and justified for Japanese.



IDLEWILD

The book is a series of high-contrast, black-and-white photographs of the Idlewild airport, showing the terminal, the tarmac, and the surrounding landscape. The images are arranged in a grid-like fashion, with some larger than others. The text '1947' and 'IDL' is positioned to the right of the main image area.

The job is a constant experiment. Each interior building is a new, a prototype, a prototype of architecture in its own right. It is a new way of thinking about space, a new way of thinking about light and color, a new way of thinking about the human experience of space. It is a new way of thinking about the human experience of space.

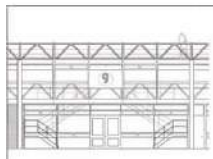

LGV

The book is a series of high-contrast, black-and-white photographs of the LGV airport, showing the terminal, the tarmac, and the surrounding landscape. The images are arranged in a grid-like fashion, with some larger than others. The text '1950' and 'LGV' is positioned to the right of the main image area.

LOVE FIELD

The book is a series of high-contrast, black-and-white photographs of the Love Field airport, showing the terminal, the tarmac, and the surrounding landscape. The images are arranged in a grid-like fashion, with some larger than others. The text '1950' and 'LGV' is positioned to the right of the main image area.

LUV



PITTSBURGH

The book is a series of high-contrast, black-and-white photographs of the Pittsburgh airport, showing the terminal, the tarmac, and the surrounding landscape. The images are arranged in a grid-like fashion, with some larger than others. The text '1950' and 'LUV' is positioned to the right of the main image area.

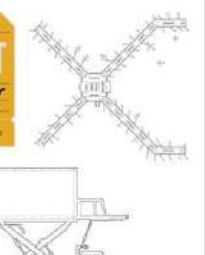

Architecture Boston Stoltze Design Boston, MA, USA These page spreads are representative of the extensive variations in compositional layouts found in this quarterly magazine on architecture and urban design. A flexible, symmetrical page grid system with diverse typographic styles, weights, and glyphs add visual nuance in a unified and integrated manner.



Papier 14, 15, and 16: foire d'art contemporain Jolin Masson Montréal, QC, CA
Symmetrical page grids are used extensively throughout this visual identity to visually reinforce a modern and accessible brand. This page grid type provides maximum flexibility and continuity, allowing for diverse narrative and visual content to be treated in a meaningful and accessible manner for the reader.

Grid Systems

Modular



L'Observatoire Triboro Brooklyn, NY, USA The horizontal and vertical columns of this well planned and conceived modular grid system, coupled with its distinct fields and spatial zones, provides an efficient methodology for creating multiple layouts with visual consistency and variation for this lighting design studio's website and identity program. Modular grids, such as the one used here, also accommodate for complex, multi-faceted narrative and visual content which is an essential feature of this website.

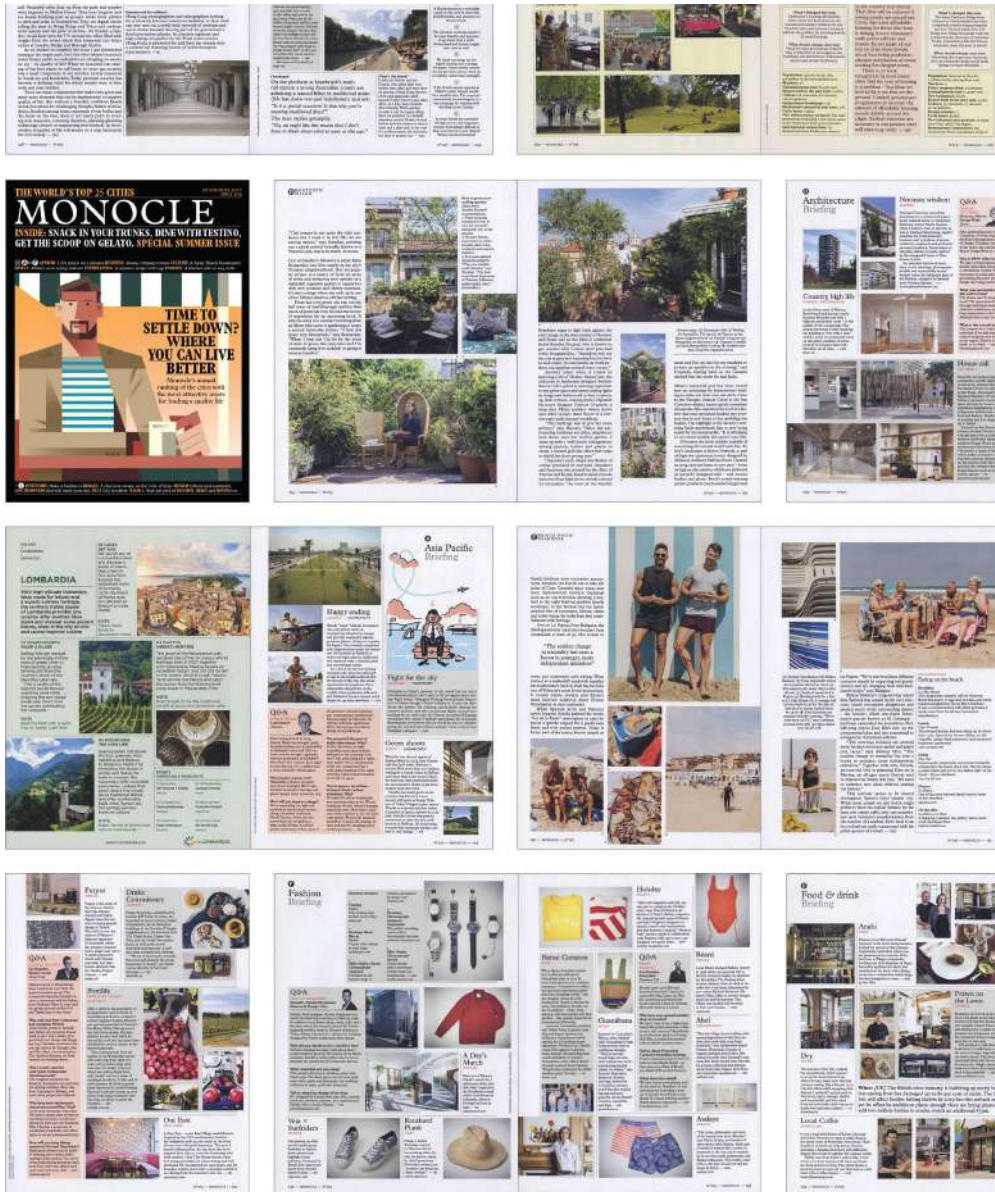

Monocle Richard Spencer Powell (Creative Director) London, UK This magazine's reliance on a compound modular page grid provides flexibility, variation, and precision for continually creating a diverse series of page layouts for narrative and visual content on a month-to-month basis. This functional feature of modular grids adds order, clarity, and an urban visual spirit to this publication, as well as its overall brand.

Grid Systems
Asymmetrical

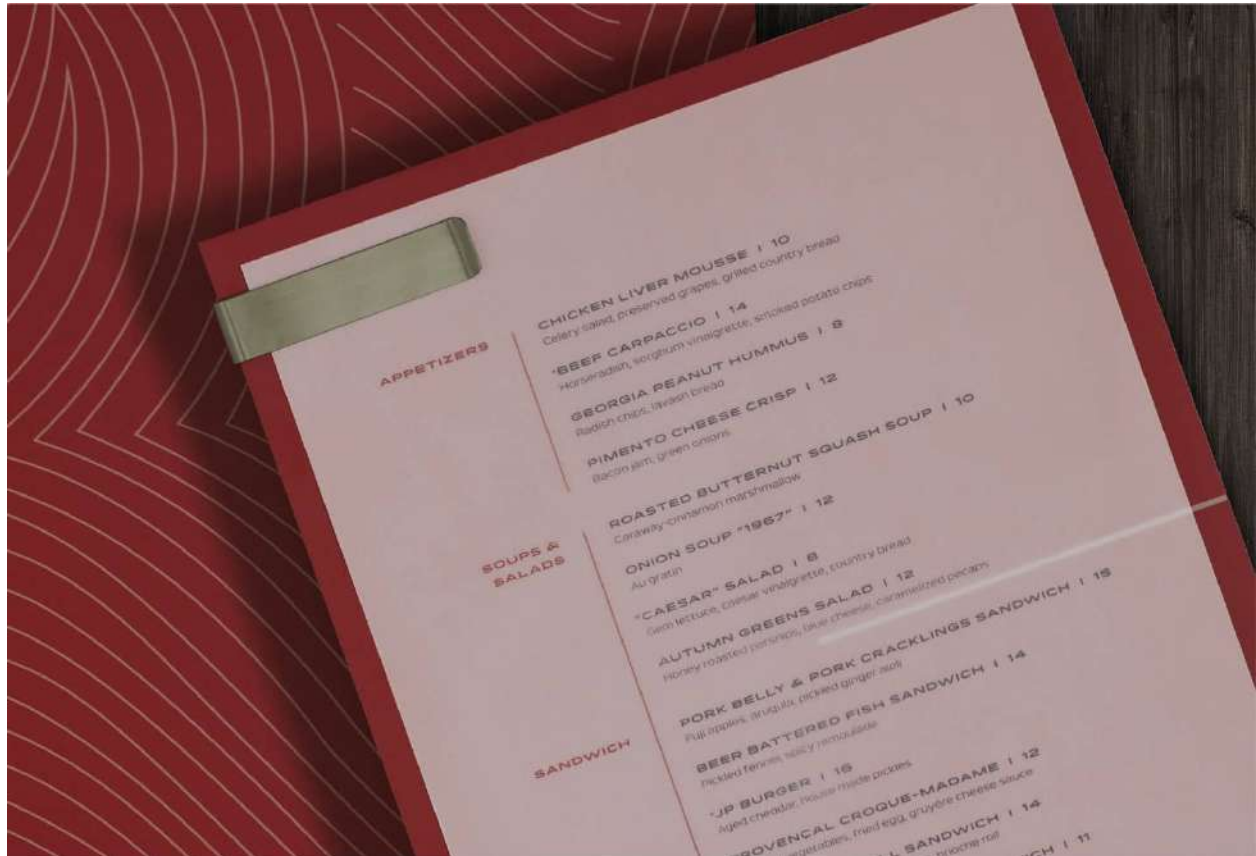

JP Atlanta Restaurant Poulin + Morris Inc. New York, NY, USA A two-column, asymmetrical grid is utilized for the organization of this set of breakfast, lunch, and dinner menus. The narrower, left-hand column lists the overall menu offerings such as appetizers, salads, soups, and entrees with a wider, right-hand column listing detailed menu offerings of each.



***Sculpture In Istria* / Studio Sonda Vizinada, HR An asymmetrical page grid is used throughout this publication, the first in a six-book series on the artistic heritage of Istrian churches. A dynamic page grid provides a left-hand column with ample line length for continuous narrative text and a narrower right-hand column for captions.**



Architecture in Formation Atelier Pastille Rose Montréal, QC, CA These representative page spreads from a digital architecture manual that bridges theory and practice, are composed with an asymmetrical columnar page grid system. The grid is comprised of three equal measure columns with two columns accommodating continuous narrative text and the third containing caption and reference information. On select pages, all three columns are used for shorter continuous text to create dynamic white space intermittently located throughout the publication.

Grid Systems Baseline

APOSTROPHE In English, the apostrophe serves three purposes: the marking of the omission of one or more letters (as in the contraction of do not and don't), the marking of possessive case (as in the eagle's beak), or one month's (and), and the marking by some as plural of written forms that are not nouns, abbreviations or dates (as in P's and Q's and single numbers as in 7's).	PERIOD The full stop (in British English) or period (in American English) is a punctuation mark placed at the end of a sentence. The full stop sign is sometimes called a baselinestop because, typographically, it is a dot on the baseline. This term distinguishes the baselinestop from the interpoint (a raised dot). It ends a sentence or an abbreviation. There is a lot of confusion about the exact placement of this punctuation mark. In case of an entire sentence in block, the period is placed before the closing bracket. If the sentence ends with a word or several words in brackets, however, the full stop is placed after the closing bracket (and not before). The same principle goes for quotation marks. If a sentence ends with a quotation mark, then the period is placed after the quotation. If the entire sentence is quoted, then the period comes before the closing quotation mark.	COLON It's a punctuation mark consisting of two equally sized dots centered on the same vertical line. A colon is used to explain or start an enumeration. A colon is also used with ratios, titles and subtitles of books, city and publisher in bibliographies, Statute citations between chapter and verse, and—in American English—in separate hours and minutes, for business letter salutations and in formal letter-writing.	BRACES Curly brackets—also called braces—are used in specialized ways in poetry and music (to mark repeats or joined lines), in music (musicians correct two or more lines of music that are played simultaneously; in mathematics they connect sets, and in writing, they may be used similarly, as in Select your animal (pigeon, sheep, cow, horse) and follow red), in many programming languages, they enclose groups of statements.	BACKSLASH It's a typographical mark used mainly in computing and is the mirror image of the common slash (/).
QUOTATION MARKS In English these marks are placed in pairs around a word or phrase to indicate quotation or direct speech (as in Carol said "Go ahead" when I asked her if the launch was ready) mention in another work of a title of short or subsidiary work (like a chapter or episode, as in "Troncycle of Ferguson" was the pilot episode of Star Trek: The Next Generation), used to express irony (as in The "best" apples are full of worms). The pair of quotation marks consists of an opening and a closing quotation mark. The important rule is that the style of opening and closing quotation marks be matched. For a question mark within a quotation, a different solution must be found, and the most elegant one in this case is using the single quotation marks as the second set (as in "a quotation 'within' a quotation").	SEMICOLON It serves two purposes: it is used to indicate connection between two independent (but related) clauses. It is used in lists that have internal punctuation. After each part of the list, a semicolon is inserted and the last part is closed off with a period. In a list that consists of single words, the semicolons are omitted, as in the period. If parts of the list start with a capital letter and consist of complete sentences, each part of the list ends with a period.	EXCLAMATION MARK It's usually used after an interjection or exclamation to indicate strong feeling or high volume (shouting as in Work out!) and often marks the end of a sentence. A bare exclamation mark (with nothing below or after) is often used in warning signs. It is placed, with no space, at the end of a sentence. In text an exclamation mark is sometimes combined with a question mark to indicate that the question should be asked with emphasis.	UNDERSCORE It's a line that lies slightly below the baseline and has the same length as the an dash. This line is often used in text of warnings.	AMPERсанд An ampersand is a logogram "8", representing the conjunction word "and", though to save confusion it is called a symbol. It originated as a ligature of the letters A and S for "and".
DAGGER OR OBELISK It's a typographical symbol or glyph. The asterisk is used to call out a footnote, especially when there is only one on the page. Less commonly, multiple asterisks are used to denote different footnotes on a page (A, 1, **, ***). Three spaced asterisks combined on a page may represent a jump to a different scene, thought, or section.	ELLIPSIS Three consecutive dots that usually indicate an intentional omission of a word, sentence or whole section from a text without altering its original meaning. Depending on their context and placement in a sentence ellipses can also indicate an unfinished thought, a long pause, a slight pause, a hesitant or echoing voice, or a nervous withdrawal of speech. Appearance is the use of an ellipsis to talk off the subject (as in but I thought he was...), when placed at the end beginning or end of a sentence, the ellipsis can also imply a feeling of melancholy or longing.	QUESTION MARK It indicates an interrogative clause, or phrase. It is usually placed at the end of a sentence, with no space between the last word and the mark. It replaces the full stop. If a question mark is used, the same rules apply as the period.	ASTERISK It's a typographical symbol or glyph. The asterisk is used to call out a footnote, especially when there is only one on the page. Less commonly, multiple asterisks are used to denote different footnotes on a page (A, 1, **, ***). Three spaced asterisks combined on a page may represent a jump to a different scene, thought, or section.	AT-SIGN It's originally an accounting and commercial invoice abbreviation meaning "at a rate of" (eg. 7 widgets at \$2 x 14). Nowadays it is largely used in email address and computer programming.
BRACKET Are mainly used to insert explanatory material or to mark where a passage was omitted from an original text (as to someone other than the original author, or to mark modifications in quotations. A bracketed ellipsis (...) is often used to indicate omitted material (as in I'd like to thank [several important people] for their presence...). Bracketed comments inserted into a quote indicate where the original has been modified for clarity (as in I appreciate it [the horse], but I must refuse, and the future of pianists [was defined] in its doubt), or cite can quote the original statement (as in I hate to do laundry with a modification [inserted in the middle of it] to: "hate[ed] to do laundry").	PILCROW Used as an indent for separate paragraphs or to designate a new paragraph in only long pieces of text, as in the following: The dog Agns to mark a new train of thought, before the completion of a usually discrete paragraph. Text sourced from internet sources.	QUESTION MARK The exclamation mark sometimes used in legal parenthetical thought, as a replacement for the word "no", as in "The defendant's attorney argued that the defendant was not guilty of the crime." The ex dash is used to indicate a range of values, such as those between dates, times and numbers and approximately replaces the word "to" (as in 1984–1993 or 2–5 May), or in the opening "from...to" (as in the New York–New Haven train, but not in a New York New Haven association) and to the minus sign, as in 10°C, but in text too.	BRACKET Are mainly used to insert explanatory material or to mark where a passage was omitted from an original text (as to someone other than the original author, or to mark modifications in quotations. A bracketed ellipsis (...) is often used to indicate omitted material (as in I'd like to thank [several important people] for their presence...). Bracketed comments inserted into a quote indicate where the original has been modified for clarity (as in I appreciate it [the horse], but I must refuse, and the future of pianists [was defined] in its doubt), or cite can quote the original statement (as in I hate to do laundry with a modification [inserted in the middle of it] to: "hate[ed] to do laundry").	PILCROW Used as an indent for separate paragraphs or to designate a new paragraph in only long pieces of text, as in the following: The dog Agns to mark a new train of thought, before the completion of a usually discrete paragraph. Text sourced from internet sources.

You've Got Punct Emily Waite (Student) Rachel Burger (Instructor) California College of the Arts San Francisco, CA, USA For this student poster project interpreting punctuation marks a baseline grid is used as the underlying typographic structure for defining size, alignment, and location criteria for continuous narrative text and vector-based images in relationship to typographic baselines.

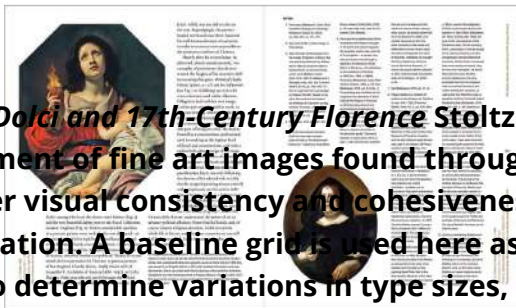

Carlo Dolci and 17th-Century Florence Stoltze Design Boston, MA, USA The size and placement of fine art images found throughout this exhibition catalog provide a further visual consistency and cohesiveness to the compositional layouts of this publication. A baseline grid is used here as an effective compositional substructure tool to determine variations in type sizes, as well as in page-to-page layouts.

Grid Systems

Hierarchical

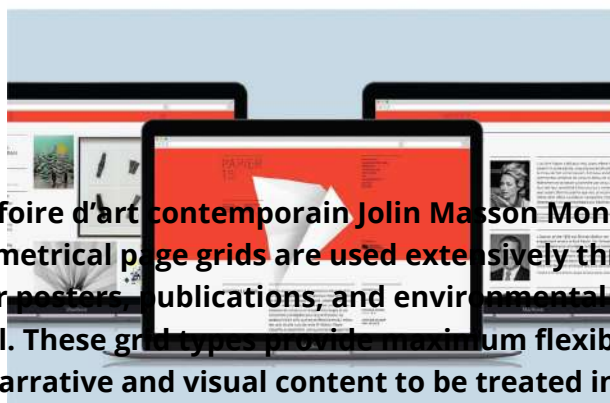

Papier 14, 15, and 16: foire d'art contemporain Jolin Masson Montréal, QC, CA
Hierarchical and symmetrical page grids are used extensively throughout this branding program, for posters, publications, and environmental graphics, reinforcing a modernist visual ideal. These grid types provide maximum flexibility and continuity, allowing for diverse narrative and visual content to be treated in a meaningful and accessible manner for the reader. The use of a Sans Serif Humanist typeface, Open Sans (Steve Matteson, 2010), for all primary typographic elements with a contemporary Old Style serif typeface, Mercury Text (Jonathan Hoefler, Tobias Frere-Jones, 1999), for all narrative text and caption information reinforces this ideal.

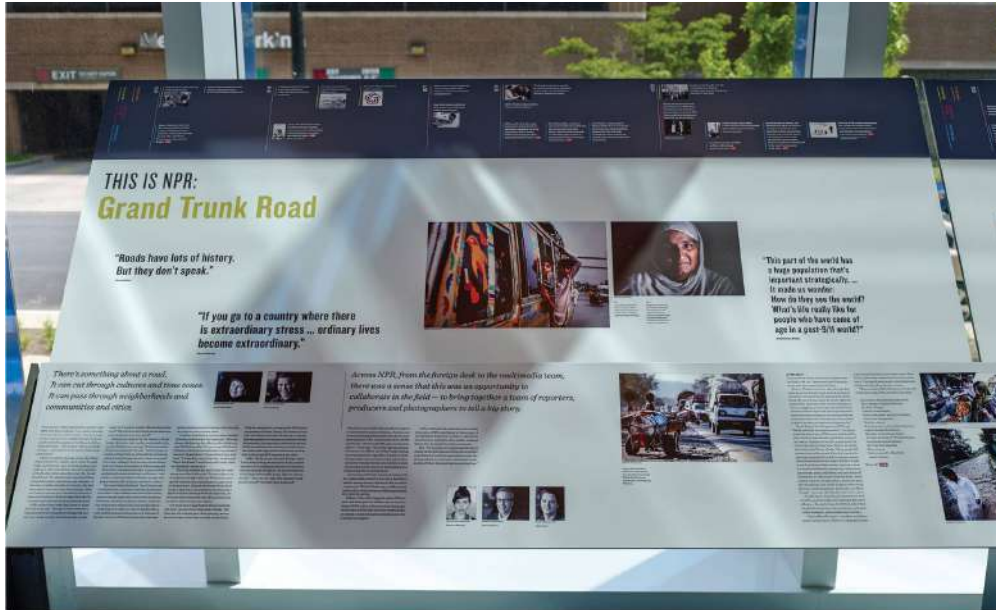

This is NPR Poulin + Morris Inc. New York, NY, USA A hierarchical grid system is used as the compositional framework for this 70-foot-long, permanent, interactive exhibition. It is organized in five sections, each dedicated to a story significant to NPR and its listeners, consisting of section titles, subheads, narrative text, pull quotes, captions, and photographic images. Its upper portion features NPR milestones integrated with a timeline highlighting public radio, world, and radio broadcast history.

Grid Systems
Compound



McGill University School of Architecture Final Reviews Atelier Pastille Rose Montréal, QC, CA The organization and symmetrical composition of this announcement poster is based on a thorough understanding and use of a simple compound grid. Large-scale typography is organized on a central columnar axis with smaller-scale text organized in two equal measure columns. Both sized columns are integrated into one organized, cohesive structure and framed with large-scale typography cropped at the poster's vertical edges.

<p>Scapegoat Architecture Land scape Political cal Economy Winter Spring 2015</p>		<p>Weather</p> <p>WEATHER SCAPEGOAT 8 Edited by Adam Bobbette, Seth Denzen</p> <p>3 Dear Climate Una Chaudhuri, Fritz Ertl, Oliver Kellhammer, Marina Zurkow</p> <p>4 Editorial Adam Bobbette, Seth Denzen</p> <p>10 Reading About Mexico City in Scapegoat Jorge Aguilar Mora</p> <p>14 A-bomb Tests Linked to Tornadoes? A Case for What Makes Weather Meredith Miller</p> <p>32 The Exorcism of Glaciers Andrew Toland</p> <p>48 Breathing in the City: Beijing and the Architecture of Air Jerry Zee</p> <p>60 Still Passing: Crisis, Youth and the Political Economy of Fog in Limbo Maria José A. de Abreu</p> <p>72 Breathless: Making Buildings and Weather on Sumatra Marcel Jäggi</p> <p>84 What is Dust? Paul Ginoux</p> <p>92 The Narrative of Human Extinction and the Logic of Ecosystem Management Phillip Stillman</p>	<p>106 Histoire d'une Montagne Elisée Reclus</p> <p>114 The Weather of Merapi Elisabeth Inandjak</p> <p>124 Camera in a Storm Peter Mettler</p> <p>132 Knowing the Weather: Heavens and Super-Computers in China Marijn Nieuwenhuis</p> <p>144 The Political Economy of Soil Piers Blaikie</p> <p>150 Video Proposal: 48 Abell Street Ice Rink Corwyn Lund</p> <p>162 Habis Bad! Galap Past! Terbitlah Terang Berlatu farid rakun</p> <p>170 Weather Balloon Diplomacy Jacob Kalmakoff Translation by Juhwa Pyun</p> <p>178 Undermining: A Wild Ride through Land Use, Politics and Art in the Changeling West Review by Sydney Hart</p> <p>186 Biographies</p>
--	--	--	---

Scapegoat Architecture Jack Henrie Fisher Chicago, IL, USA This representative page spread from an independent journal designed to create a context for research and development of design practices, historical investigation, and theoretical inquiry, demonstrates the effective use of two or more multiple-column compound grid systems.



Graphic Icons: Visionaries Who Shaped Modern Graphic Design Think Studio Maplewood, NJ, USA A compound grid is used throughout this publication to accommodate extensive narrative and visual content such as biographical information, pull-quotes, historical timelines, photography, and captions. This grid type provides an efficient methodology in which to create multiple layouts while maintaining visual consistency and cohesiveness.

Compositional Principles

Balance



Philadelphia Youth Orchestra Paone Design Associates Philadelphia, PA, USA These promotional posters are prime examples of effectively using the compositional principle of dynamic balance or asymmetry in a dramatic and memorable way. Each compositional layout is arranged in a deliberately unequal manner and appears random and dynamic, yet visually balanced.



Self Portrait Michelle Kwon (Student) Richard Poulin (Instructor) School of Visual Arts New York, NY, USA This poster uses the compositional principle of radial balance to organize and convey the levels of personal relationships that the designer has with family and friends. Each concentric circle is radiating from a central, common focal point; the inner circle is the most intimate set of relationships with the most outer circle identifying people that the designer has limited contact with.

Compositional Principles

Movement



MoMA Film Poster Series Jihyang Lim (Student) Scott Buschkuhl (Instructor) School of Visual Arts New York, NY, USA This poster series for a student project relies on the compositional principle of movement by creating a specific sequence of visual experiences based on typography, color, repetition, sequence, and alignment. While the films themselves are unrelated and random in theme and content, they are united as a set by this visual and compositional solution.

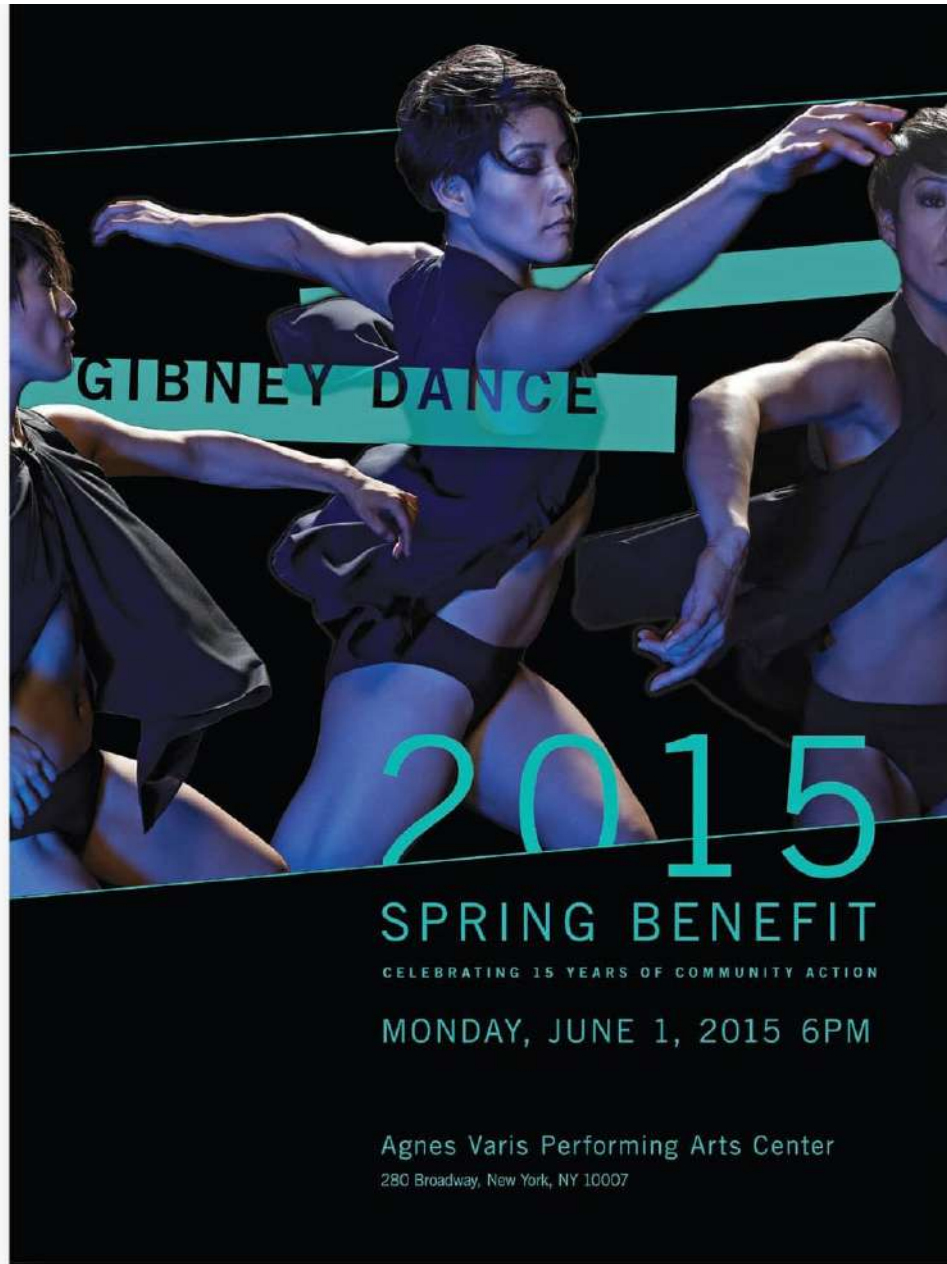

Gibney Dance Spring Benefit 2015 Poulin + Morris Inc. New York, NY, USA Dramatic four-color photography coupled with a vibrant color palette and intersecting typographic and linear forms are used to create striking, kinetic visuals that immediately communicate movement in this promotional poster.

SASAKI

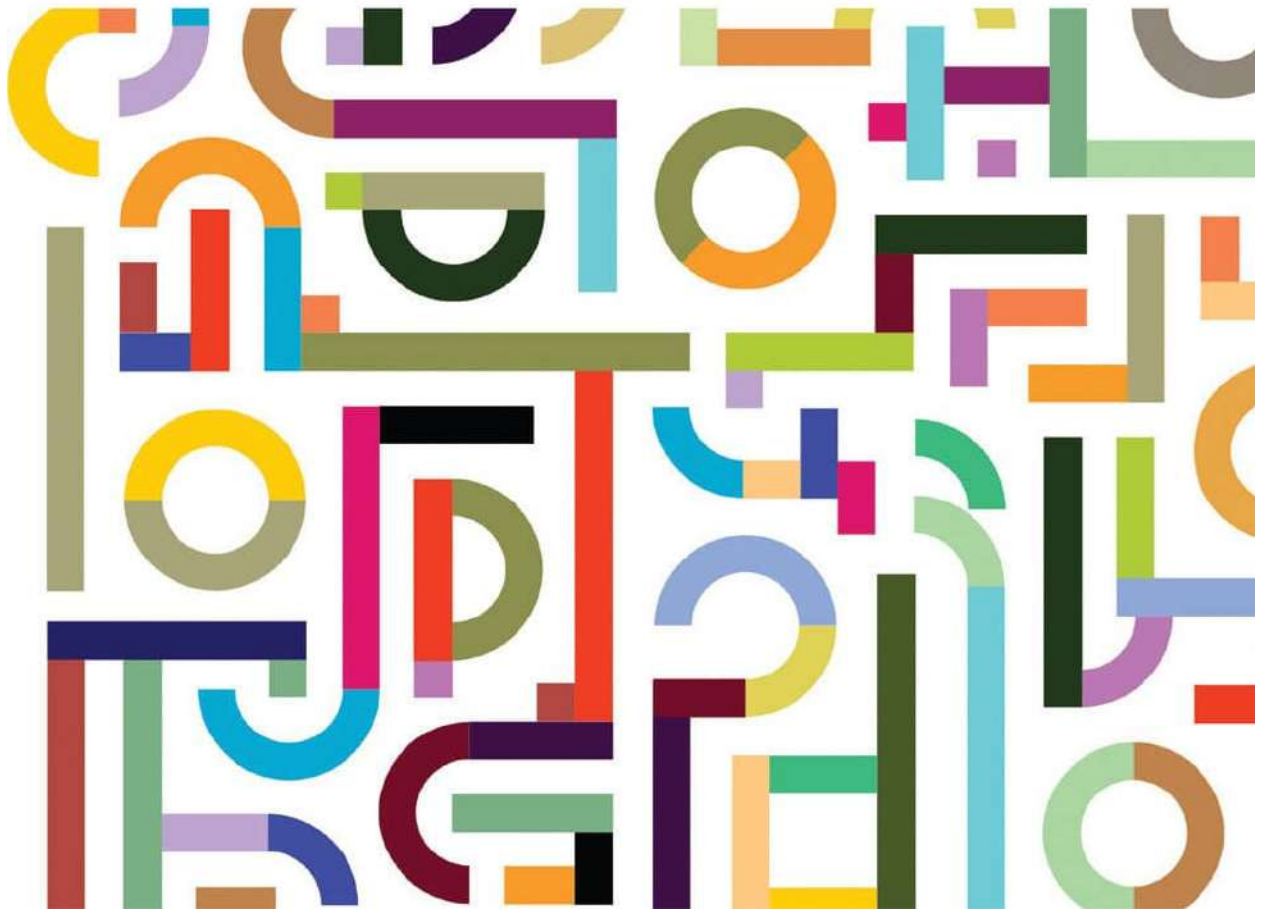

Sasaki Bruce Mau Design Toronto, ON, CA This branding and messaging system for a global planning and design practice is comprised of a wordmark generated from four core geometric shapes that shift in color to create vibrant logotype variations. These shapes are then used to form dynamic, kinetic typographic patterns, as well as visual language elements and a custom Sans Serif display typeface, used extensively throughout print and digital media components of the system.

Compositional Principles

Symmetry

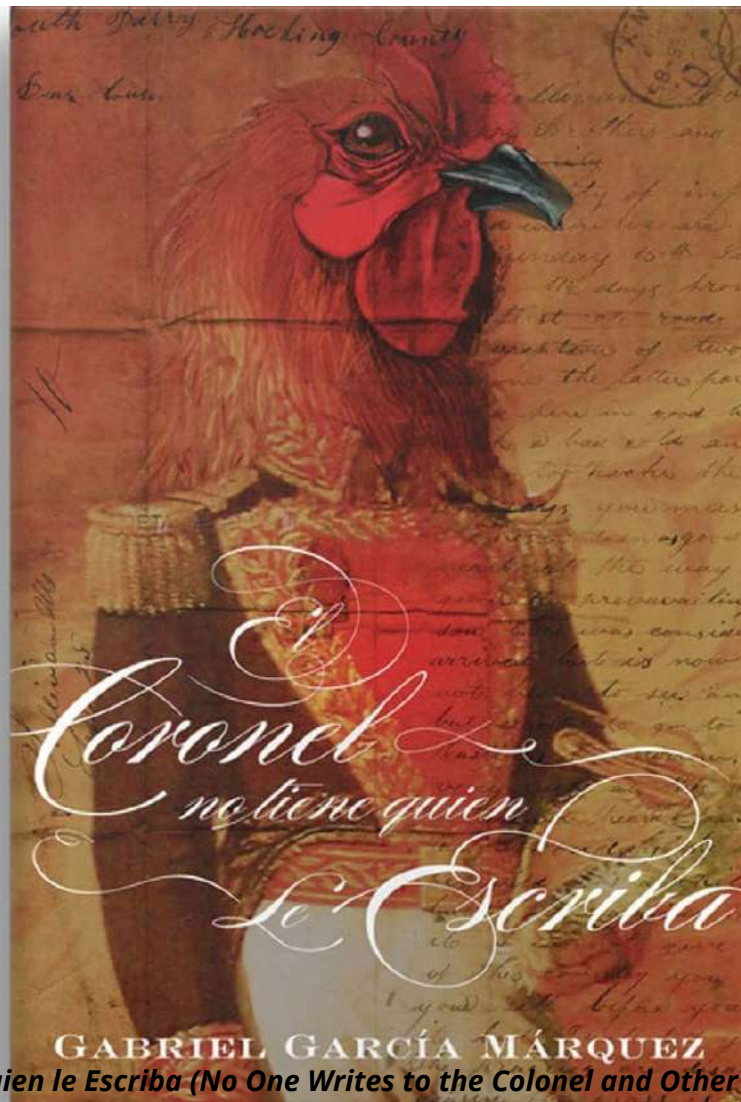

El Coronel no tiene quien le Escriba (No One Writes to the Colonel and Other Stories) Daniel Rodriquez (Student) Richard Poulin (Instructor) School of Visual Arts New York, NY, USA This book jacket for a set of short stories by Gabriel García Márquez conveys a refined visual character that captures the unique perspective and voice of the author. Its eye-catching imagery and fluid script typography is composed on a symmetrical axis that further strengthens the overall composition.



Details Blaine Pannell (Student) Adrian Pulfer (Instructor) Brigham Young University Provo, UT, USA Justified alignments of Sans Serif Grotesque typography set in varied columnar line lengths combined with symmetrical page compositions are used throughout this magazine redesign, conveying a varied and contemporary appearance from spread to spread and section to section. This alignment format also reinforces ease, legibility, and readability for the reader.

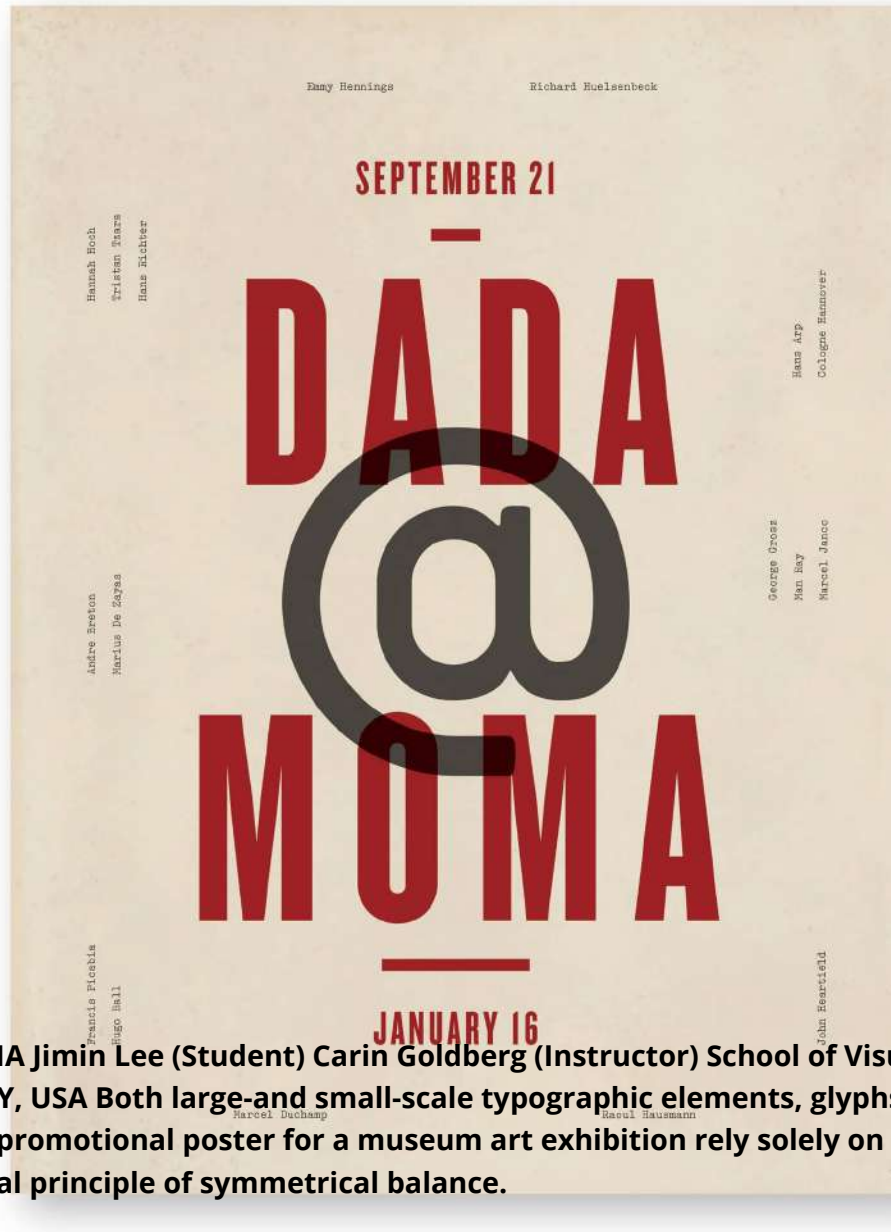

Dada @ MoMA Jimin Lee (Student) Carin Goldberg (Instructor) School of Visual Arts New York, NY, USA Both large-and small-scale typographic elements, glyphs, and linear rules of this promotional poster for a museum art exhibition rely solely on the compositional principle of symmetrical balance.

Compositional Principles

Asymmetry



Swissted Stereotype Design New York, NY, USA This poster series of vintage punk, hardcore, new wave, and indie rock show flyers has been reimagined in the Swiss Modernism genre and the International Typographic Style with all compositional layouts possessing a strong and apparent use of asymmetry. To reinforce this visual ideal, all posters are set in lowercase Berthold Akzidenz-Grotesk (1896).

Compositional Principles

Tension



Fluxus Jimin Lee (Student) Carin Goldberg (Instructor) School of Visual Arts New York, NY, USA This promotional poster for a museum art exhibition uses an unconventional combination of various letterforms, letter spacing, and orientations in an unorthodox composition to communicate visual tension, as well as the themes and brand of the exhibition.

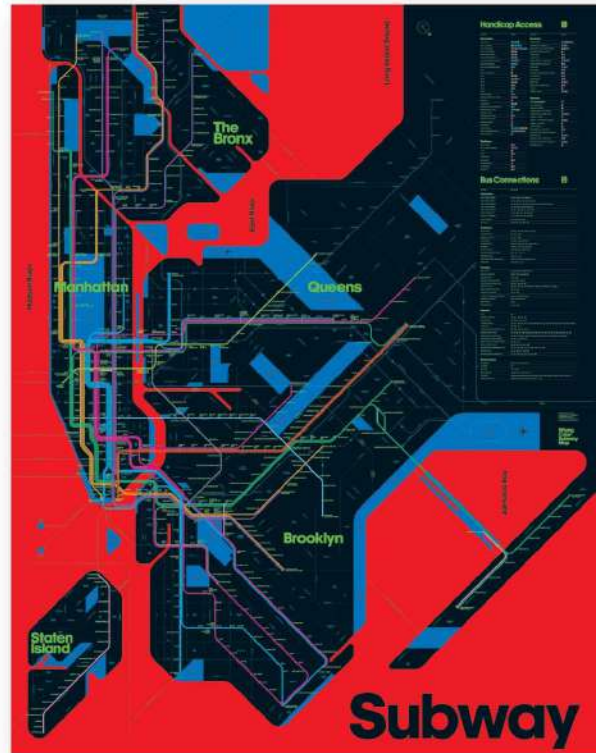

Wrong Color Subway Map Triboro Brooklyn, NY, USA This rethinking of the iconographic New York City subway map (Massimo Vignelli, 1972) in fluorescent color palettes of RGB and CMYK strips away the familiar color coding of the original version while still maintaining a level of hierarchy and functionality. The visual effect is intense and uncomfortable in some lighting conditions, while washed out and unreadable in others.

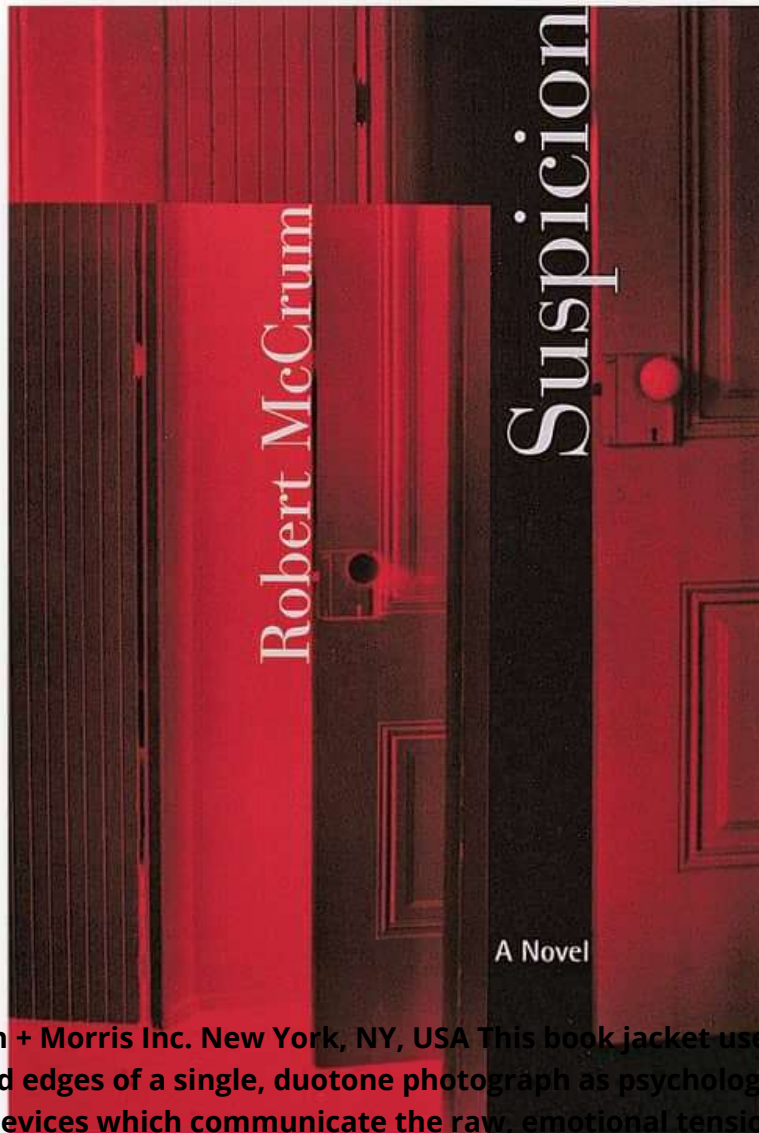

***Suspicion* Poulin + Morris Inc. New York, NY, USA This book jacket uses cropping, orientation, and edges of a single, duotone photograph as psychological, attention-getting visual devices which communicate the raw, emotional tension of the novel's main narrative. A dark value color palette appearing in alternating positive and negative forms, adds visual tension.**

Compositional Principles

Contrast



***On the Pulse of Morning* Sylvia Cisek (Student) Richard Poulin (Instructor)** School of Visual Arts New York, NY, USA Contrast in typography, photographic imagery, scale, and space are prominent characteristics of these page spreads from a poetry book that celebrates the narrative themes of Maya Angelou's inaugural poem. Dramatic photographic imagery is paired with impactful typographic forms that communicate the essence and symbolism in each line of the poem. Here, contrast is intuitively relied upon to create an emotional and meaningful experience for the reader.



Spy Museum Jihyang Lim (Student) Scott Buschkuhl (Instructor) School of Visual Arts New York, NY, USA These promotional posters are part of an overall branding program that was inspired by shredded documents, as well as high contrast that can only be achieved with a black and white color palette.

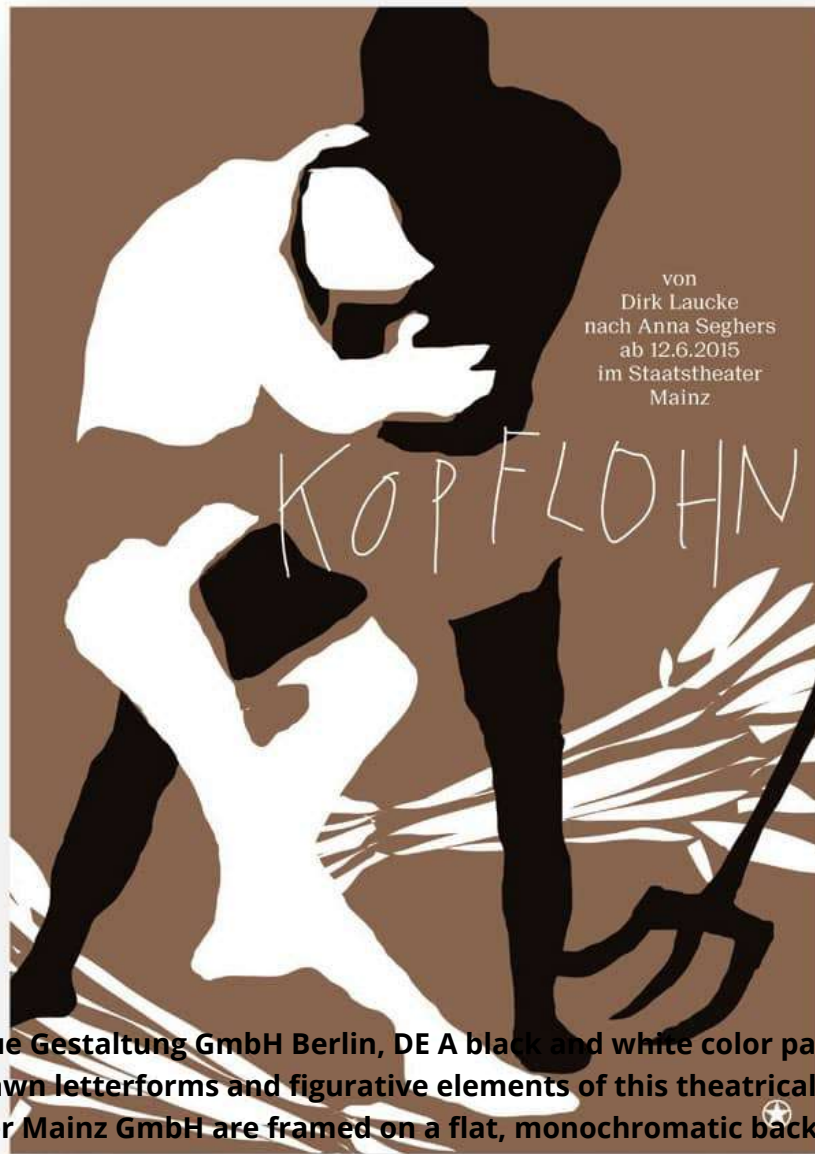

***Kopflohn* Neue Gestaltung GmbH Berlin, DE A black and white color palette used for the hand-drawn letterforms and figurative elements of this theatrical poster for the Staatstheater Mainz GmbH are framed on a flat, monochromatic background to create a powerful contrast for the foreground and background of this compositional layout.**

Compositional Principles

Figure-ground



Das Theater Erlangen Neue Gestaltung GmbH Berlin, DE This extensive promotional poster series for theatrical productions convey visual power and diversity when the compositional principle of figure-ground is used creatively and effectively. The visual diversity in each silhouette and profile of these dramatic illustrations reinforces the use of simple figure-ground relationships that create not only unique figures but also dynamic shapes that surround each figure.

Layout Characteristics
Pacing and Sequence



Layout Characteristics

Pattern and Form



School of Visual Arts' 2017 Senior Library Hinterland New York, NY, USA The book jacket and page spreads of this publication show how disparate patterns and forms can be used to create a cohesive, singular statement. In this context, there is no true beginning, middle, or end to the book experience. It is non-linear, just like a designer's education, thinking, career, and professional life after graduation.



Mostafa Mastoor Short Stories Studio Abbasi Tehran, IR This series of book jackets reflect a sensitive balance of pattern and form by using a combination of Arabic calligraphic letterforms, extreme scale change, opposing compositional axes, pure linear graphic elements, and color to create visual impact for the reader.

Layout Characteristics
Rhythm and Flow

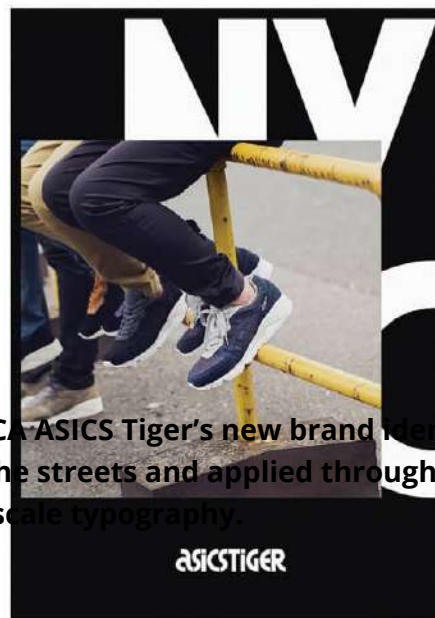

ASICS Tiger Bruce Mau Design Toronto, ON, CA ASICS Tiger's new brand identity system is inspired by overlapping wild postings on the streets and applied through the use of bold brand photography layered with large-scale typography.



Martin Luther King Jr. Alexander Cantanese (Student) Jillian Coorey (Instructor) Kent State University Kent, OH, USA A dramatic, hand-drawn appearance to these script-like letterforms, combined with formal typography appearing throughout this book on Martin Luther King Jr., convey a visual rhythm and sound-like experience that is evocative of the power and import of his words.



JFK Terminal 4 Base Design New York, NY, USA This brand identity's logotype and custom Sans Serif typeface convey a friendly visual rhythm and series of varied forms when paired with vibrant colors and a bright white background. From wall murals and digital directories to retail corridor walls and gate graphics, program elements are equally effective in large-scale environmental graphics as well as small-scale print and digital applications.

Layout Characteristics

Space



Brewster Murray Frost* Collective Sydney, NSW, AUS This brand identity is based on the use of a single letterform that when oriented vertically communicates the duality of the BM mark. This simple, yet innovative, solution reinforces an intelligence and resourcefulness with the use of a seminal Sans Serif Neo-Grotesque typeface—Helvetica (Max Miedinger, 1956). Additionally, when this singular visual element is layered with smaller-scale typographic messages, they collectively create dynamic compositional spaces that are another prominent layout characteristic of this program.

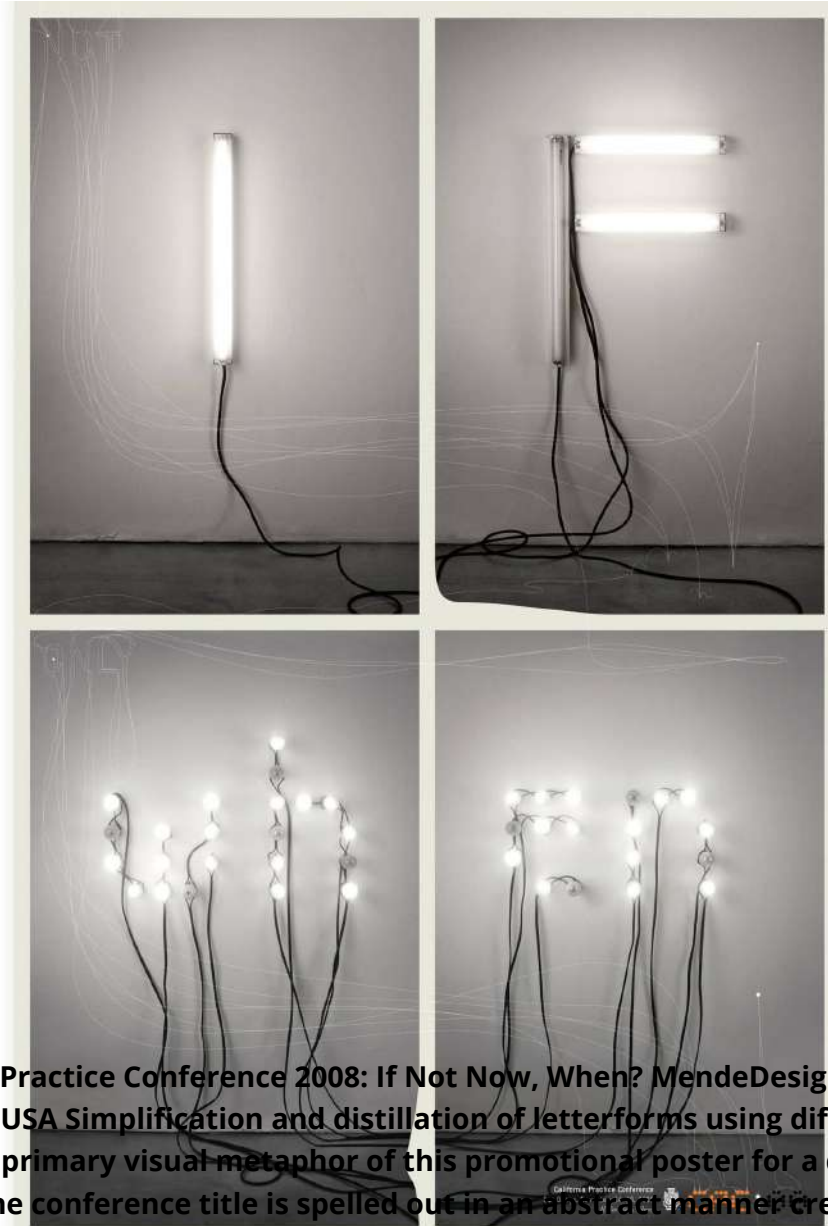

AIA California Practice Conference 2008: If Not Now, When? MendeDesign San Francisco, CA, USA Simplification and distillation of letterforms using different light fixtures is the primary visual metaphor of this promotional poster for a design conference. The conference title is spelled out in an abstract manner creating a psychological compositional space, as well as further conveying the theme of the conference.

Layout Characteristics

Alignment

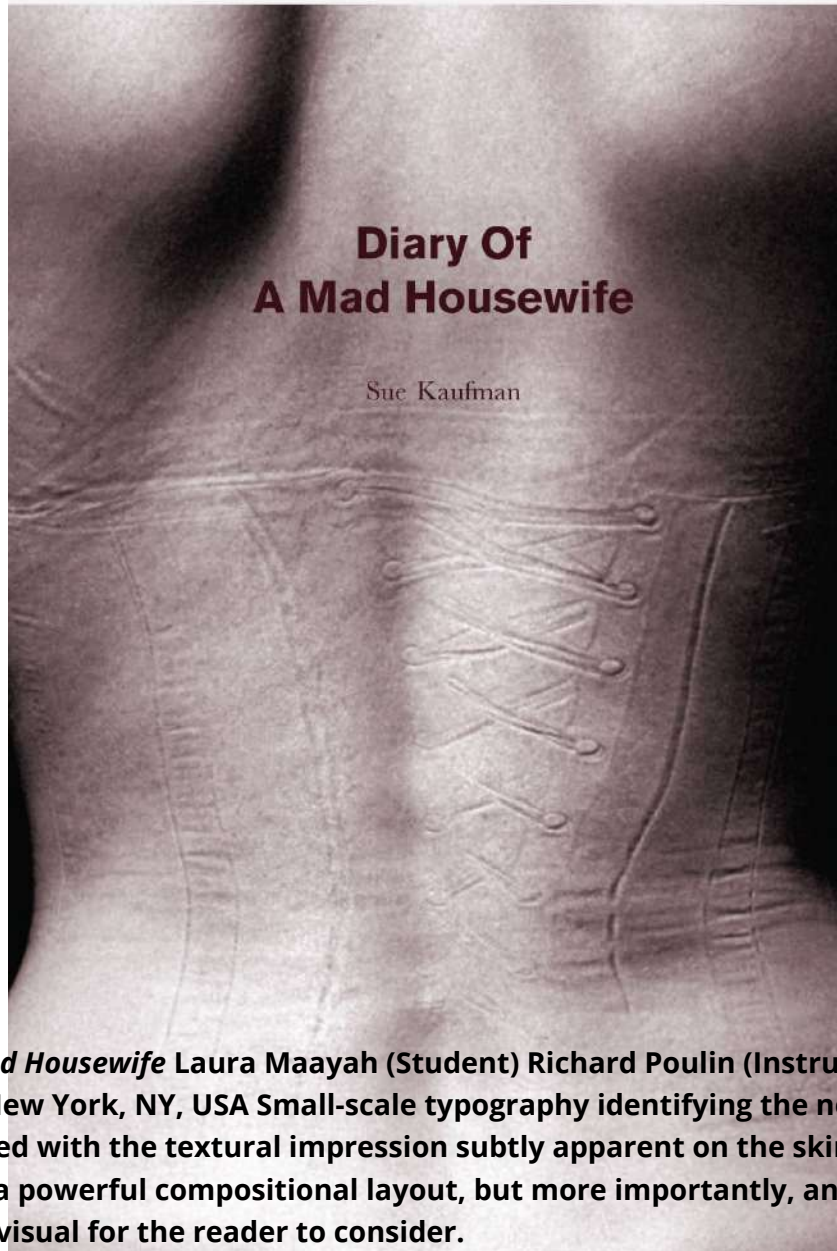

Diary of a Mad Housewife Laura Maayah (Student) Richard Poulin (Instructor) School of Visual Arts New York, NY, USA Small-scale typography identifying the novel's title and author aligned with the textural impression subtly apparent on the skin of a woman's back create a powerful compositional layout, but more importantly, an emotional and provocative visual for the reader to consider.

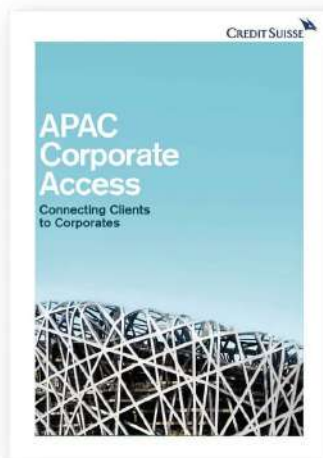
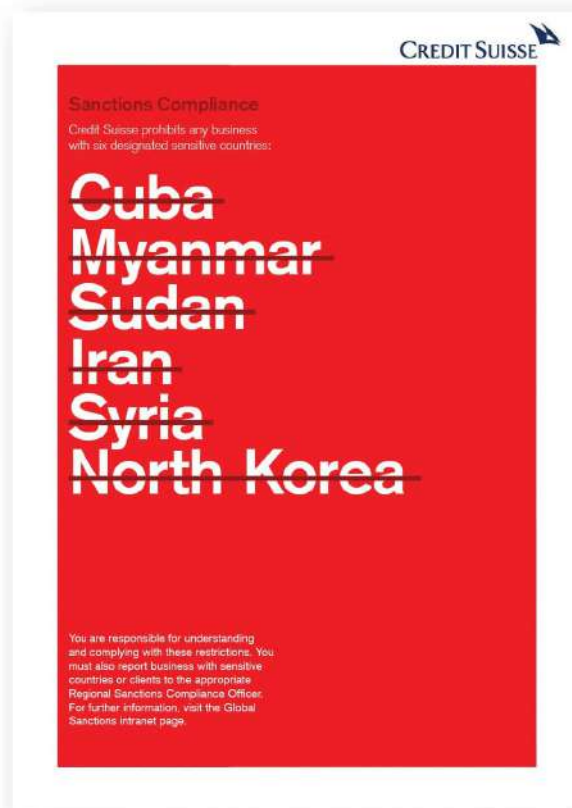

Credit Suisse Carbone Smolan Agency New York, NY, USA This extensive branding system and global recruiting campaign for a financial services and wealth management firm, ranging from poster templates to standardized iconography and data visualization design standards, relies upon a vivid color palette, rigorous page grids, Sans Serif Neo-Grotesque typography (Akzidenz Grotesk, 1896), and asymmetrical compositional layouts with a strong flush left alignment. All of these visual characteristics are appropriate, relevant, and reminiscent of the Swiss International Typographic Style and used consistently throughout the campaign's print and digital applications.

Layout Characteristics

Emphasis, Hierarchy, and Scale

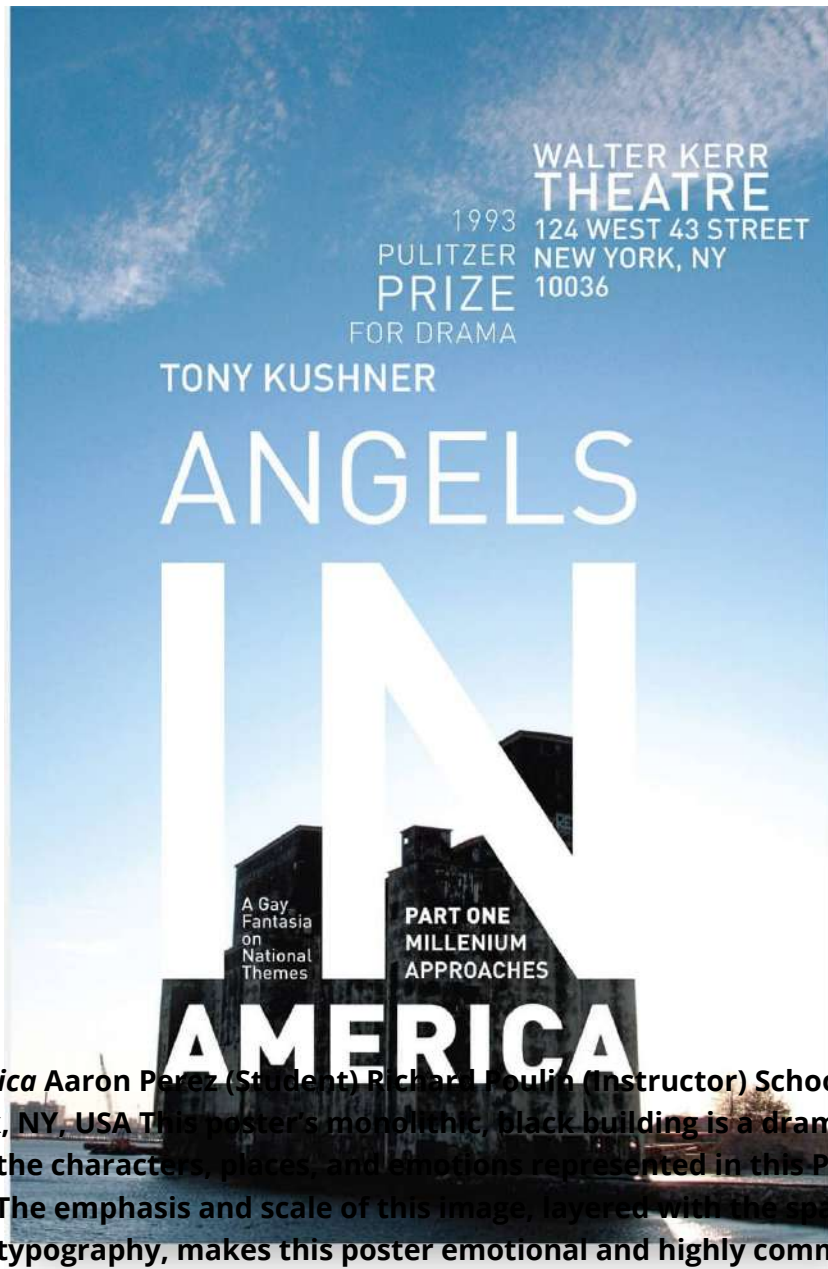

Angels in America Aaron Perez (Student) Richard Moulin (Instructor) School of Visual Arts New York, NY, USA This poster's monolithic, black building is a dramatic visual metaphor for the characters, places, and emotions represented in this Pulitzer Prize-winning play. The emphasis and scale of this image, layered with the spatial hierarchy of supporting typography, makes this poster emotional and highly communicative.

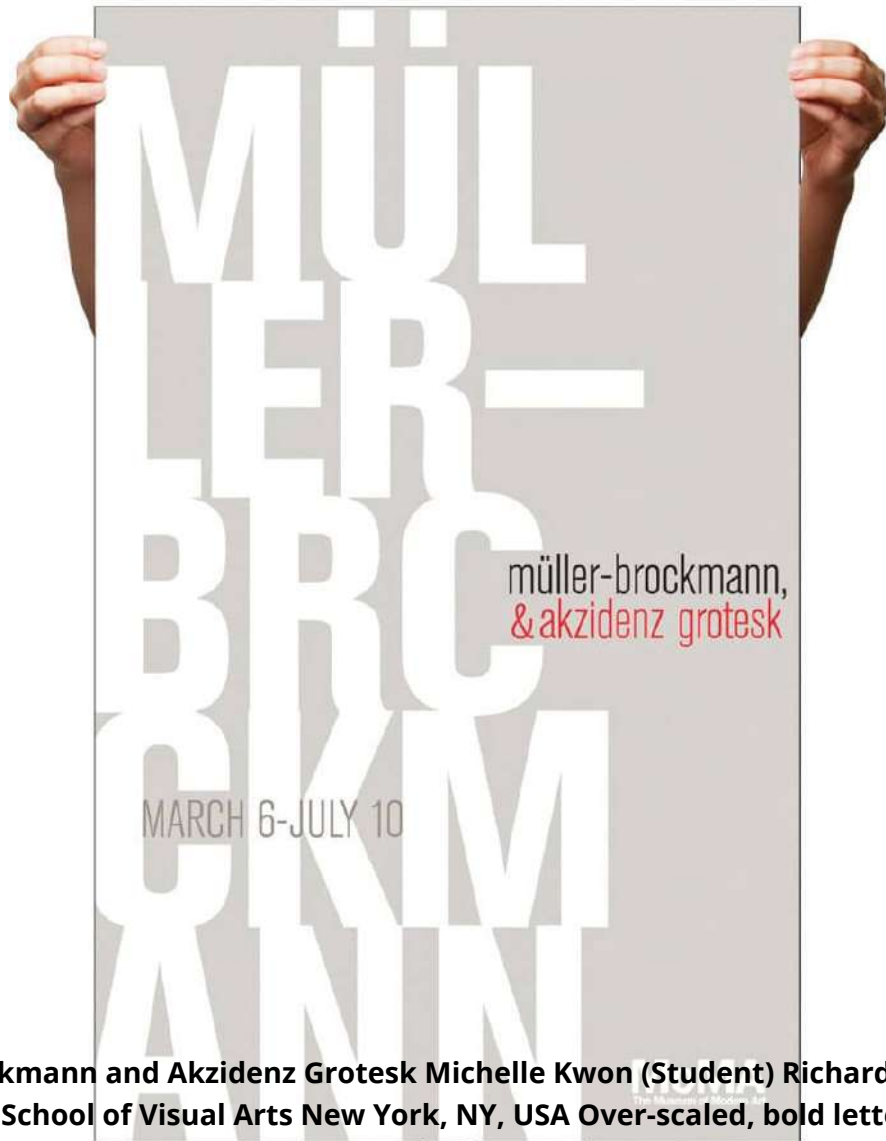

Müller-Brockmann and Akzidenz Grotesk Michelle Kwon (Student) Richard Poulin (Instructor) School of Visual Arts New York, NY, USA Over-scaled, bold letterforms are the primary compositional element of this poster celebrating the design philosophy of Josef Müller-Brockmann and his reliance on the modernist Sans Serif typeface Akzidenz Grotesk (1896) in all of his work.

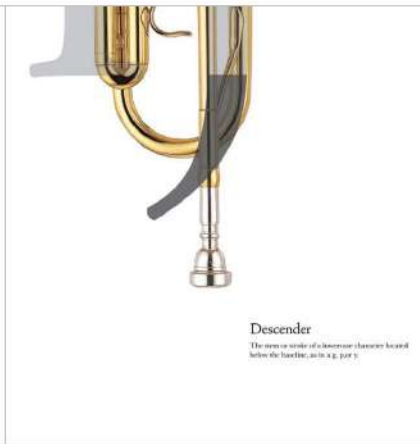

***Listen to the Type* Kiho Lee (Student) Richard Poulin (Instructor) School of Visual Arts New York, NY, USA** This book is a visual celebration of typographic anatomy, classifications, and definitions paralleled with the structure and design of musical instruments. The visual characteristics of emphasis, hierarchy, and scale are used throughout each of these page compositions to show the similarities between the two unrelated forms in a clear and concise manner.

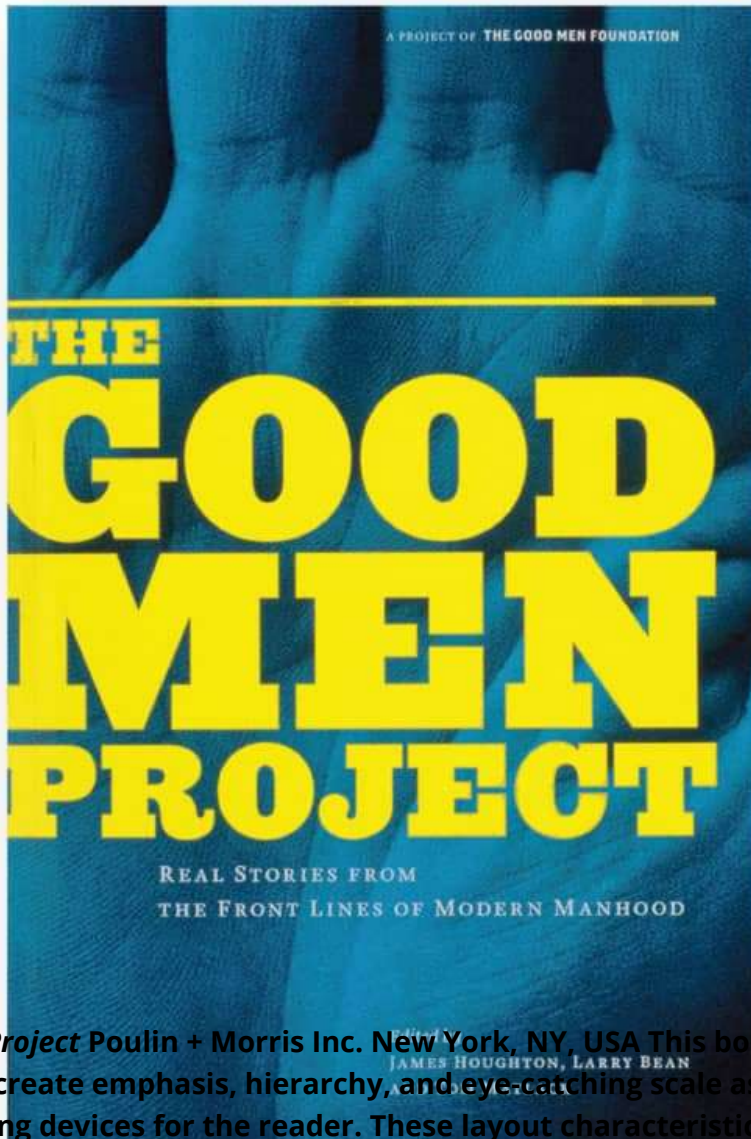

The Good Men Project Poulin + Morris Inc. New York, NY, USA This book cover uses asymmetry to create emphasis, hierarchy, and eye-catching scale as powerful, attention-getting devices for the reader. These layout characteristics are further strengthened with the effective use of an iconic photographic image, bold typography, vibrant color, and distinctive proportions.

Test your Knowledge Answers

Section 1: Layout Fundamentals

1. The primary distinctions of an absolute measurement system and a relative measurement system are a fixed value of units versus a relative value based on a specific point size of a typeface.
2. The standard fixed values of units of the American–British point system are point and pica.
3. The standard fixed values of units of the metric system are millimeters.
4. The two (2) rational values of relative type measurement in typography are an em and en.
5. Three (3) proportional systems that a graphic designer can use to create varied spatial relationships in a compositional layout are the Golden Section, the Fibonacci sequence, and Dynamic Rectangles.
6. One of the most universal images representing the visual theory of a proportional system, created by Leonardo da Vinci, is called The Vitruvian Man.
7. The numerical ratio of the golden section is 1.61803.
8. To construct a Van de Graaf canon, see [here](#).
9. The Fibonacci sequence is based on the numerical sequence of 0, 1, 1, 2, 3, 5, 8, 13...
10. To construct a dynamic rectangle and its aspect ratio, see [here](#).
11. The name of the proportional system developed by noted modernist architect Le Corbusier is called Le Modulor.
12. The height-to-width ratio of ISO standard paper sizes is 1:1:4142.
13. The ISO standard paper size system is based on the metric absolute measurement system.
14. To construct a Villard diagram, see [here](#).

Section 2: Grid Systems

1. The simplest type of grid system, derived from written manuscripts of the early fourteenth and fifteenth centuries, is called a manuscript grid.
2. A symmetrical grid is composed of a primary rectangular text area, which is used to display extensive continuous text, and its left-and right-page text blocks mirror one another with a wider inner margin.
3. The most effective way of adding visual interest and variation to a compositional layout that uses a manuscript grid is with the adjustment of the proportions of its margins.
4. The primary visual characteristics of a symmetrical grid are that the left-and right-hand pages are mirror images of one another and the inner margins of both pages are the same width as the outer margins.

5. Verso, from the Latin term *verso folio*, is the term used to identify the left-hand page of a compositional layout or double-page spread.
6. Recto, from the Latin term *recto folio*, is the term used to identify the right-hand page of a compositional layout or double-page spread.
7. The primary visual characteristic of a single-column symmetrical grid is a singular block or single-column symmetrical composition of continuous narrative text with two equal inner and outer vertical margins.
8. The primary advantages of utilizing a double-or multiple-column symmetrical grid for compositional layouts is that it can be used for extensive narrative text or different types of narrative text information that need to be organized in separate and distinct visual fields or columns.
9. An optimum measure or character count for any given column width and line length for optimum readability and legibility is sixty (60) to seventy-two (72) characters (including word spaces) per text line.
10. An optimum measure or character count for a multiple column width and line length for optimum readability and legibility is forty (40) to fifty (50) characters (including word spaces) per text line.
11. The primary visual characteristic of a modular grid is multiple horizontal and vertical columns that form distinct fields or spatial zones (usually squares), which can be combined vertically and horizontally in a compositional layout for organizing and composing narrative and image content in a consistent manner.
12. One method for determining the size and proportion of a module in a modular grid is to look at the width and depth of an average paragraph of continuous narrative text at in a given type style and type size or at the proportion or orientation (vertical or horizontal) of images used in a compositional layout.
13. The modular grid had its genesis in the Bauhaus and the International Typographic Style.
14. The primary visual characteristic of an asymmetrical grid is that the recto and verso pages are the same and typically introduce a bias toward one page or the other (usually the left), imparting an asymmetrical, or imbalanced, visual appearance to a compositional layout.
15. The primary visual characteristics of a baseline grid are a series of equally spaced, parallel baselines for the placement of continuous narrative text, larger-scale type, and related visual elements.
16. The two (2) primary advantages of using a baseline grid in a compositional layout are: it provides definitive size and location criteria for continuous narrative text, since it gives exact locations for each baseline of text; and it allows continuous narrative text in different columns or on different pages to align, irrespective of type size.
17. The method for defining the size and placement of images in a baseline grid is by their placement and position to an x-height (the height of the lowercase letters such as x) and baseline of the nearest corresponding line in the text block, and can extend across text columns to maintain consistency and cohesiveness in a composition layout.
18. The primary visual characteristic of a hierarchical grid is a system of alignments and zones for text and images that varies from page to page, with its column width and proportion directly derived from diverse visual and narrative content.

19. The primary visual characteristic of a Marber grid is three horizontal bands where the cover image occupies the lower two thirds of the layout, with typographic information and colophon located in the upper third of the grid.
20. The primary visual characteristics of a compound grid are created by the integration of two or more multiple-column grid systems into one organized, cohesive structure.

Section 3: Anatomy of a Grid

1. The primary distinctions of a margin and gutter in a grid system are that margins are the borders or negative spaces located between the edges of a compositional layout defining a live area, whereas a gutter is an inactive space needed either as an internal edge for binding or to separate columns of running text.
2. The primary distinctions of a column, module, and spatial zone in a grid system are that a column is a vertical alignment of type that creates horizontal divisions between the live area of a compositional layout's margins; a module is an individual unit of space within a page grid separated by regular intervals that, when repeated across the page, create columns and rows of varying sizes; and a spatial zone is a group of modules that form distinct fields within a page grid for displaying similar information in a consistent manner.
3. The difference between a fore-edge and back-edge in a grid system is that a fore-edge is the outside edge or margin of a book page; or the edge or margin opposite the spine of a book or publication; and a back-edge is a vertical margin located at the back edge of the page that is closest to the spine or center fold of the page.
4. Three primary typographic characteristics that need to be considered when establishing a column width and measure are type size, line length, and leading.
5. A recommended character count per text line for any given line length or column width for optimum readability is sixty (60) to seventy-two (72) characters (including word spaces) per text line.
6. In a modular grid system, a series of horizontal flowlines that divide vertical columns into rows are used to create modules.
7. The term used to describe a group of modules in a grid system that form distinct fields in a compositional layout is spatial zones.
8. Another name for the horizontal alignment element in a grid system that organizes visual and narrative content into defined areas in a compositional layout is flowline or hangline.
9. A marker is a placement indicator in a grid system for supporting page information such as running headers or footers, folios or page numbers, or any other repeating element that occupies a consistent location on a page layout or spread.
10. Three (3) locations on a page grid where gutters can be used and/or located are 1) as an internal edge for binding; 2) to separate columns of running text; and 3) as a central margin of a grid where two pages meet at the spine.

Section 4: Compositional Principles

1. Three (3) distinct types of visual balance are formal balance or symmetry, dynamic balance or

1. Three (3) distinct types of visual balance are formal balance or symmetry, dynamic balance or asymmetry, and radial balance.
2. The primary visual characteristics of formal balance or symmetry are when visual elements are arranged equally on both sides of a compositional layout and appear stable or static, and the two sides of the composition are identical and reflect one another.
3. The primary visual characteristics of dynamic balance or asymmetry are when visual elements are arranged in a deliberately unequal manner in a compositional layout and appear random and dynamic, and the composition lacks balance and appears visually off-kilter.
4. The primary visual characteristic of radial balance is that the visual elements in a compositional layout radiate out from a central, common point in a circular direction, and that their visual weight is equal.
5. Three (3) design elements and principles that a graphic designer can use to create various degrees of visual balance in a compositional layout are color, value, and texture.
6. Two (2) visual techniques that a graphic designer can use to create the visual characteristics of movement in a compositional layout are repetition and rhythm.
7. Two (2) types of reflective symmetry are horizontal and vertical symmetry. Horizontal symmetry is created with an imaginary horizon or a left-to-right line functioning as the divider of a compositional layout, with the top and bottom sections mirroring one another.
8. Vertical symmetry is created with an imaginary vertical or a top-to-bottom line functioning as the divider of a compositional layout, with the left and right sections mirroring one another. Rotative symmetry is created in a compositional layout by rotating equivalent elements in an outward direction from a common center point, while drawing attention inward.
9. Translative symmetry is created by locating equivalent elements in different areas of a compositional layout.

Section 5: Layout Characteristics

1. Two (2) distinct methods for achieving visual pacing and sequencing in multiple compositional layouts are the use of over-scaled type and images and a reliance on full-bleeds of images and background colors.
2. Three (3) distinct types of patterns that can be used in compositional layouts are synthetic, mechanical, and man-made.
3. The primary visual characteristics of real and illusory forms in a compositional layout are as follows: real, three-dimensional forms such as objects, sculpture, and architecture contain actual volume or physical weight; illusory, two-dimensional forms are perceptual and are illusions of three-dimensional shapes in two-dimensional spaces that occur on a printed or virtual page.
4. The visual characteristic of an isometric projection is that when all axes of a form are simultaneously rotated away from the picture plane and kept at the same angle of projection (30 degrees from the picture plane), all lines are equally foreshortened, and the angles between lines, are 120 degrees.
5. The visual characteristic of an axonometric projection is that when a parallel projection of a form is viewed from a skewed direction, more than one of its sides is revealed in the same picture plane.

6. The primary visual characteristics of regular, flowing, and progressive visual rhythms in a compositional layout are (regular) when the spatial intervals located between compositional elements, and often the elements themselves, are similar in size, length, or visual character; (flowing) when it conveys a sense of movement in a layout between its compositional elements or from one page to another, and is often perceived as more organic and natural in its visual character; and (progressive) when it is created with a sequence of compositional elements through a defined progression of steps.
7. The primary visual distinctions of actual, pictorial, psychological, and physical spaces in a compositional layout are: (actual) when it is the area that a visual composition physically occupies; (pictorial) when it is the manipulation of a flat surface to create a perception of depth, movement, or direction, and it relies on optical illusion to deceive the mind and eye of a reader; (psychological) when it is a visual composition that influences the mind and eye of a reader; and (physical) when it is the three-dimensional world.
8. The visual characteristics of atmospheric perspective is the modification of the appearance of the composition's elements—the lightening of value, lowering of contrast, softening of edges, minimizing of detail, or muting of color.
9. The visual characteristics of one-point or linear perspective is the convergence of parallel lines toward a single vanishing point located on a horizon or eye-level line. Perspective lines that are located above an eye-level line are drawn diagonally down toward the vanishing point; lines that are located below an eye-level line are drawn diagonally up toward it. Vertical lines indicate height and horizontal lines indicate width; in both orientations, the lines remain parallel.
10. The visual characteristics of two-point or planar perspective are that a three-dimensional element is perceived from a vantage point that always reveals a corner or another side of the element, and that two visible sides of an element stretch away toward two vanishing points located in the distance on an eye-level line. Vertical lines remain parallel to one another.
11. The four (4) basic compositional alignment formats used in compositional layout are flush left, flush right, justified, and centered.
12. The primary visual characteristics, and the advantages and disadvantages, of each alignment format are as follows: a flush left text alignment creates word spacing that is uniform and even; the same occurs with flush right and centered alignments; a flush left text alignment requires hyphenation of words to prevent longer words, creating an excessively ragged right-hand margin; with a justified text alignment, word spacing varies because the width of the column is fixed and the words on every line need to align with both vertical edges, creating “rivers,”—arbitrary negative spaces that occur and visually connect from line to line within any columnar text setting.
13. The primary methods for achieving emphasis in a compositional layout are locating visual elements in a compositional layout in locations where the eye is naturally drawn, or by using contrast, repetition, or movement to draw visual attention to it. Variation in size, white space, color, and juxtaposition also reinforce emphasis of any visual element in a compositional layout.
14. The primary visual characteristics of objective scale and subjective scale are as follows: objective scale is the actual dimensions of a physical element, object, or space, or a literal relationship between that actual element, object, or space and its graphic representation; and subjective scale refers to a person's impression of an actual element, object, or space.

Bibliography

- Ambrose, Paul and Harris, Paul. *Basic Design: Layout*. Lausanne: AVA Publishing SA, 2005.
- Ambrose, Paul and Harris, Paul. *The Fundamentals of Graphic Design*. Lausanne: AVA Publishing SA, 2009.
- Ambrose, Paul and Harris, Paul. *The Layout Book*. London: Bloomsbury, 2015.
- Birdsall, Derek. *Notes on Book Design*. New Haven: Yale University Press, 2004.
- Dabner, David; Stewart, Sandra and Zempol, Eric. *Graphic Design School: The Principles and Practice of Graphic Design*. Hoboken: John Wiley & Sons, 2014.
- Elam, Kimberly. *Geometry of Design: Studies in Proportion and Composition*. New York: Princeton Architectural Press, 2001.
- Elam, Kimberly. *Grid Systems: Principles of Organizing Type*. New York: Princeton Architectural Press, 2007.
- Elam, Kimberly. *Typographic Systems*. New York: Princeton Architectural Press, 2005.
- Evans, Poppy and Thomas, Mark A. *Exploring the Elements of Design*. New York: Thomas Delmar, 2008.
- Graver, Amy and Jura, Ben. *Grids and Page Layouts: An Essential Guide for Understanding and Applying Page Design Principles*. Beverly: Rockport Publishers, 2012.
- Hemenway, Priya. *Divine Proportion*. New York: Sterling Publishing Co., 2005.
- Hollis, Richard. *Swiss Graphic Design: The Origins and Growth of an International Style, 1920–1965*. New Haven: Yale University Press, 2006.
- Krause, Jim. *Design Basics Index: A Graphic Designer's Guide to Designing Effective Compositions, Selecting Dynamic Components and Developing Creative Concepts*. Cincinnati: How Design Books, 2004.
- Leborg, Christian. *Visual Grammar*. New York: Princeton Architectural Press, 2004.
- Lidwell, William; Holden, Kristina; Butler, Jill. *Universal Principles of Design*. Beverly: Rockport Publishers, 2003.
- Lupton, Ellen and Phillips, C. Jennifer. *Graphic Design: The New Basics*. New York: Princeton Architectural Press, 2008.
- Lupton, Ellen. *Thinking with Type*. New York: Princeton Architectural Press, 2004.
- Meggs, Philip B. *A History of Graphic Design*. Hoboken: John Wiley & Sons, 2005.
- Meggs, Philip B. *Type & Image: The Language of Graphic Design*. New York: Van Nostrand Reinhold, 1989.

Müller-Brockmann, Josef. *Grid Systems in Graphic Design*. Niederteufen: Verlag Arthur Niggli, 1981.

Poulin, Richard. *The Language of Graphic Design: An Illustrated Handbook for Understanding Fundamental Design Principles*. Beverly: Rockport Publishers, 2011.

Samara, Timothy. *Design Elements: A Graphic Style Manual: Understanding the Rules and Knowing When to Break Them*. Beverly: Rockport Publishers, 2007.

Samara, Timothy. *Design Evolution: Theory into Practice: A Handbook of Basic Design Principles Applied in Contemporary Design*. Beverly: Rockport Publishers, 2008.

Samara, Timothy. *Making and Breaking the Grid: A Graphic Design Layout Workshop*. Beverly: Rockport Publishers, 2002.

Tondeau, Beth. *Layout Essential: 100 Design Principles for Using Grids*. Beverly: Rockport Publishers, 2009.

White, Alex. *The Elements of Graphic Design: Space, Unity, Page Architecture, and Type*. New York: Allworth Press, 2002.

Index

A

A series paper sizes [37](#), [39](#), [59](#)

absolute measurement systems [14](#), [58](#)

actual space [58](#), [162](#)

Aeneid (Virgil) [25](#)

Albers, Anni [155](#)

Albers, Josef [146](#)

Alberti, Leon Battista [37](#)

Alcher, Otl [146](#)

alignment [58](#), [167](#), [170](#), [218](#)

alleys [56](#), [57](#)

Allianz [126](#), [146](#)

ambiguous figure-grounds [58](#)

American-British Point System [14](#), [59](#)

Apple iPod [22](#)

Arp, Hans [126](#)

asymmetry

 composition [59](#), [123](#), [131](#), [202](#)

 grid systems [59](#), [78](#), [98](#), [188](#)

L'Atlantique (Cassandre) [172](#), [173](#)

atmospheric perspective [59](#), [165](#), [166](#)

axonometric projection [59](#), [159](#)

B

B series paper sizes [37](#), [39](#), [60](#)

back-edge margins [50](#), [59](#)

back matter [59](#)

balance [59](#), [120](#), [196](#)

baseline grid systems [59](#), [102](#), [103](#), [190](#)

baselines [59](#)

Bauhaus [92](#), [130](#), [133](#), [140](#)

Bayer, Herbert [133](#)

Beall, Lester [163](#)

Berlage, H. P. [135](#)

Bernhard, Lucien [156](#)

bilateral symmetry *see* symmetrical compositions

Bill, Max [74](#), [126](#), [146](#)

Birdsall, Derek [111](#)

bleed [59](#)

blind folios [59](#)

block grid systems *see* manuscript grid systems

book sizes [41](#)

bottom margins *see* foot margins
Boy and Girl on a Fence (Beall) 163

C

C series paper sizes 37, 39, 60
Canadian paper sizes 39
capital letterforms 171
captions 60
case 171
Casey, Jacqueline 121
Cassandre, A. M. (Adolphe Mouron) 172
centered alignment 58, 169
centimeters 60
characters
 adjusting proportions 17
 count per line 52, 89
 single-column grids 83
Chartres Cathedral, France 22
chiaroscuro 60, 141
closure 60
collage 60
color 60, 123, 141, 171
column gutters *see* gutters
columns 52, 53, 60
 width 52, 65, 89, 90
compound grid systems 60, 112, 113, 194
consistency 60
Constructivism 135
contrast 60, 139, 142, 153, 171, 206
Cooper, Muriel 121
crown (book size) 42, 60
Cunningham, Merce 136

D

Da Vinci, Leonardo 17, 18
Vitruvian Man 6, 18
Day, Lucienne 155
De divina proportione (Pacioli) 18
demy book size 42, 60
Didot, François-Ambroise 15
didots 60
direction 61, 124
Divina proporción tipográfica (Rosarivo) 24
divine proportion *see* golden section
double squares *see* dynamic rectangles
drop lines *see* hang lines

Dürer, Albrecht 18
Dwiggins, William Addison 182
dynamic rectangles 25, 26, 61

E

Eames, Charles: LCW (Lounge Chair Wood) 22
Eames, Ray 155
Eiffel Tower, Paris 128, 136
em 15, 16, 17, 61
em dashes 61
em spaces 15, 16, 61
emphasis 61, 169, 220
en 16, 61
en dashes 16, 61
en spaces 61
end matter *see* back matter
Euclid 18
executive (paper size) 61

F

Facetti, Germano 111
Fibonacci sequence 22, 61
fiddler crab 134
fields 56, 57
figure 61
figure-ground 62, 144, 145, 208
 ambiguous 58
 figure-ground reversal 68
 simple 69
flatfish 134
flow 62, 160, 214
flowing rhythm 68, 160
flowlines 54, 55, 62, 92
flush alignment 58
flush left alignment 58, 168, 169
flush right alignment 58, 168
focal points 62
folio (book size) 41, 42, 62
folio (page layout) 62
foot margins 50, 62
footers 62
 running footers 69
fore-edges 50, 62
form 62, 154, 158, 212
formal balance *see* symmetry
format 62

Fortuny, Mariano 155
Fournier, Pierre Simon 15
front matter 62

G

Gertsner, Karl 121
Gill, Eric 131
Girard, Alexander 155
Glass, Philip 136
golden section (divine proportion) 17, 18, 19, 20, 24, 63
golden section rectangles 20, 21
golden section spirals 22, 63
Graham, Martha 136
Great Pyramid, Giza 17
grid systems 63, 73
 anatomy of 45, 45, 47
 asymmetric 59, 78, 96, 98, 188
 baseline 59, 102, 103, 190
 compound 60, 112, 113, 194
 hierarchical 63, 106, 107, 192
 manuscript 65, 78, 79, 183
 Marber 65, 110
 modular 65, 92, 93, 186
 symmetrical 69, 82, 83, 184
 double-column 69, 83, 86, 88
 multiple-column 69, 83, 88, 90
 single-column 69, 83, 84
Grid Systems for Graphic Design (Müller-Brockmann) 75
ground 63, 145 *see also* figure-ground Guggenheim Museum, New York 136
Gutenberg, Johannes 24, 27, 74
gutters 50, 56, 57, 63, 78

H

Hambidge, Jay 25
“handedness” 134
hang lines 63
Hawks, Nelson C. 14
head margins 50, 63
headers 63
 running headers 69
Hemenway, Priya 18
Henion, F.H.K.: *Top Graphic Design* 121
Herald, The (newspaper) 76
hierarchical grid systems 63, 106, 107, 192
hierarchy 63, 169, 220
Hochschule für Gestaltung-HfG Ulm 146

Hofmann, Armin [121](#), [140](#)
Hohlwein, Ludwig [156](#)
horizontal symmetry [63](#), [129](#)
Huber, Max [126](#), [146](#)

I

Ictinus [20](#)
illusory forms [158](#)
imposition [63](#)
imposition
 plans/overviews [63](#), [153](#)
incunabula [64](#), [182](#)
indents [64](#)
International Typographic Style [75](#), [92](#), [140](#), [146](#)
ISO standard paper sizes [37](#)
isometric projections [64](#), [159](#)
italics [173](#)
Itten, Johannes [146](#)
Ive, Jonathan: Apple iPod [22](#)

J

Jeanneret, Charles-Edouard *see* Le Corbusier
jump [64](#)
junior legal (paper size) [64](#)
justification [64](#)
justified alignment [58](#), [169](#)
juxtaposition [64](#)

K

Kandinsky, Wassily [146](#)
kerning [16](#)
Klee, Paul [126](#), [133](#), [146](#)

L

Laga Company advertising (Zwart) [135](#)
large crown (paper size) [64](#)
LCW (Lounge Chair Wood) (Eames) [22](#)
Le Corbusier (Charles-Edouard Jeanneret): *Le Modulor* [34](#), [64](#), [75](#), [126](#)
leaves [64](#)
ledger (paper size) [64](#)
left-justified alignment *see* flush left alignment
legal (paper size) [64](#)
Leonardo da Vinci *see* Da Vinci, Leonardo
Leonardo of Pisa [22](#)
letter (paper size) [64](#)
letter spacing [16](#), [17](#)

letterforms, upper/lower case [171](#)
Leuppi, Leo [126](#), [146](#)
line measure *see* columns, width
linear perspective *see* one-point perspective
Lissitzky, El [133](#)
live areas [65](#)
location of visual elements [65](#), [124](#), [174](#)
Lohse, Richard Paul [126](#), [146](#)
lowercase letterforms [171](#)
Lustig, Alvin [155](#)

M

Maldonado, Tomas [146](#)
manuscript grid systems [65](#), [78](#), [79](#), [183](#)
Marber grid systems [65](#), [110](#)
marginalia [65](#)
margins [50](#), [51](#), [65](#)
 back-edge [50](#), [59](#)
 foot [50](#), [62](#)
 head [50](#), [63](#)
 manuscript grids [78](#), [79](#)
 multiple-column grids [89](#)
 single-column grids [83](#)
markers [56](#), [57](#), [65](#)
mass [134](#)
Massachusetts Institute of Technology (MIT): posters [121](#)
mastheads [65](#)
measure [65](#) *see also* columns, width
metric system [15](#), [65](#)
Michelangelo [17](#)
millimeters [65](#)
modular grid systems [65](#), [92](#), [93](#), [186](#)
modules [54](#), [55](#), [65](#)
Le Modulor [34](#), [64](#), [75](#)
Moholy-Nagy, László [126](#)
moiré patterns [66](#), [157](#)
montage [66](#)
Monza race posters (Huber) [126](#)
Morris, William [155](#)
mosaics [66](#), [157](#)
Moser, Koloman [155](#)
Mouron, Adolphe *see* Cassandre, A. M.
movement [66](#), [125](#), [198](#)
Mozart, Wolfgang Amadeus [25](#)
Müller-Brockmann, Josef [74](#), [121](#)
 Grid Systems for Graphic Design [75](#)

N

narwhal 134
nautilus shell 20, 22
negative (white) space 70, 162, 175
New Typography, The (Tschichold) 75, 130, 133, 135, 140
Notre Dame Cathedral, Paris 128

O

objective scale 66, 177
octavo (book size) 41, 42, 66
odd numbers 33
one-point (linear) perspective 65, 165
owls 134

P

pacing 66, 152
pacing and sequence 210
Pacioli, Luca: *De divina proportione* 18
pages 66
pagination 66
paper sizes
 ISO standard 37
 US and Canadian 39
Parthenon, Athens 17, 25, 27
passe partout 66
pattern 66, 154, 212
Penguin Book designs
 Marber 110
 Tschichold 130
perspective 165
 atmospheric 59, 165, 166
 one-point (linear) 65, 165
 two-point (planar) 59, 166, 167
Phidias 20
photomontage 66
physical space 66, 164
pica ems 16
picas 14, 16, 67
pictorial space 67, 164
Plakastil style 156
plan oblique *see* axonometric projections
planar perspective *see* two-point perspective
points 14, 67
position of visual elements 65, 124, 174
PostScript 15, 16, 67

preferred numbers [32](#), [67](#)
printing documents [154](#)
progressive rhythm [68](#), [161](#)
projections
 axonometric [59](#), [159](#)
 isometric [64](#), [159](#)
proportion [67](#)
proportional
 measurement systems [17](#)
proximity [67](#)
psychological space [67](#), [164](#)
pyramids [17](#), [182](#)

Q

quarto format [41](#), [42](#), [67](#)

R

radial balance [67](#), [123](#)
ragged left alignment *see* flush left alignment
ragged right alignment *see* flush right alignment
rails [67](#)
ranged alignment [58](#)
rational spacing *see* Fibonacci sequence
REA (Rural Electrification Administration): posters [163](#)
real forms [158](#)
recto [68](#), [83](#)
reflective symmetry [68](#), [128](#)
regular rhythm [68](#), [160](#)
relative measurement systems [15](#), [68](#)
Renard numbers [32](#), [68](#)
 asymmetrical grid [33](#)
 symmetrical grid [32](#)
Renner, Paul [133](#)
repetition [68](#), [125](#), [157](#)
reviewing documents [154](#)
rhythm [68](#), [125](#), [160](#), [214](#)
right justified alignment *see* flush right alignment
“rivers” [169](#)
root rectangles *see* dynamic rectangles
Rosarivo, Raúl: *Divina proporción tipográfica* [24](#)
rotative symmetry [68](#), [129](#)
rows [68](#)
royal (paper size) [68](#)
Rubin’s vase [58](#), [147](#)
Ruder, Emil [74](#), [140](#)
rule of thirds [33](#), [34](#), [68](#)

running footers 69
running headers 69
Rural Electrification Administration (REA): posters 163

S

Sachplakat style 156
Sant'Apollinare Nuovo, Ravenna 182
scale 69, 169, 177, 220
objective 66, 177
subjective 69, 177
Scherrer, Hermann 156
Schlemmer, Oskar 146
section aurea *see* golden section
Seltz, Peter 146
sequencing 152, 210
Sewell, John 111
shade 159
Shakespeare, William: *The Tragedy of King Lear* 131
shape 69, 123
signatures 69
simple figure-grounds 69
size of visual elements 175
small-caps 171
Sottsass, Ettore 127
space 69, 161, 216
 actual 58, 162
 negative (white) 70, 162, 175
 physical 66, 164
 pictorial 67, 164
 psychological 67, 164
spatial zones 54, 55, 69, 92
special numbers 33
standard book sizes 41
Stijl, de 135, 140
Stone, Reynolds 131
Stonehenge, UK 22
Stradivari, Antonio 20
subjective scale 69, 177
Swiss School *see* International Typographic Style
symmetrical
 compositions 69, 120, 127, 200
symmetrical grid systems 69, 82, 83, 184
 double-column 69, 86, 88
 multiple-column 69, 83, 88, 90
 single-column 69, 83 84
symmetry

horizontal 63, 129
reflective 68, 128
rotative 68, 129
translative 70, 129
vertical 70, 129

T

tabloid (paper size) 69
Tchaikovsky, Peter Ilyich 136
tension 70, 136, 204
tessellation 70
texture 70, 124, 159
thirds, rule of 33, 34, 68
Times, The (newspaper) 182
tone 159
Top Graphic Design (Henrion) 121
top margins *see* head margins
Tragedy of King Lear, The (Shakespeare) 131
translative symmetry 70, 129
Tschichold, Jan 27 *The New Typography* 75, 130, 133, 135, 140
Penguin Classics 130
two-point (planar) perspective 59, 166, 167
typefaces
 mixing 173
 style/weight 175

U

Unimark International 76
United States Capitol, Washington 128
United States paper sizes 39
United States standard book sizes 42
units 16, 70
unity 70
upper case letterforms 171

V

value 70, 123
Van de Graaf Canon 25, 28, 70
vanishing points 167
verso 70, 83
vertical symmetry 70, 129
Vignelli, Massimo 76
Villard diagrams 27, 30, 70
Virgil: *Aeneid* 25
visual cues 176
Vitruvian Man 6, 18

Vitruvius [18](#)

W

websites [106](#)

weight [70](#), [124](#), [134](#)

 typefaces [175](#)

white (negative) space [70](#), [162](#), [175](#)

widows [70](#)

word spacing, multiple-column grids [89](#)

X

x-height [102](#)

Z

Zwart, Piet [133](#), [135](#)

Credits

About the Author

As Co-founder, Design Director, and Principal of Poulin + Morris Inc., Richard Poulin has directed visual communications programs for clients including Brooklyn Botanic Garden, Brooklyn Museum, Carnegie Hall, William J. Clinton Presidential Foundation, Cornell University, Lycée Français de New York, Mandarin Oriental Hotel Group, Morgan Stanley, New-York Historical Society, New York Law School, The New York Public Library, Novo Nordisk, NPR, The Norman Rockwell Museum, School of American Ballet, Smithsonian Institution, Syracuse University, Vassar College, W Hotels and Resorts, and Yale University.

His work has been published in periodicals and books worldwide, is in the permanent collection of the Library of Congress, and has received awards from American Institute of Architects (AIA); The American Institute of Graphic Arts (AIGA); *Applied Arts*; Art Directors Clubs of New York, Los Angeles, and San Francisco; *Communication Arts*; *Creative Quarterly*; *Graphis*; *ID*; *Print*; Society for Experiential Graphic Design (SEGD); Society of Publication Designers; and Type Directors Club.

Richard is a Fellow of the Society for Experiential Graphic Design, the organization's highest honor, and a recipient of a research grant from the Graham Foundation for Advanced Studies in the Fine Arts. He is also the author of several award-winning books including *The Language of Graphic Design: An Illustrated Handbook for Understanding Fundamental Design Principles*; *Typography Referenced* (coauthor); and *Graphic Design + Architecture: A 20th-Century History*, all published by Rockport Publishers; and *Archigraphia Redux*, published by Graphis.

Since 1992, he has been an adjunct professor at the School of Visual Arts in New York City and was formerly an adjunct professor at The Cooper Union. Richard is a frequent lecturer and visiting professor at universities and educational institutions including Carnegie-Mellon University, The Maryland Institute College of Art, Massachusetts College of Art, North Carolina State University, Syracuse University, University of the Arts, University of Cincinnati, and University of Washington.

Acknowledgments

This book is dedicated to Dana Morris, my husband and partner in life and work.

THIS BOOK IS DEDICATED TO DOUG MORRIS... my husband and partner in life, work, and love, who has always given me the time, freedom, and support to pursue my dreams.

Design School: Layout would not have been possible without the assistance and generous contributions of so many people. My sincere appreciation to all of the graphic designers, educators, students, and colleagues for generously contributing examples of their work.

A special thanks to Rockport Publishers for their continued support.

And, to James Evans, my editor and associate publisher at Quid Publishing (London) for his invaluable guidance and insights.

To Erik Herter and Derek Koch, my colleagues at Poulin + Morris Inc., who helped design this volume with a level of detail and nuance that I did not fully appreciate when we started this project. Their invaluable insights, contributions, and creativity in the organization and design of this volume are deeply appreciated.

And as always, to my students—past, present, and future, who continue to inspire and challenge me every day.

Colophon

Design School: Layout was designed and typeset by Poulin + Morris Inc., New York, New York. Digital type composition, page layouts, and type design were originated on Apple iMac computers, utilizing Adobe InDesign cS6, Version 8.1 software.

The text of this book was set in Retina (Tobias Frere-Jones, 2016) and TheSerif (Lucas de Groot, 1994), produced by Frere-Jones Type, Brooklyn, New York and Lucas Fonts, Berlin, Germany, respectively.

Credits

Author and Design Director: Richard Poulin Creative Director and Designer: Erik Herter Designer: Derek Koch



Brimming with creative inspiration, how-to projects, and useful information to enrich your everyday life, Quarto Knows is a favorite destination for those pursuing their interests and passions. Visit our site and dig deeper with our books into your area of interest: Quarto Creates, Quarto Cooks, Quarto Homes, Quarto Lives, Quarto Drives, Quarto Explores, Quarto Gifts, or Quarto Kids.

© 2018 Quarto Publishing Group USA, Inc.

First Published in 2018 by Rockport Publishers, an imprint of
The Quarto Group,
100 Cummings Center, Suite 265-D,
Beverly, MA 01915, USA.
T (978) 282-9590
F (978) 283-2742
QuartoKnows.com

All rights reserved. No part of this book may be reproduced in any form without written permission of the copyright owners. All images in this book have been reproduced with the knowledge and prior consent of the artists concerned, and no responsibility is accepted by producer, publisher, or printer for any infringement of copyright or otherwise, arising from the contents of this publication. Every effort has been made to ensure that credits accurately comply with information supplied. We apologize for any inaccuracies that may have occurred and will resolve inaccurate or missing information in a subsequent reprinting of the book.

Rockport Publishers titles are also available at discount for retail, wholesale, promotional, and bulk purchase. For details, contact the Special Sales Manager by email at specialsales@quarto.com or by mail at The Quarto Group, Attn: Special Sales Manager, 401 Second Avenue North, Suite 310, Minneapolis, MN 55401, USA.

Digital edition: 978-1-63159584-4
Hardcover edition: 978-1-6315-9319-2

Library of Congress Cataloging-in-Publication Data is available

Design: Poulin + Morris Inc.