

A close-up photograph of a person's hands resting inside a white, shallow bowl. The person has dark skin and is wearing several rings: a silver ring with a white stone on the left ring finger, a gold ring on the left middle finger, a silver ring with a blue stone on the right ring finger, and a gold ring on the right middle finger. The left forearm has several tattoos, including a large starburst design, a vertical line with dots, and a cross-like symbol. The background is dark, and the lighting is dramatic, highlighting the hands and the bowl.

ANARZ™

ARTISTRY . HERITAGE . STILLNESS



ABOUT ANARA

Anara was born from a quiet observation: that in the pursuit of beauty, the most intimate details are often overlooked. We saw a space within the home that deserved more reverence, where design could transcend utility and offer something far more human. In a world of mass production, Anara returns to the elemental.

Guided by India's rich legacy in materials like marble and inspired by global, sculptural design, our pieces are not just objects. They are forms shaped with care. Forms that hold water, yes, but also memory, stillness, and ritual.

At Anara, we design with presence and intention, believing that every space deserves objects that mean something. We invite you into a world of slow, thoughtful living, where design is not decoration, but devotion.

CRAFTSMANSHIP

marble

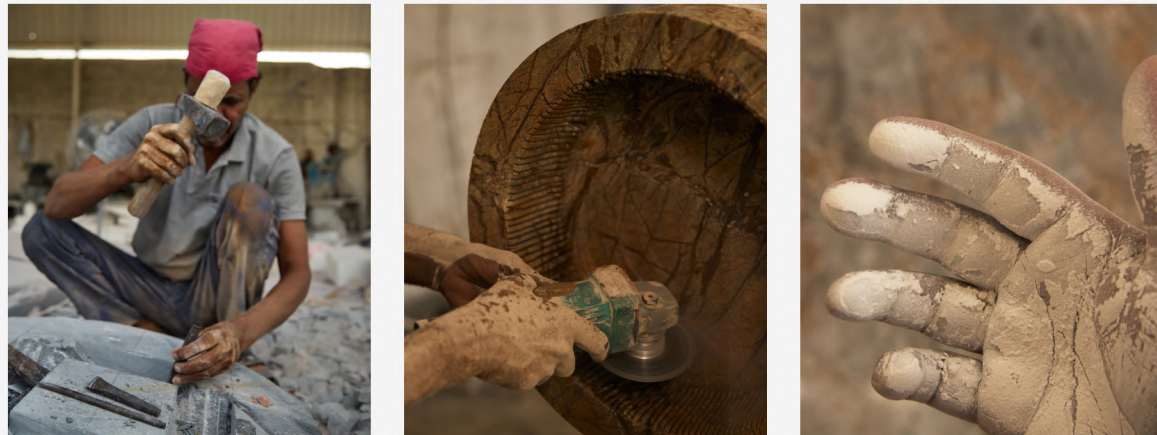

Our story begins where mass production ends. At Anara, each piece is handcrafted in India using natural materials that carry within them centuries of culture, marble and concrete. We work closely with skilled craftspeople who understand both material and meaning, shaping every piece with equal parts intuition and technique. What defines us is not just what we make, but how we imagine it.

concrete



We don't see our basins as fixtures, but as sculptural expressions. Each one is a quiet architecture of presence: a form that invites pause, and a surface that carries the imprint of hand, history, and intention. With a curated palette of finishes and custom options, we offer more than function; we offer form that feels. This is where design returns to the body, the earth, and the soul.

MATERIAL PHILOSOPHY

Drawn from India's oldest quarries, our **MARBLE** reflects a deep cultural lineage, long associated with temples, sculpture, and sanctity. Each block is hand-finished by skilled artisans, revealing the quiet drama of its veining and texture.

The marble variations we work with include:



BANSWARA
WHITE

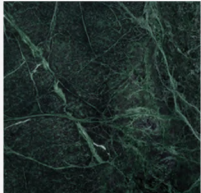

UDAIPUR
GREEN

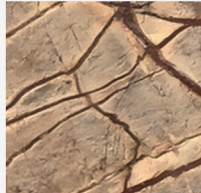

BIDASAR
BROWN



JAISALMER
YELLOW

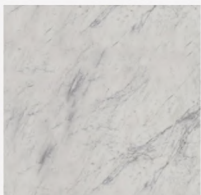

PURPLE
BANSWARA

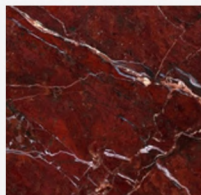

ROSSO
LEVANTO

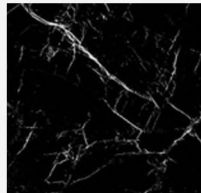

BLACK
MARQUINA

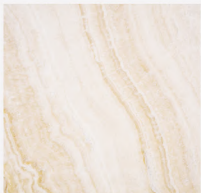

MAKRANA
PINK

Our **CONCRETE** is cast in small batches using proprietary mixes, often with natural pigments and terrazzo infusions. It allows us to create forms that feel modern, meditative, expressive and understated.

The concrete variations we work with include:

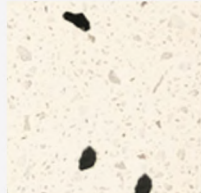

WHITE
TERRAZZO

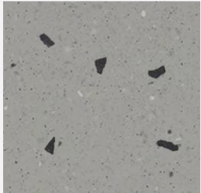

GREY
TERRAZZO

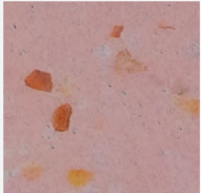

PINK
TERRAZZO

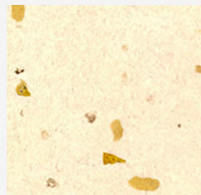

IVORY
TERRAZZO

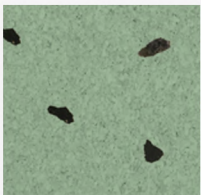

GREEN
TERRAZZO

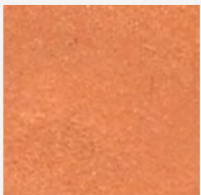

TERRACOTTA
SOLID
(HONED FINISH)



BLUE CONCRETE
SOLID
(HONED FINISH)

COLLECTIONS

CORE

Stambh.....	8
Tirtha.....	15
Lota.....	22
Sankira.....	26
Geru.....	30
Aasmani.....	32
Eka.....	34
Kalash.....	38
Garbha.....	41

ANARA CORE brings together the studio's essential forms, objects shaped for everyday ritual and long-term use. Rooted in material honesty and proportion, these pieces prioritise balance, function, and quiet presence. Designed to live effortlessly within daily routines.

ATELIER

Paatal.....	45
Meena.....	46
Kund.....	49
Kalash Sutra.....	50
Garbha Nidhi.....	52

ANARA ATELIER presents the studio's exploratory side, featuring limited, craft-intensive works shaped by process, narrative, and material experimentation. Stone becomes a medium for expression rather than repetition. Each edition is developed through hand-led techniques, resulting in sculptural objects that sit between function and form,

COLLECTIONS

MONOLITHS

Stambh.....	55
Fluted Monolith.....	56
Circular Monolith.....	59
Rekha.....	61
Grid Monolith.....	62
Relief Monolith.....	65

ANARA MONOLITHS extends the studio's ritual-driven language into grounded architectural forms. Shaped through rhythm, geometry, and material continuity, these monolithic bases are conceived as sculptural supports that integrate the basin into space, allowing object and architecture to exist as one restrained, cohesive presence.

A photograph of a traditional courtyard with a central well, a wooden door with a scalloped arch, and various pottery items on a ledge.

CORE

Form. Function. Quiet Presence.



S t a m b h

PILLAR OF TIME

Stambh draws from ancient architectural pillars, reinterpreting them as sculptural forms of stability and heritage. Rooted in structure, rhythm, and quiet monumentality, the collection balances the tactile strength of stone with refined detailing. Each piece carries a grounded presence, transforming contemporary spaces through endurance, restraint, and a sense of timeless legacy.

STAMBH column

The Stambh Column is a sculptural homage to India's ancient architectural pillars. Carved from natural stone, its tall, cylindrical form, etched with subtle vertical ridges, speaks of spiritual grounding and timeless strength. This piece is more than structural; it embodies heritage, stillness, and the silent passage of centuries.

Diameter × Height
445 mm × 860 mm
17.5 IN × 34 IN

100-120 kgs

Polished

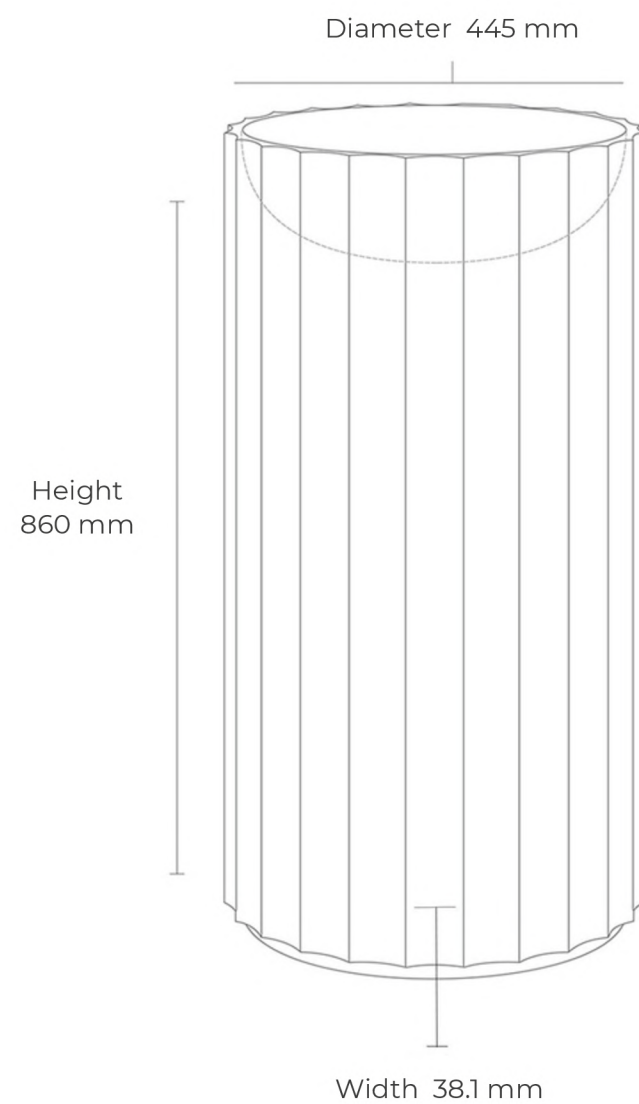

STAMBH COLUMN IN
BANSWARA WHITE



STAMBH VESSEL
IN JAISALMER



STAMBH vessel

The Stambh Vessel transforms the symbolic pillar into a functional, sculptural basin. Its refined form, drawn from temple architecture, captures the sacred geometry of endurance and ritual. Crafted with precision, its surface bears delicate linear carvings, softening its otherwise presence.

Diameter × Height
445 mm × 127 mm
17.5 IN × 5 IN

60 kgs

Polished

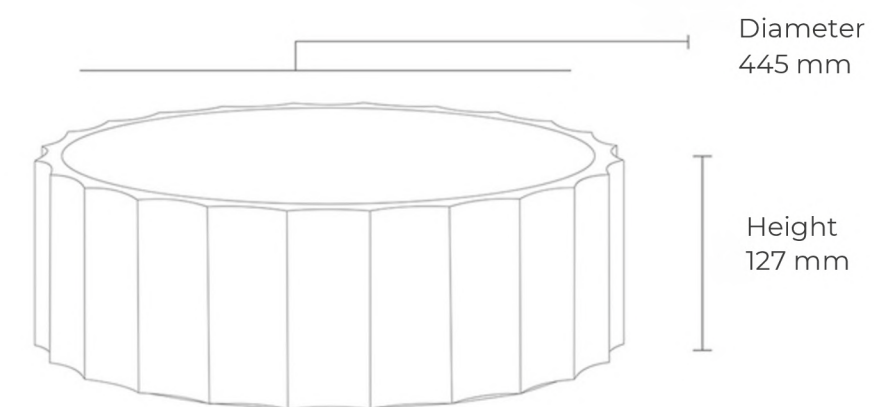

BANSWARA WHITE
COLUMN



BANSWARA WHITE
VESSEL



MAKRANA PINK
COLUMN



MAKRANA PINK
VESSEL



UDAIPUR GREEN
COLUMN



UDAIPUR GREEN
VESSEL



JAISALMER
YELLOW COLUMN



JAISALMER
YELLOW VESSEL



STAMBH VESSEL IN
BIDASAR BROWN



BIDASAR BROWN
COLUMN



BIDASAR BROWN
VESSEL



BLACK MARQUINA
COLUMN

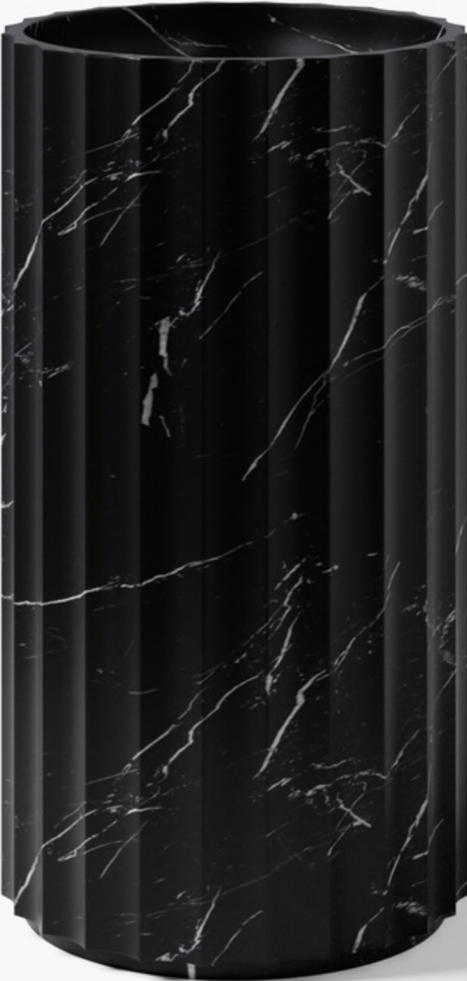

BLACK MARQUINA
VESSEL





Tirtha

THE SACRED FLOW

Tirtha draws from the sacred movement of flowing water, translated into sculptural stone through organic lines and rhythm. Inspired by the quiet force of erosion and natural flow, the collection explores smooth transitions, softness, and immersion. Calm yet grounded, Tirtha brings a sense of stillness, and fluid continuity into interiors.

TIRTHA column

Tirtha Column captures the silent dialogue between stone and water. Inspired by river-worn pebbles, its soft, organic silhouette speaks of centuries of natural erosion and sacred flow. Sculpted with reverence, it invites the eye and hand to follow its contours, evoking stillness and movement simultaneously.

Diameter × Height
480.06 mm × 850.9 mm
18.9 in × 33.5 in

100-120 kgs

Polished

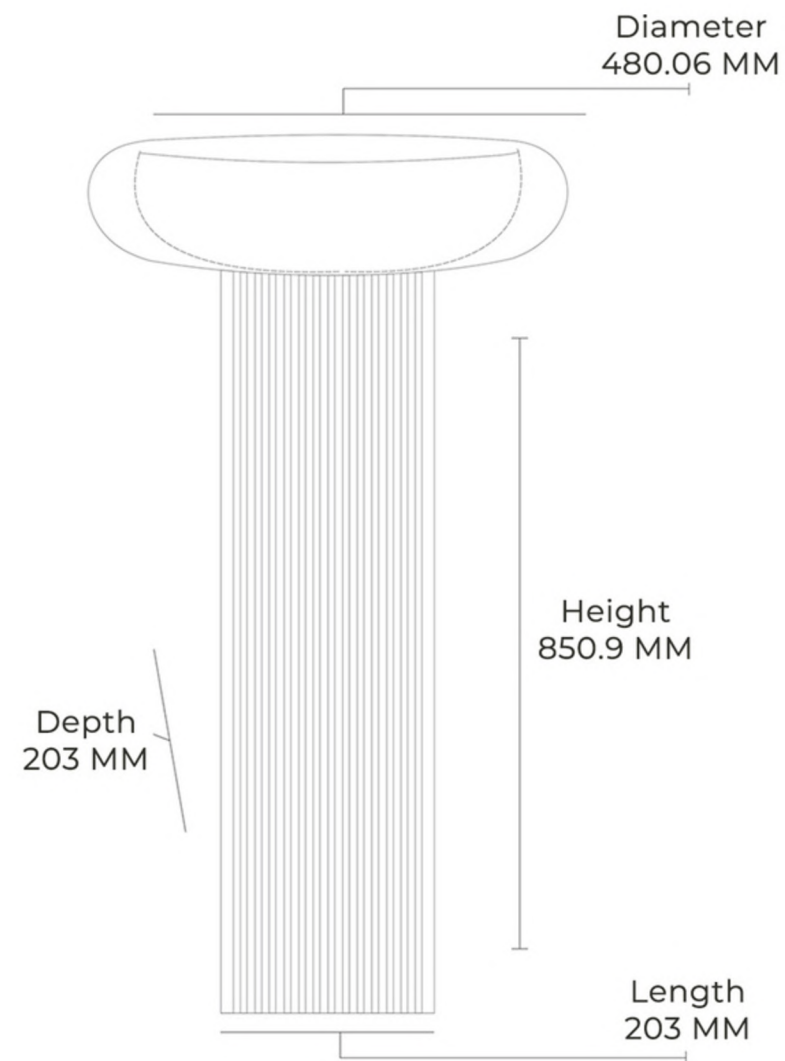



TIRTHA VESSEL IN
UDAIPUR GREEN

TIRTHA vessel

The Tirtha Vessel distils the sacred dance of water and stone into a tactile, meditative form. Shaped with flowing curves and softened edges, it mirrors river stones lovingly carved by time. Each vessel embodies continuity, resilience, and stillness. Its smooth surface invites gentle interaction, turning the simple act of touch into a quiet ritual.

Diameter × Height
480.06 mm × 114.3 mm
18.9 in × 4.5 in

60 kgs

Polished

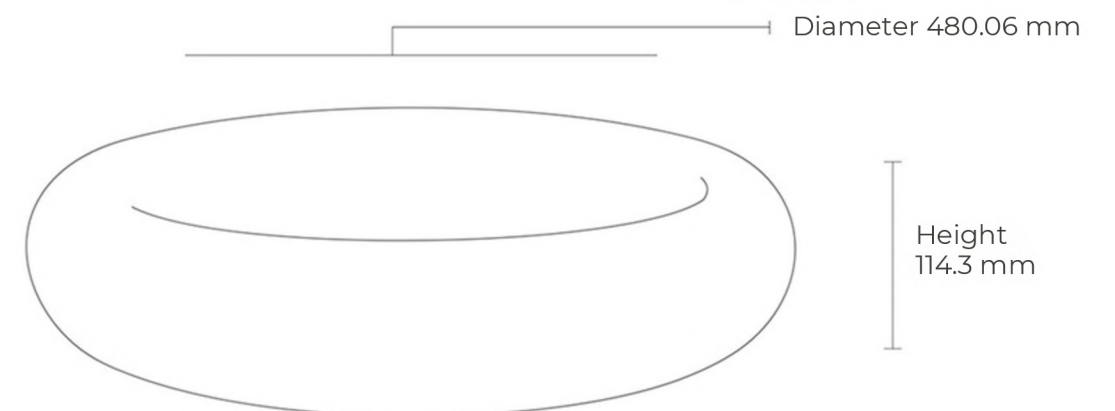

BANSWARA WHITE
COLUMN



BANSWARA WHITE
VESSEL



MAKRANA PINK
COLUMN



MAKRANA PINK
VESSEL



TIRTHA VESSEL IN
MAKRANA PINK



BIDASAR BROWN
COLUMN



BIDASAR BROWN
VESSEL



UDAIPUR GREEN
COLUMN



UDAIPUR GREEN
VESSEL

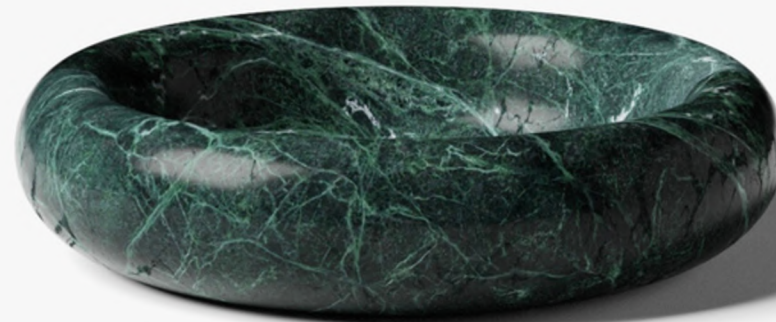



PURPLE BANSWARA
COLUMN



PURPLE BANSWARA
VESSEL



TIRTHA COLUMN IN
PURPLE BANSWARA

L o t a

THE VESSELS OF NOSTALGIA

The Lota column draws from the legacy of India's ancient ritual vessel, known for its fluid curves and symbolic presence. Reinterpreted in sculptural stone, the form balances softness, proportion, and stillness. With its rounded base and tapering silhouette, Lota brings quiet heritage, intention, and meditative calm into contemporary spaces.

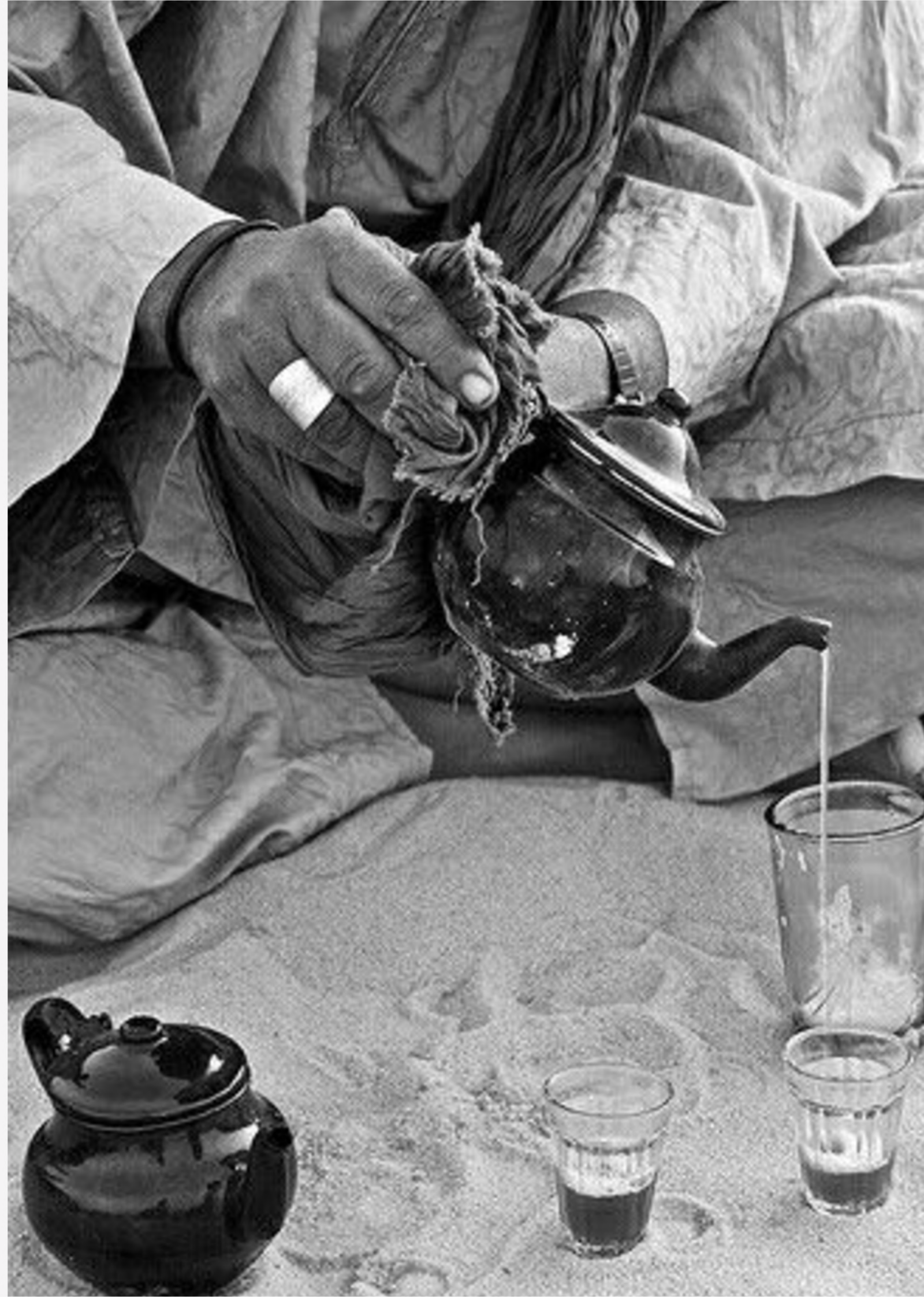

LOTA COLUMN IN
BANSWARA WHITE

LOTA column

Rooted in ancient utility and ritual, the Lota basin draws from traditional Indian vessel forms. Curved, compact, and quietly symbolic, it reinterprets this lineage through a serene contemporary silhouette. Soft in presence yet grounded in meaning, Lota transforms everyday use into moments of pause, reflection, and tactile connection.

Diameter × Height
356 mm × 838 mm
14 in × 33 in

100-120 kgs

Polished

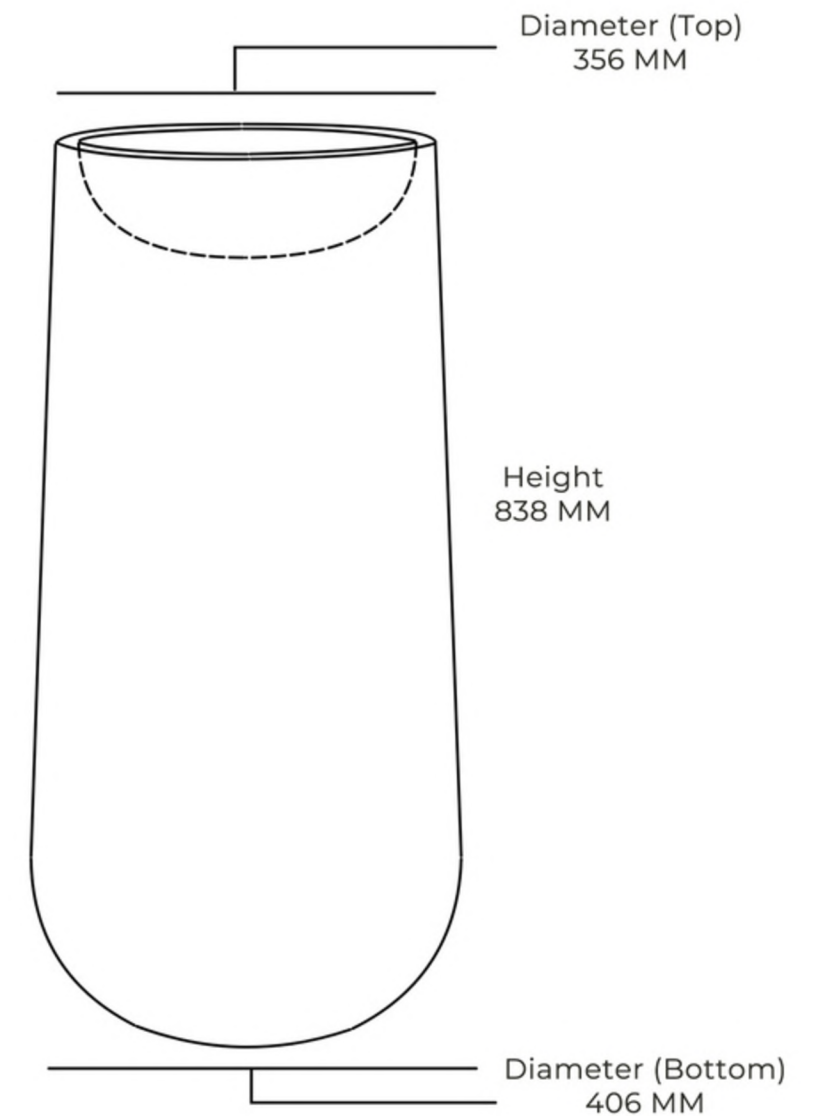



BANSWARA WHITE
COLUMN



UDAIPUR GREEN
COLUMN



JAISALMER
COLUMN



MAKRANA PINK
COLUMN



LOTA COLUMN IN
MAKRANA PINK



Sankira

SCATTERED STORIES OF NOSTALGIA

Sankira draws from fragments, ruins, and surfaces shaped by time. Rooted in nostalgia and poetic imperfection, the collection embraces asymmetry, texture, and irregularity to create forms that feel discovered rather than made. Quietly expressive and intimate, Sankira transforms interiors into layered memory spaces where scattered elements exist in restrained harmony.

RAASA vessel

The Raasa Vessel celebrates memory through terrazzo and fragmented texture. Its smooth circular form is scattered with playful, imperfect specks that evoke familiarity and everyday nostalgia. Soft, tactile, and timeless, Raasa transforms the basin into a quiet space for recollection and ritual, where material, emotion, and sculptural presence gently converge.

Diameter × Height
406 mm × 127 mm
16 in × 5 in

30 kgs

Polished

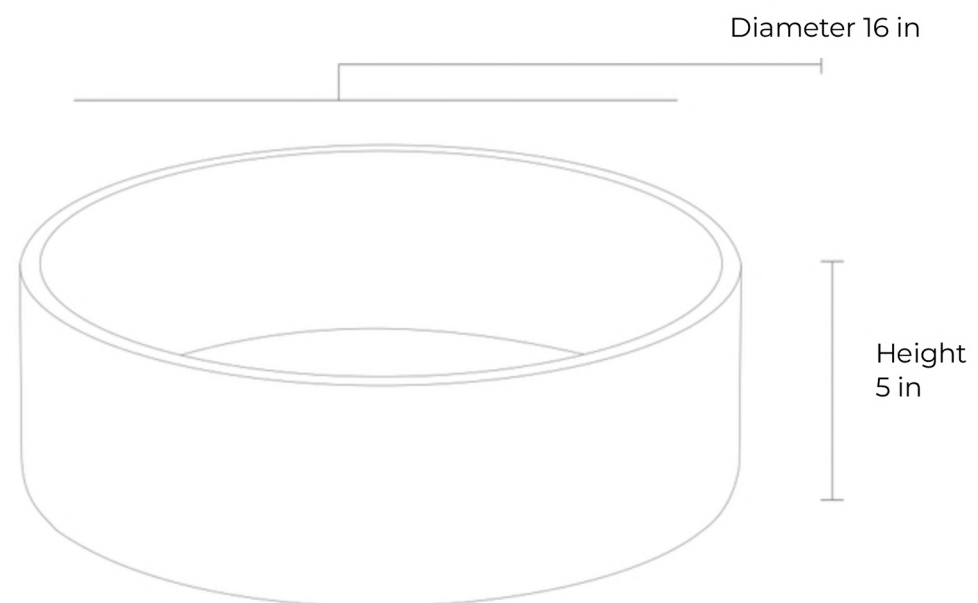

SANKIRA RAASA VESSEL
IN TERRAZZO GREY



TERRAZZO WHITE



TERRAZZO IVORY



TERRAZZO GREY



TERRAZZO PINK



TERRAZZO GREEN

Geru

THE SOUL OF EARTH

Geru draws from the richness of earth and the warmth of natural red soil pigments. Rooted in traditional materiality, the collection explores tactile surfaces, organic tones, and grounded simplicity. Warm, familiar, and quietly expressive, Geru brings a lived-in quality to spaces shaped by authenticity, sun-soaked textures, and material depth.



KORA vessel

The Kora Vessel embodies the grounded spirit of earth through solid concrete and a tactile, hand-worked finish. Its rounded form recalls ancient rituals and elemental landscapes, celebrating material honesty and craft. Raw yet composed, Kora transforms everyday utility into a quiet artefact of memory, touch, and enduring human connection.

Diameter × Height
406 mm × 127 mm
16 in × 5 in

30 kgs

Honed

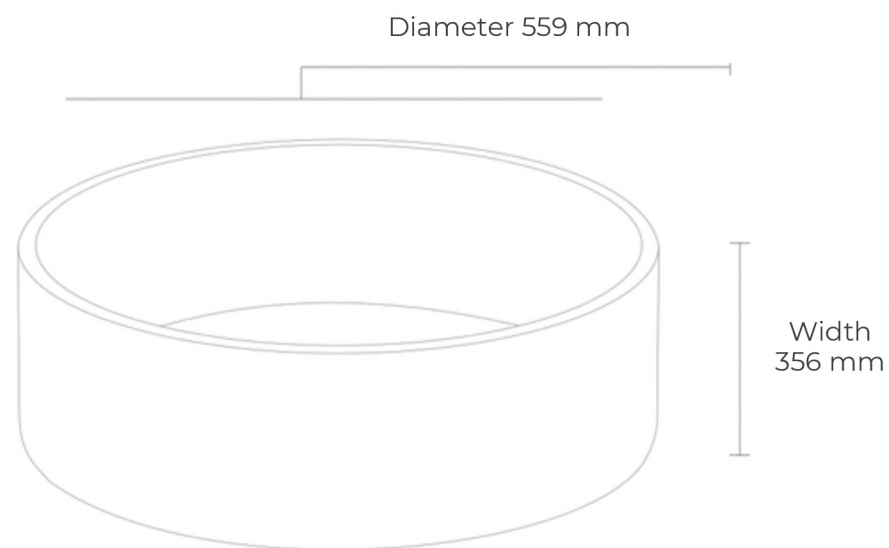

TERRACOTTA SOLID

Aasmani

WHISPER OF SKY



Aasmani reinterprets stone through softness, lightness, and atmospheric calm. Inspired by shifting skies and early morning mist, the collection features lifted forms, rounded edges, and airy tones that create a quiet presence. Balancing minimalism with emotion, Aasmani transforms interiors into serene spaces shaped by stillness, restraint, and reflection.

ANANT vessel

The Anant Vessel captures the calm of open sky through its soft, expansive form. Crafted in solid concrete, its matte surface and rounded geometry evoke stillness and inward reflection. Grounded in material yet gentle in presence, Anant transforms everyday rituals into meditative moments, bringing quiet calm into contemporary and reflective spaces.

Diameter × Height
406 mm × 127 mm
16 in × 5 in

30 kgs

Polished

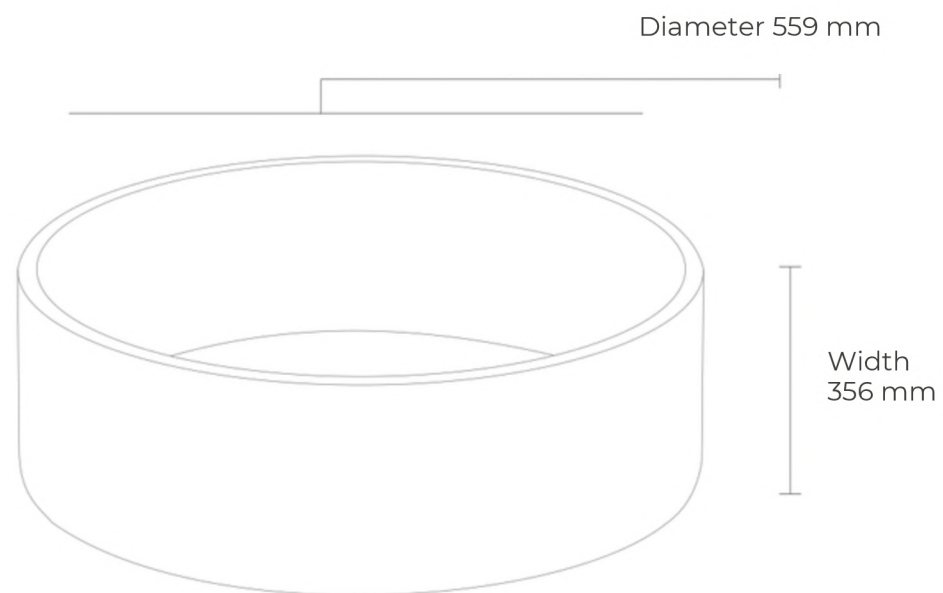

BLUE SOLID

E k a

THE SINGULAR FOCUS

Eka returns to the essential, where every curve and surface honours stone in its purest form. Defined by restraint and clarity, the collection transforms solid stone into contemplative objects of stillness. Rejecting excess, Eka brings raw refinement to modern spaces, where each piece exists as both sculpture and quiet statement.



EKA vessel

Eka is a sacred vessel sculpted from a single block of stone, inspired by the timeless form of the kumbha. Seamless curves and textured surfaces reflect ancient craftsmanship and material depth. Meditative, tactile, and sculptural, Eka transcends function, becoming a quiet expression of heritage, continuity, and enduring sacred design.

Diameter × Height
424 mm × 450 mm
16.69 in × 17.72 in

80 kgs

Polished

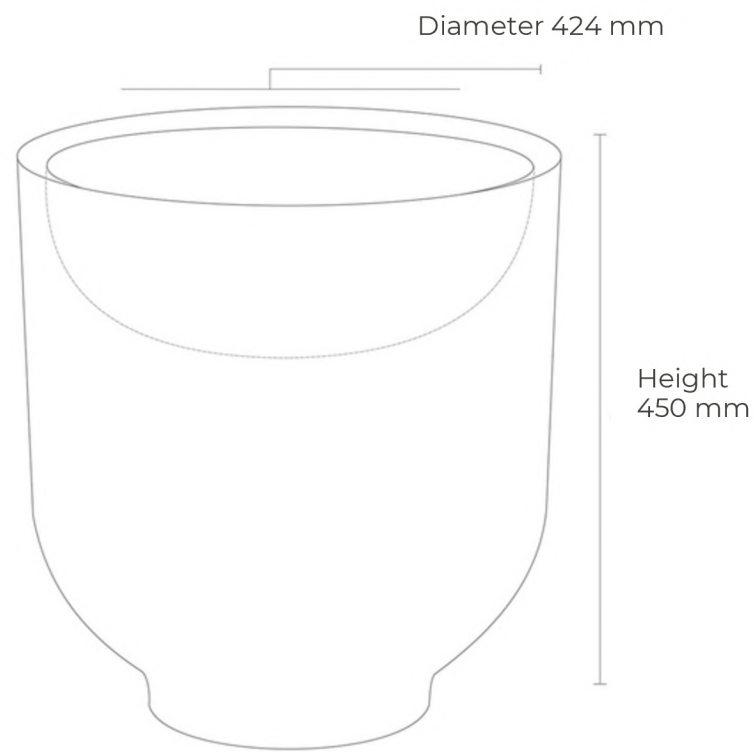

EKA VESSEL IN
UDAIPUR GREEN





BANSWARA WHITE
VESSEL



MAKRANA PINK
VESSEL



JAISALMER YELLOW
VESSEL



UDAIPUR GREEN
VESSEL



BLACK MARQUINA
VESSEL



RED LAVANTE
VESSEL



EKA VESSEL IN
RED LAVANTE



Kalash

THE QUIET OFFERING

Kalash draws from one of India's enduring ritual forms, where the vessel signifies offering, continuity, and care. Translated into contemporary stone, the collection explores balance, fullness, and quiet proportion. Each form holds water not merely as utility, but as presence, carrying a sense of ritual gently into everyday life.

KALASH vessel

Kalash draws from one of India's enduring ritual vessels, historically linked to offering and continuity. Reinterpreted in marble, the form retains its balanced fullness through restraint and proportion. The rounded body allows light to move gently across the stone, revealing depth through materiality and bringing quiet ritual presence into everyday spaces.

Diameter × Height
356 mm × 152 mm
14 in × 6 in

80 kgs

Polished

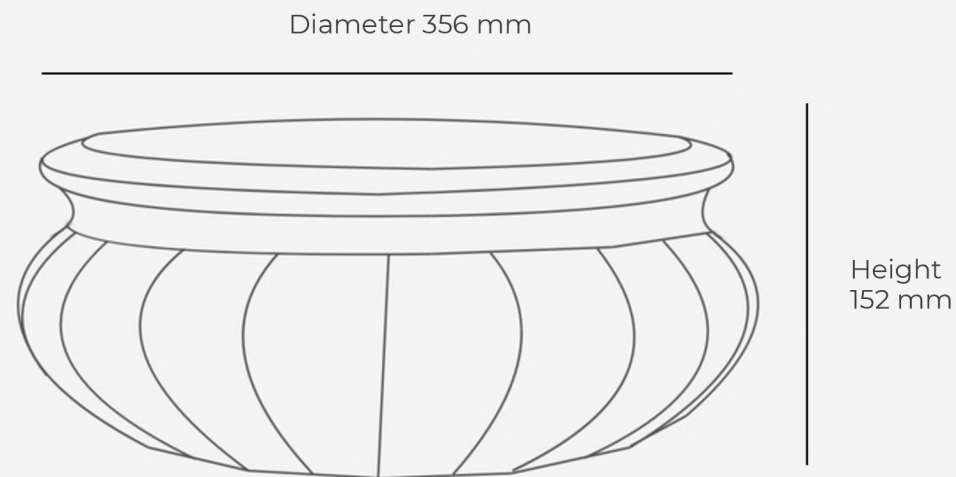



MAKRANA PINK



BIDASAR BROWN



UDAIPUR GREEN



JAISALMER YELLOW

Garbha

THE INNER STILLNESS



Garbha draws from traditional earthen vessels that hold light within, rooted in the idea of containment rather than display. Translated into stone, the collection explores softened mass, inner volume, and calm enclosure. Through stillness and balance each vessel is designed to hold space rather than seek attention.

GARBHA vessel

Garbha is conceived as a vessel of inwardness. Named after the Garbha Deep, an earthen form that carries light within, it draws from the idea of containment rather than display. Its rounded mass and softened profile gather water inward, allowing meaning to emerge through stillness, balance, and quiet.

Top Diameter × Bottom Diameter × Height
356 mm × 406 mm × 140 mm
14 in × 16 in × 5.5 in

80 kgs

Polished

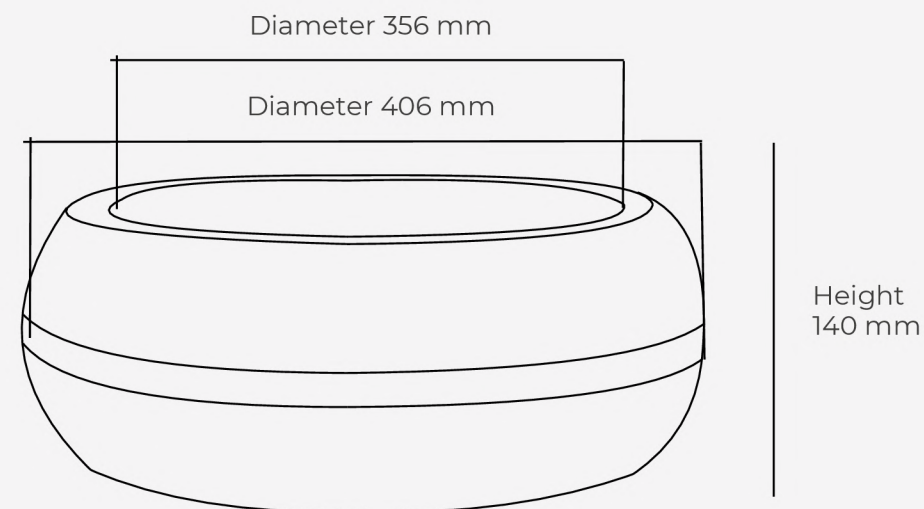

This edition was developed in-house at Anara, with contributions from Aishwarya Ghosh, a design student from NIFT Bhubaneswar, as part of Anara's initiative to support emerging design voices.





MAKRANA PINK



PURPLE BANSWARA

A workshop scene featuring various stone and metal objects. In the foreground, a large, shallow, light-colored stone bowl sits on a circular stone pedestal. To its left, a small table lamp with a glass globe is on another stone block. In the background, several tall, cylindrical stone pedestals are arranged, some with dark, faceted metal pieces hanging from them. To the right, a white stone fireplace mantel holds a few small objects, including a pointed metal piece. In the lower right, a small, round, light-colored ceramic pot sits on a stone block. The scene is lit with warm, natural light, creating soft shadows and highlighting the textures of the stone and metal.

ATELIER

Limited. Crafted. Material.

Paatal

A QUIET DESCENT

Paatal draws inspiration from India's ancient stepwells, architectural responses to water, time, and ritual descent. Reinterpreted through layered marble geometry, the collection translates this spatial logic into contemporary stone compositions. Viewed from above, each form reveals a rhythm, structured, grounded, and quietly immersive, echoing the depth and stillness of descent.



UNDERMOUNT BASIN

Paatal, designed as a undermount basin, is conceived as a study of depth. It is experienced primarily from above through layers, geometry, and measured descent rather than surface display. Inspired by India's ancient stepwells, PAATAL translates their architectural logic into contemporary stone.

Length x Width x Depth
559 mm x 356 mm x 152 mm
22 in x 14 in x 6 in

80 kgs

Polished

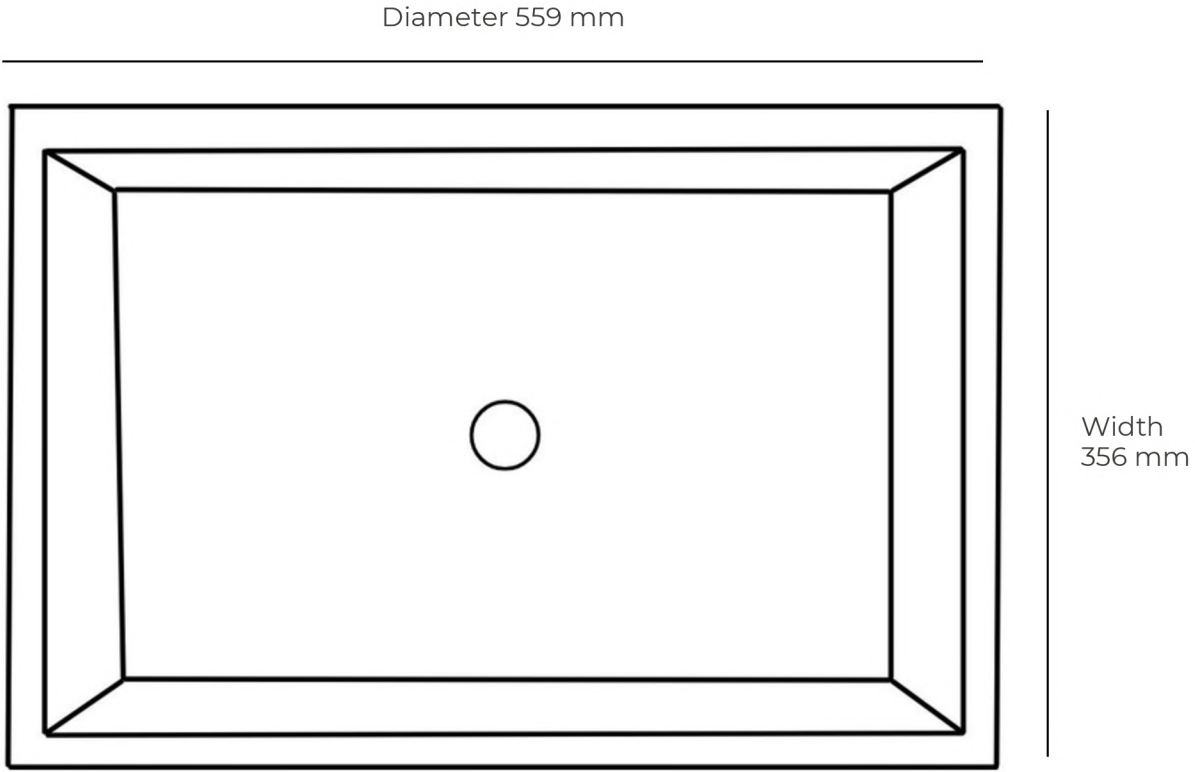

MEENA

Meena draws inspiration from the stepped geometry of India's historic stepwells, quietly referencing the rhythmic descents of Panna Meena ka Kund.

The pattern is conceived as architecture rather than ornament, built through layered inlay that creates a sense of depth and measured movement.

craft details

- Architectural inlay in marble (hand-cut, hand-set)
- Alignment based on stepped geometry; proportion-based repetition
- Surface finished and calibrated post-inlay for seamless plane integrity
- Designed for depth without surface relief; flush to stone

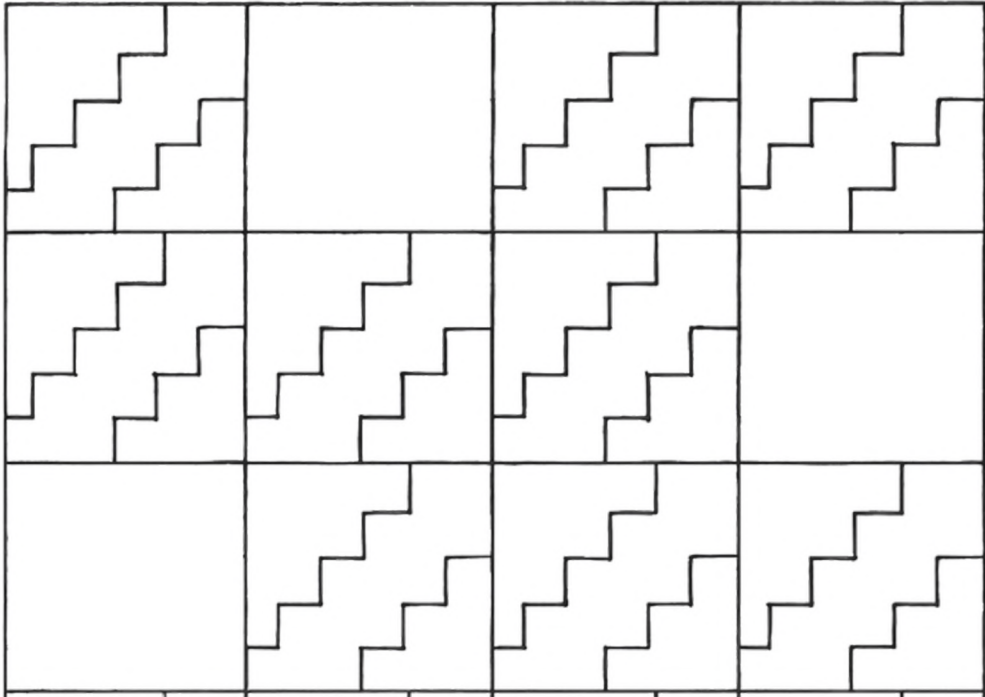



BASE MARBLE – BANSWARA WHITE
INLAY MARBLE – UDAIPUR GREEN

*Recommended for residential and luxury hospitality bathrooms,
including powder rooms and master bathrooms*



MEENA IN BANSWARA WHITE
& UDAIPUR GREEN



MEENA IN BANSWARA WHITE
& MAKRANA PINK



BASE MARBLE – BANSWARA WHITE
INLAY MARBLE – MAKRANA PINK

*Recommended for residential and luxury hospitality bathrooms,
including powder rooms and master bathrooms.*

K u n d

THE QUIET HOLD

Kund draws from India's long relationship with water as a settled presence. Designed for containment rather than movement, kunds held water with intention and care. Translated into contemporary stone, the Kund collection explores grounded ritual vessels shaped by mass, proportion, and inner volume, bringing the quiet dignity of held water into everyday spaces.

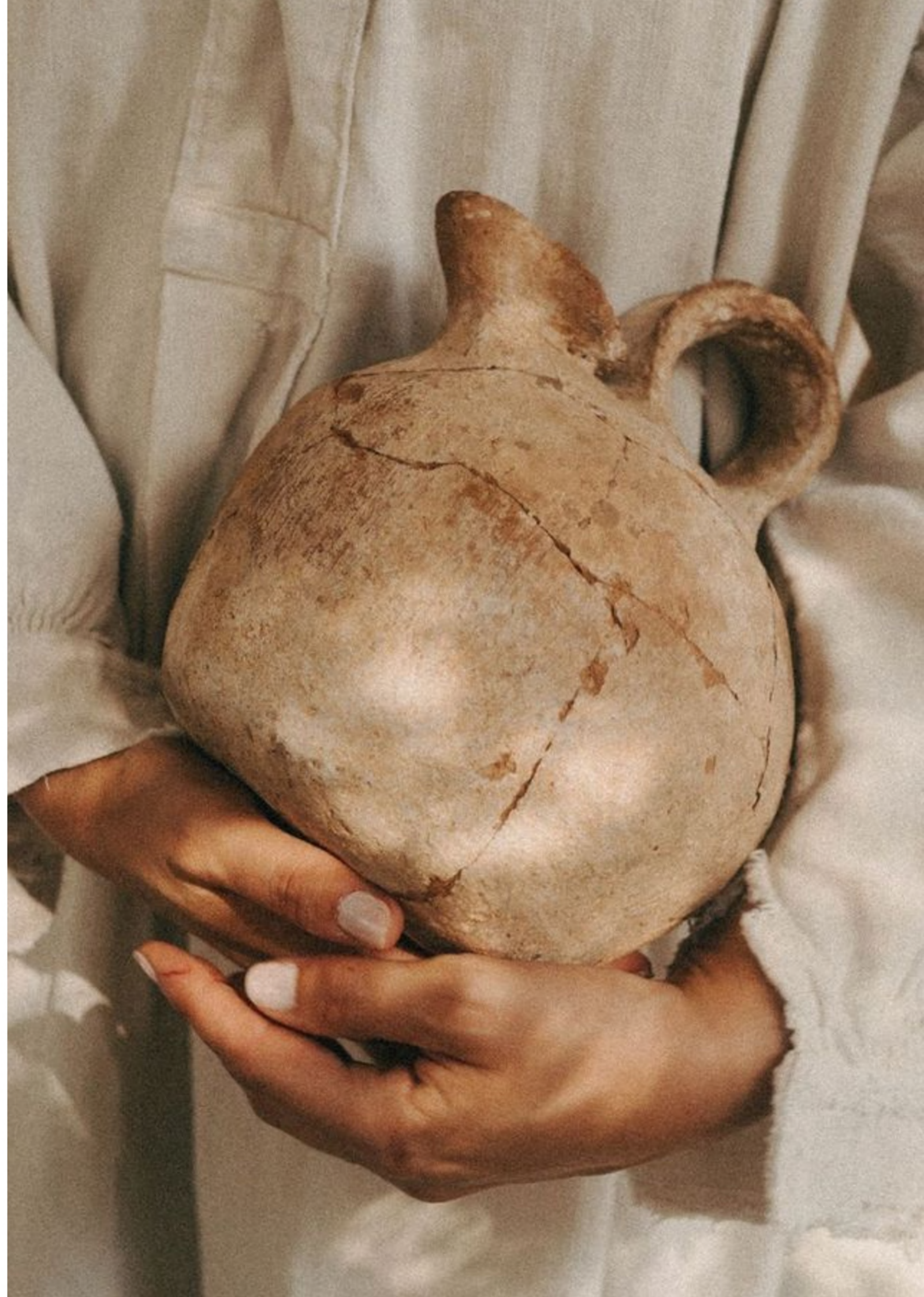

KALASH SUTRA

Kalash Sutra introduces a restrained inlay articulation to the vessel's surface. A measured sequence of inlay points encircles the body, referencing repetition, continuity, and the quiet discipline of ritual handling. Neither decorative nor symbolic, the inlay acts as a trace, marking where hands return and where use becomes habit. Material, light, and stillness remain primary.

Diameter x Height
356 mm x 152 mm
14 in x 6 in

80 kgs

Polished

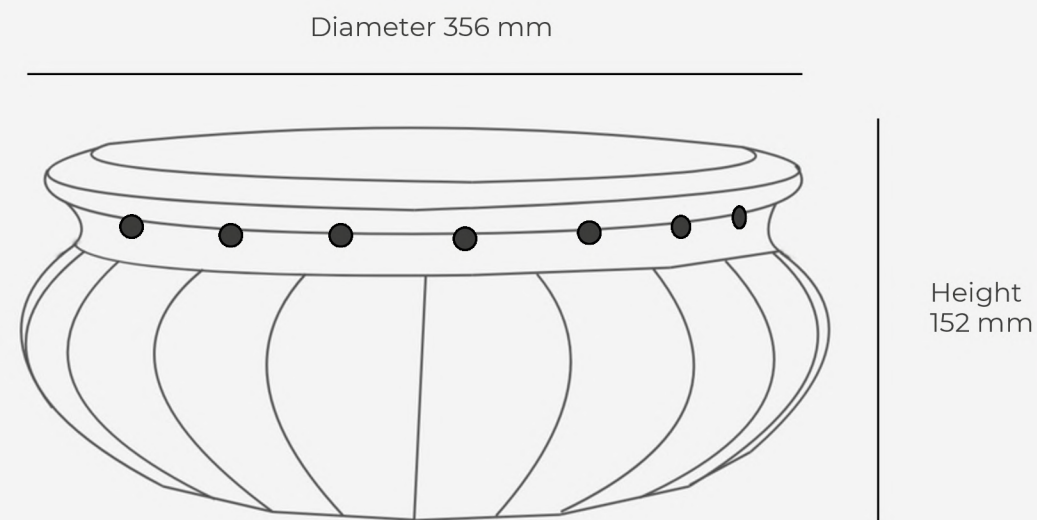

craft details

- Hand-cut marble inlay points are individually set along the vessel's circumference.
- Placement follows a measured rhythm guided by proportion rather than ornamentation or pattern.
- Each inlay sits flush with the stone surface, preserving tactile continuity.
- The form is refined post-inlay to maintain softness, repetition, balance, and material integrity.





KALASH SUTRA

GARBHA NIDHI

GARBHA Nidhi introduces restrained articulation to the vessel's surface. Vertical inlay lines suggest light gently finding its way outward from within, echoing the controlled emergence of inner illumination. Subtle and measured, the inlay does not decorate the form; it acts as a trace, reinforcing containment while allowing material and stillness to remain primary.

Top Diameter × Bottom Diameter × Height
356 mm × 406 mm × 140 mm
14 in × 16 in × 5.5 in

80 kgs

Polished

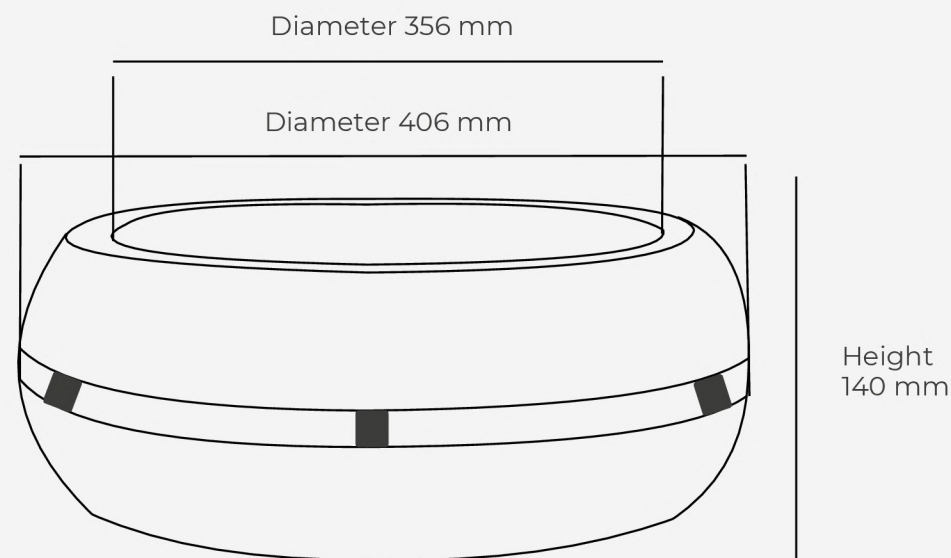

craft details

- Hand-cut marble inlay lines are individually shaped and precisely set into the vessel.
- Vertical inlays follow a restrained rhythm, aligned with the form's natural proportions and flow.
- Embedded flush within carved grooves, each element preserves seamless surface continuity.
- The form is refined post-inlay, maintaining softness, balance, stillness, and material integrity.



This edition was developed in-house at Anara, with contributions from Aishwarya Ghosh, a design student from NIFT Bhubaneswar, as part of Anara's initiative to support emerging design voices

GARBHA NIDHI



MONOLITHS

Form. Rhythm. Continuity.





S t a m b h

GROUNDED IN PERMANANCE

Inspired by India's historic pillars, Stambh translates architectural strength into sculptural monolithic forms. Rooted in rhythm, grounding, and permanence, the collection explores verticality and proportion through natural stone bases. Each piece carries a quiet architectural presence, anchoring contemporary spaces with stillness, restraint, and timeless material clarity.

FLUTED MONOLITH

The Fluted Monolith draws from India's ancient architectural pillars. Carved from natural stone, its vertically fluted surface creates a measured rhythm of light and shadow. Grounded yet sculptural, the form supports the basin with quiet permanence, expressing balance and stillness.

Available in the following sizes:

Diameter × Height

508 mm × 660 mm
20 in × 26 in

482 mm × 660 mm
19 in × 26 in

457 mm × 660 mm
18 in × 26 in

100 kgs

Polished

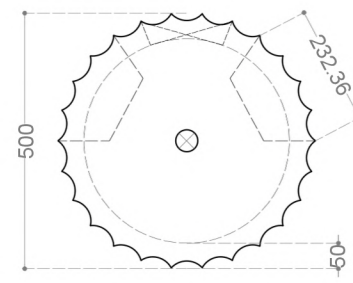

Top View

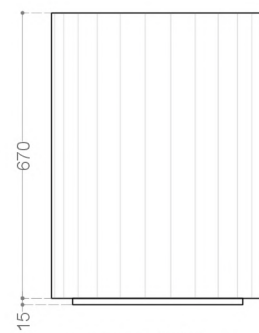

Front View

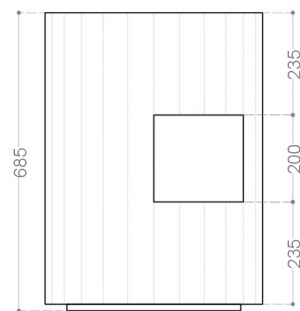

Side View

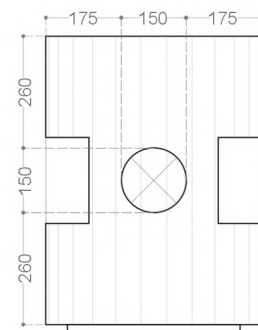

Back View

STAMBH FLUTED
MONOLITH IN
MAKRANA PINK





MAKRANA PINK
FLUTED MONOLITH



UDAIPUR GREEN
FLUTED MONOLITH



JAISALMER
FLUTED MONOLITH

STAMBH FLUTED
MONOLITH IN
UDAIPUR GREEN





STAMBH CIRCULAR
MONOLITH IN JAISALMER

CIRCULAR MONOLITH

The Circular Monolith reinterprets architectural stone forms through a pure, uninterrupted silhouette. Designed to ground the basin with permanence and stillness, the form expresses timeless strength through sculptural simplicity, proportion and its enduring material.

Available in the following sizes:
Diameter × Height

508 mm × 660 mm
20 in × 26 in

482 mm × 660 mm
19 in × 26 in

457 mm × 660 mm
18 in × 26 in

100 kgs

Polished

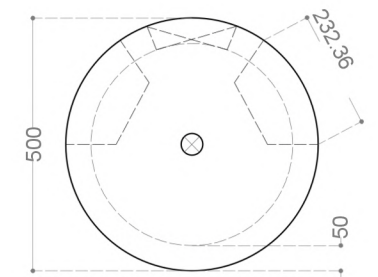

Top View

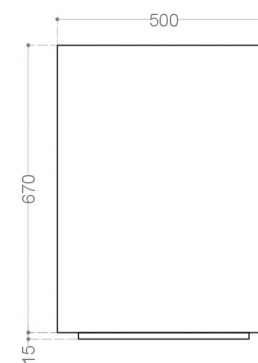

Front View

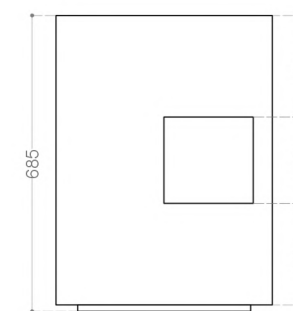

Side View

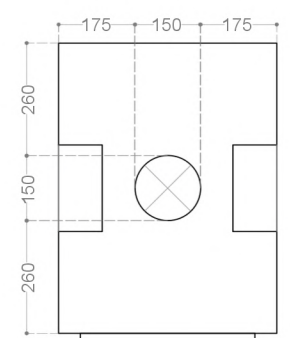

Back View



UDAIPUR GREEN
CIRCULAR MONOLITH



JAISALMER
CIRCULAR MONOLITH



MAKRANA PINK
CIRCULAR MONOLITH

Rekha

INTERSECTIONS OF FORM

Rekha draws from the language of lines as markers of rhythm, geometry, and spatial order. Inspired by traced surfaces and measured repetition, the collection reinterprets these principles through monolithic stone bases. Grid, alignment, and uninterrupted planes become restrained sculptural gestures, creating forms shaped by balance, stillness, material depth, and architectural clarity.





REKHA GRID
MONOLITH IN
UDAIPUR GREEN

GRID MONOLITH

The Grid Monolith draws from Rekha, the language of lines as markers of rhythm and continuity. Its measured grid recalls architectural mappings and traced surfaces shaped through repetition. The form becomes a restrained sculptural expression of order, balance, stillness, and spatial clarity.

Available in the following sizes:

Length × Breadth × Height

508 mm × 508 mm × 660 mm
20 in × 20 in × 26 in

508 mm × 508 mm × 660 mm
19 in × 19 in × 26 in

508 mm × 508 mm × 660 mm
18 in × 18 in × 26 in

100 kgs

Polished

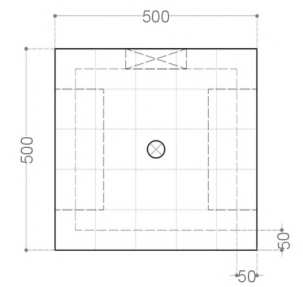

Top View

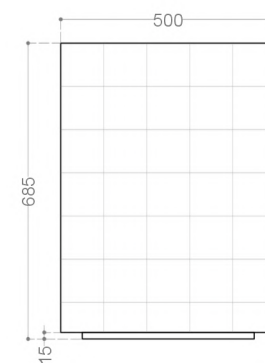

Front View

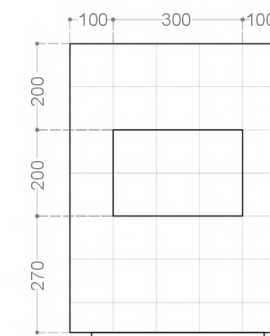

Side View

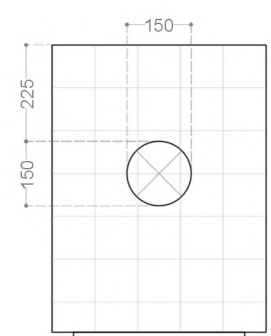

Back View



JAISALMER
GRID MONOLITH



MAKRANA PINK
GRID MONOLITH



UDAIPUR GREEN
GRID MONOLITH

REKHA GRID MONOLITH
IN MAKRANA PINK



RELIEF MONOLITH

The Relief Monolith explores Rekha through uninterrupted form and quiet proportion. Free from surface articulation, its monolithic body emphasises clarity, balance, and material depth. The form expresses stillness and permanence through restraint, allowing mass, geometry, and sculptural simplicity.

Available in the following sizes:

Length × Breadth × Height

508 mm × 508 mm × 660 mm
20 in × 20 in × 26 in

508 mm × 508 mm × 660 mm
19 in × 19 in × 26 in

508 mm × 508 mm × 660 mm
18 in × 18 in × 26 in

100 kgs

Polished

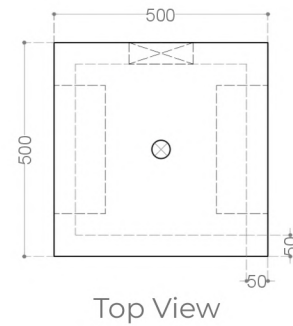

Top View

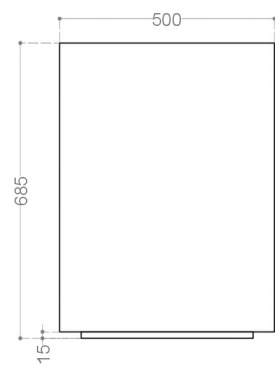

Front View

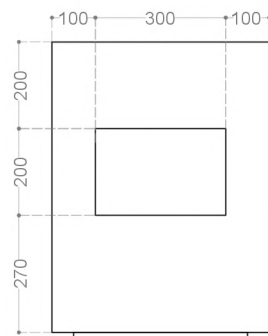

Side View

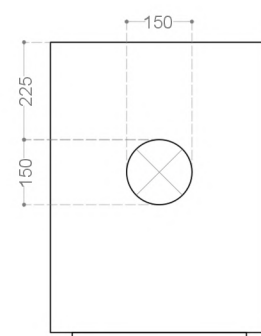

Back View

REKHA RELIEF
MONOLITH IN
JAISALMER





MAKRANA PINK
RELIEF MONOLITH



JAIASLMER
RELIEF MONOLITH



UDAIPUR GREEN
RELIEF MONOLITH

REKHA RELIEF MONOLITH
IN UDAIPUR GREEN





www.anaravessel.in / info@anaravessel.in / [@theworldofanara](https://www.instagram.com/theworldofanara)

WEBSITE



INSTAGRAM

