

Model # - SC1200

SC1200	(DxWxH)
	765x1200x1437
Water connections – 1 x Cold water for cleaning system 1 x Hot water for cleaning system only	15mm with ¾ standard hose connections Water pressure = 3 bar
Water Consumption (flow rate) Cold Water	9-11 litres per minute
Water Consumption (flow rate) Hot Water *	5-8 litres per cleaning cycle
Water connection height (mm)	150
Discharge height (mm)	207 (LEFT HANDED ONLY)
Discharge size (mm & inches)	50 / 2"
Capacity (Food Waste) per minute / hour (kg)	550kg/hr (100 litre volume)
Weight (kg)	260
Decibels (dB)	70
Electrical Phase	3
Motor voltage (v)	380-415
Motor frequency (Hz)	50
Motor kilowatt (kW)	4.8
Amps	16
Electrical Connection	Flying leads to be hard wired to site connection
Can connect to	N/A

*Hot Water supply must come from a break tank.

Version V1.0

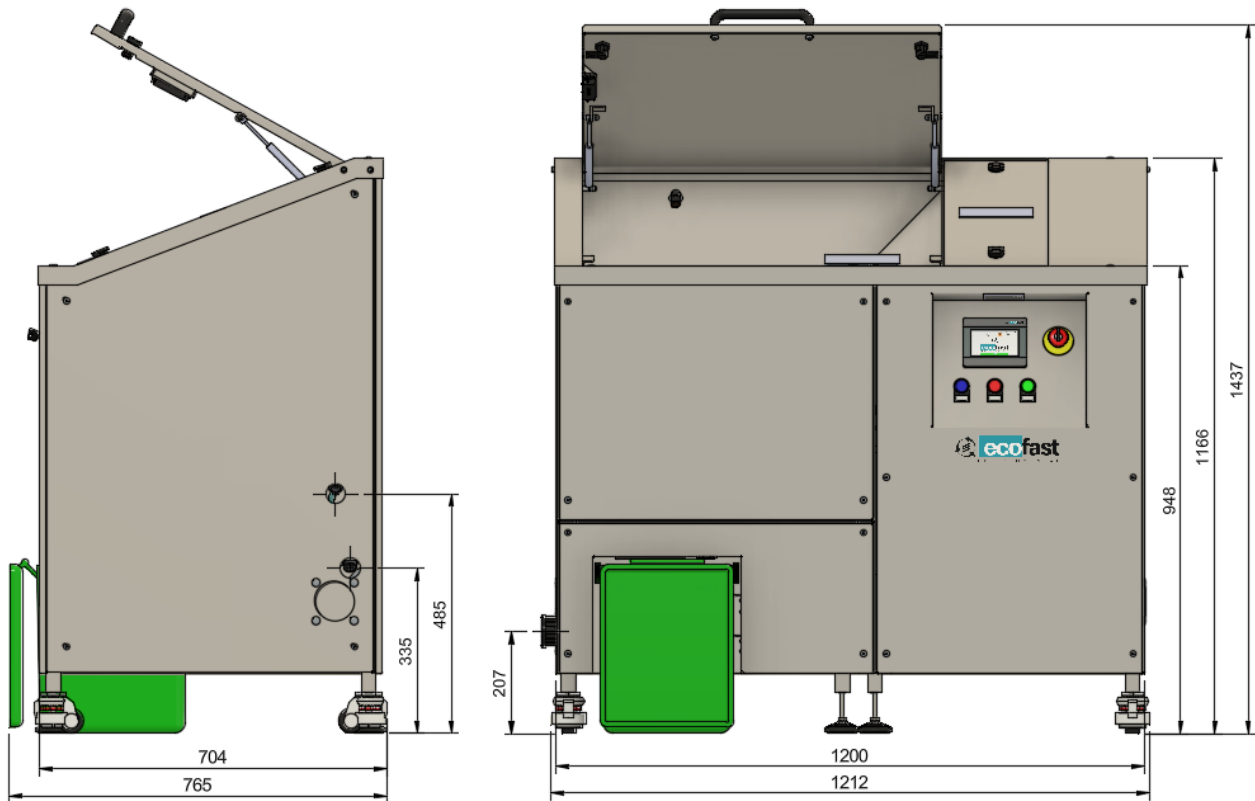