

## BLACKOUT FILM DLC 1% 20:1



Blackout Smart Film switches between tinted and clear states instantly. When power is OFF, liquid crystals and dyes (LC) absorbing light, making the film tinted. When power is ON, the liquid crystals align, allowing light to pass through for full transparency.

### ADVANTAGES



#### Fast Switching Time

Changes from clear to opaque in less than a second



#### Low Power

Consumes 6W/m<sup>2</sup> to 15W/m<sup>2</sup> when on depends on temperature



#### Ultra Clear

Transmits 21% of the visible light



#### Acoustic Insulation

Acts as a sound barrier reducing noise transmission



#### Long Lasting

Lasts over 15 years and endures 80 millions of switching cycles



#### Wellbeing

Allowing natural daylight



#### Low Haze

Maintains haze below 4%, preserving crisp views



#### Control

Certified controllers offer on/off and dimming

### WORKING PRINCIPLE

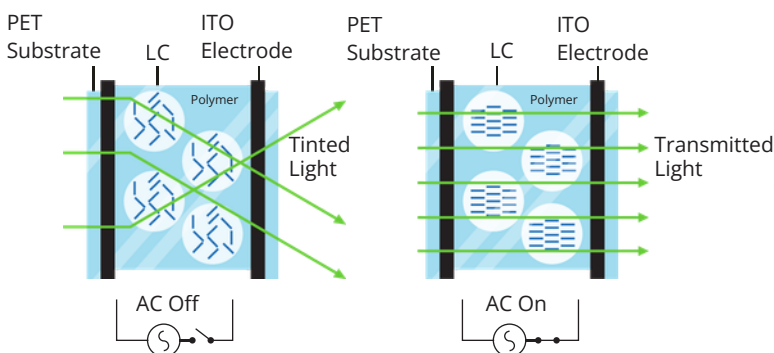

### LAYERS STRUCTURE

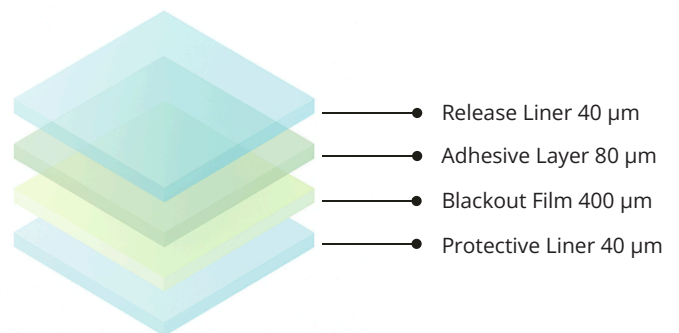

# APPLICATIONS

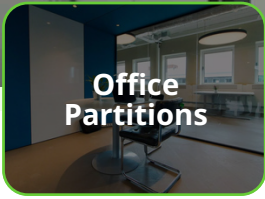

## BLACKOUT DLC 1% SPECIFICATIONS

CATEGORY	PARAMETER	STATE	BLACKOUT
<b>OPTICAL</b>	Color	ON	Transparent
		OFF	Black
	Visible Light Transmittance	ON	21% ±2%
		OFF	0.9% ±0.3%
	Haze	ON	3.0%
		OFF	100%
	Viewing Angle	ON	>120°
	UV Blocking Rate	ON	96.5%
		OFF	100%
	IR Blocking Rate	ON	15.8%
OFF		97.7%	
<b>ELECTRICAL</b>	Controller Input Supply		110V / 220V AC
	Working Operating Voltage	ON	48V AC 50Hz
	Response Time	ON -> OFF	10-150 ms
	Response Time	OFF -> ON	10-50 ms
	Durability	ON	> 8 years
	Power Consumption	ON	6-15 W/m <sup>2</sup> /h (0.56-1.39 W/Sq. F)
	Operating Modes		On, Off, Dimming
<b>MECHANICAL</b>	Width		1000mm (39"), 1200mm (47") 1500mm (59") or custom
	Roll Length		30m (≈100 ft) 50m (≈165 ft)
	Thickness		480 μm
	Formats		Cut to Size , Roll
	Available Colors		Black
	Compliance		Company: ISO9001, IATF16949 Products: RoHS,CE, UL
<b>ENVIRONMENTAL</b>	Storage Conditions		-20°C~ 60°C (-4°F ~ 140°F) 20%-60% humidity
	Working Temperature		-20°C~ 90°C (-4°F ~ 194°F)