

# EVOS Fleet22

Installation Manual - Australia

# Contents

<b>QUALIFICATIONS</b>	<b>3</b>
<b>PRODUCT SPECIFICATION</b>	<b>4</b>
COMMUNICATION	4
COMPLIANCE	4
CONNECTOR	4
ELECTRICAL	4
ENVIRONMENTAL	4
LOGISTICS	4
PHYSICAL	4
<b>INSTALLATION PREPARATION</b>	<b>5</b>
<b>IN THE BOX</b>	<b>5</b>
<b>ELECTRICAL SAFETY</b>	<b>6</b>
<b>SUPPLY WIRING</b>	<b>6</b>
1 PHASE INSTALLATION	6
3 PHASE INSTALLATION	6
<b>INSTALLATION</b>	<b>7</b>
<b>TOOLS</b>	<b>7</b>
<b>LOCATION</b>	<b>7</b>
<b>COMPONENT GUIDE</b>	<b>8</b>
<b>INSTALLATION STEPS</b>	<b>8</b>
1. REMOVE SHIELD FROM STATION	8
2. MARK FIXING POINT	9
3. MOUNT STATION BASE	9
<b>4. OPTION A</b> - LOOSE QUICKON CONNECTOR	9
<b>4. OPTION B</b> - TERMINATED QUICKON CONNECTOR WITH 1M CABLE	8
5. CONNECT QUICKON CONNECTOR TO THE CHARGER	10
6. CONNECT CHARGING CABLE	10
7. REGISTER AND CONFIGURE (MANDATORY)	11
8. INSTALL SHIELD	13
9. POWER ON	13
10. ELECTRICAL TESTS	13
11. TEST CHARGE	13
<b>USING FLEET22</b>	<b>14</b>
<b>CHARGER STATUS INFORMATION</b>	<b>15</b>
<b>WI-FI SETUP PROCESS (OPTIONAL FOR FLEET22)</b>	<b>16</b>
<b>CHECKLIST</b>	<b>17</b>

# Qualifications

- ❗ The EVOS Fleet22 is designed to only be connected to a dedicated AC supply.
- ❗ The EVOS Fleet22 requires only Type A RCD + MCB upstream protection.
- ❗ The use of adapters or conversion adapters are not permitted with EVOS Fleet22.
- ❗ The use of cord extensions are not permitted with EVOS Fleet22.
- ❗ EVOS Fleet22 initial installation must be performed by a qualified electrician.
- ❗ EVOS Fleet22 must be installed according to local regulations (AS3000).
- ❗ Ventilation function is not supported by EVOS Fleet22.
- ❗ Upstream power must be isolated before insertion or removal of the QUICKON connector.
- ❗ Upstream power must be isolated before insertion or removal of the charging cable.

# Product Specification

## Communication

Charging Mode	3
Protocol	OCPP 1.6
Wired	Ethernet 10/100Mbit
Wireless	Wi-Fi: 2.4GHz IEEE 802.11.b/g/n Bluetooth: 4.1 Optional: LTE CAT-M1

## Compliance

Certification	CE Certified, CB Certification
Protection Class	I
Standards	IEC 61851-1, IEC 61851-21-2 EU RoHS Directive Compliant

## Connector

Charging Cable length	5m (optional 6m). Other lengths optional
Charging Connector Type	Type 1 (SAE J1772 / IEC 62196 Type 1) Type 2 (IEC 62196 Type 2)

## Electrical

Charging Power	7.4kW (1P max) or 22kW (3P max) at 230V
Connection Method	Permanently connected
Ground	PE Cable
Input power supply characteristics	EV supply equipment connected to AC supply network
Input voltage (L-N)	110 to 230 V AC
Maximum Output Current	32 Amps per outlet
Nominal AC Frequency	50 Hz / 60 Hz
Output power supply characteristics	AC EV supply equipment
Protection	6mA DC RCD - Only Type A RCD + MCB upstream protection required

## Environmental

Access Condition	Unrestricted Access
Altitude	Up to 2000M
Impact Protection	IK10
Ingress Protection	IP65
Operating temperature	-25° C to +55° C
Relative humidity	Maximum 95% non-condensing

## Logistics





Storage temperature	From -30°C to 85°C
Packing weight	8.2kg
Packing Dimensions (L x W x H)	530 x 510 x 200mm

## Physical

Colour	Piano Black
Dimensions (W circular x H)	380 x 100mm
HMI	Status LED with dedicated apps
Mounting Height	Minimum 900mm from lowest edge to floor level
Mounting Type	Wall
Weight (including cable)	6.5kg

# Installation Preparation

## In the Box

Item	Description	Image	Qty
1.	Fleet22 Charger		1
2.	Decorative Cover		1
3. (Optional)	Packet of M5 Countersunk Screws + M3 Security Bit		1
4.	Power Input Cable - Terminated		1
	or		
4.	QUICKON Connector		1
5.	Charger Adoption Key		1

## Supply Wiring - Input Connector

One of two options may be provided with the Fleet22.

### OPTION A.

Phoenix QUICKON Nut	
Conductor Size	2.5mm <sup>2</sup> ... 6mm <sup>2</sup>

Typical installation will use a 6mm<sup>2</sup> 4C+E heavy duty flex cable.

Installation guide can be found on the Phoenix Contact Website  
Choose “Downloads”, then “Package Slip”

<https://www.phoenixcontact.com/en-au/products/installation-pressure-nut-qpd-n-4pe60-12-20-bk-1410406>

Example Installation Video

<https://www.youtube.com/watch?v=nC7tI9qDsFA>

### OPTION B.

A 1.1M, 6mm<sup>2</sup> 4C+E heavy duty flex cable, terminated into a QUICKON connector.

# Installation Preparation

## Audience

This document is intended for consumption by licenced electricians.

## Electrical Safety

Upstream protection must be installed for safe operation.

<b>Required Upstream Protection</b>	1 Phase Installation	<ol style="list-style-type: none"> <li>1. Only type A RCD (as per AS3000) Recommended 30mA Type A</li> <li>2. MCB (as per AS3000) Recommended Type C MCB 40A</li> </ol>
	3 Phase Installation	<ol style="list-style-type: none"> <li>1. Only type A RCD (as per AS3000) Recommended 30mA Type A</li> <li>2. MCB (as per AS3000) Recommended Type C MCB 40A</li> </ol>

## Supply Wiring

Where multiple stations are connected to the same three phase supply, it is recommended to rotate L1, L2, L3 input phases to prevent overloading.

### 1 Phase Installation

Only one phase (L1, L2 or L3) may be connected to L1 designation on input connector.

Neutral (N) and ground (G) must be connected to designation on input connector.

The phase voltage must measure ~230V to neutral.

**!** L2 or L3 designation on input connector cannot be used for 1 phase installation.

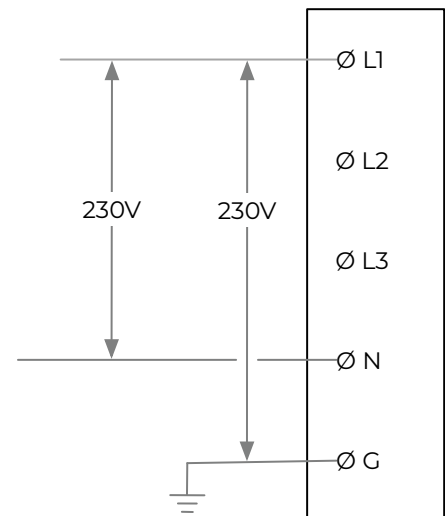

### 3 Phase Installation

All three phases (L1, L2 and L3), Neutral (N) and Ground (G), must be connected to corresponding designation on the input connector.

Each phase voltage must measure ~230V to neutral.

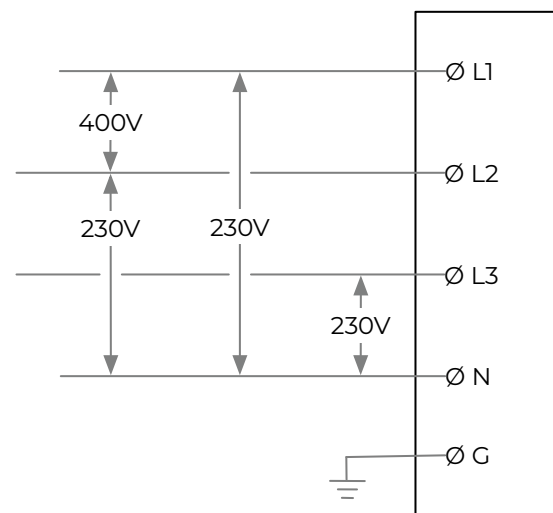

## Typical Installation Example

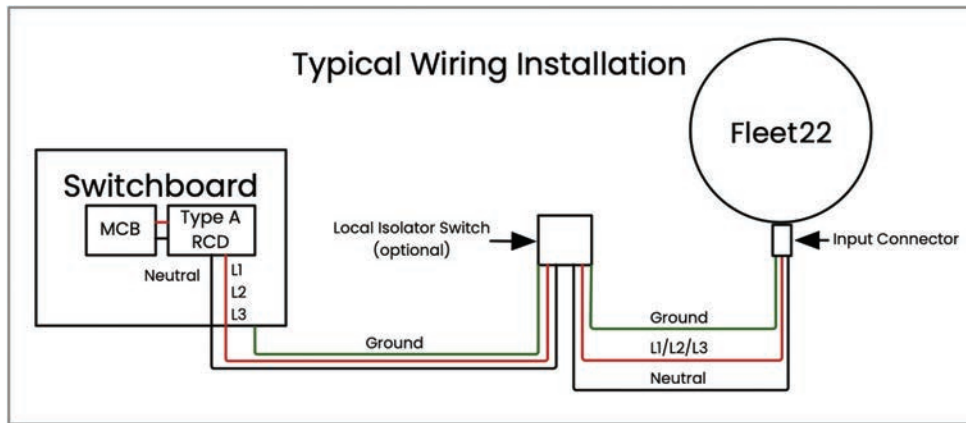

# Installation

## Tools

- 1 x Power Drill
- 1 x M4 Drill Bit
- 1 x Phillips Head Screw Bit
- 1 x 3mm Post Hex Security Bit
- 1 x Standard Electrical Test Equipment
- 1 x Level
- 1 x Mobile Phone or Laptop with Wi-Fi for Commissioning

## Location

Before installation, check the preferred installation location has these features

1. Easy access by driver
2. Easy stowage of charging cord (prevent wheel crush damage)
3. Easy to plug in vehicle without straining cable
4. Station is protected from vehicle damage
5. Station lower edge mounting height is minimum 900mm from floor level.

**Component Guide**

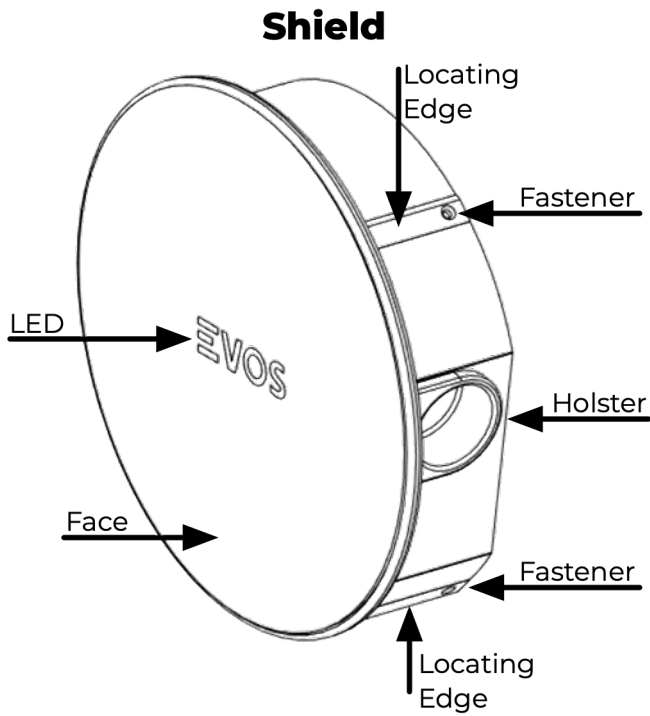

**Charging Cable with Type 1 Plug**

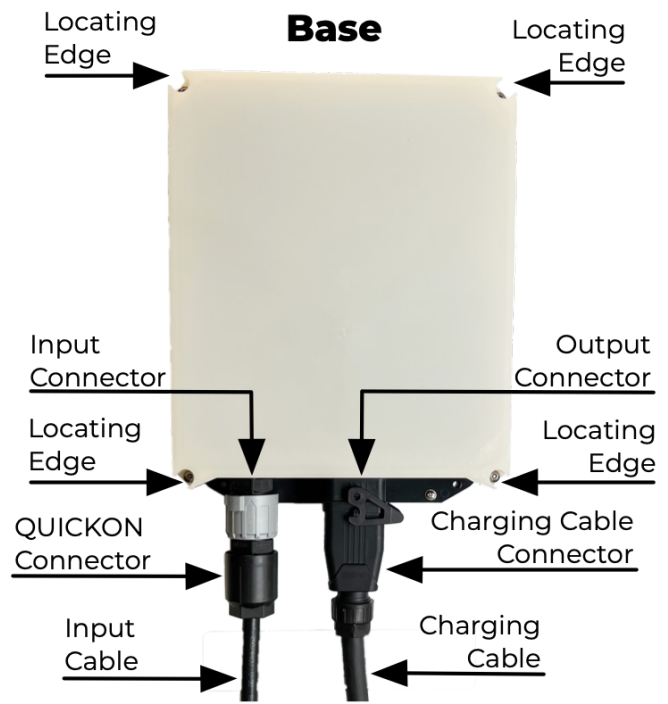

**Charging Cable with Type 2 Plug**



**Installation Steps**

Please check off the items on the checklist located on the last page of this document.

**1. Remove shield from station (if secured).**

Remove the 4 x M5 fasteners that secure the shield to the base using a 3mm Hexagonal Security Bit.

Place fasteners aside for re-installation.

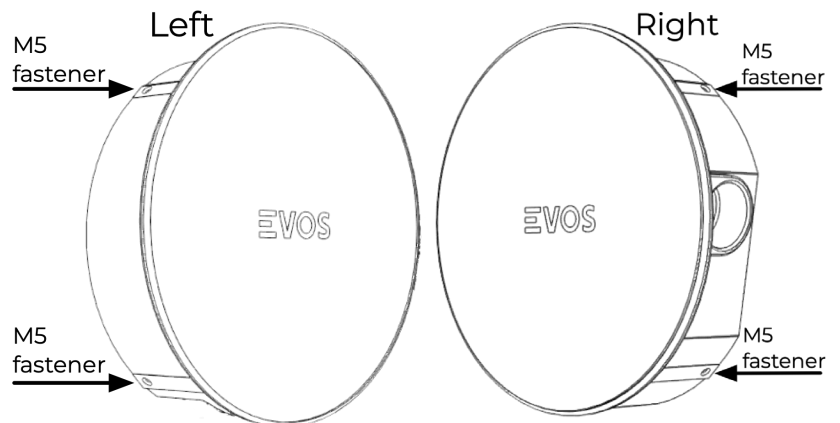



(1) Slide the shield away from the base.

Place the shield face up where it will not be marked, scratched or damaged.

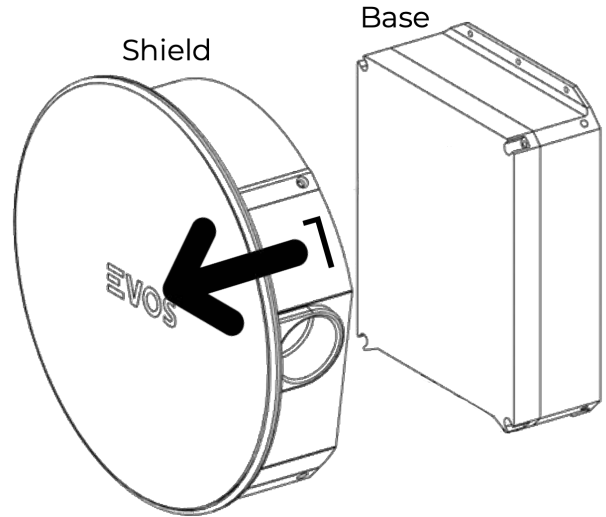

**2. Mark fixing point**

Use a level across the top of the base unit to level and use the provided measurements of the image (right) to mark fixing points on the mounting surface.

! Minimum height of the lower edge is 900mm from floor level

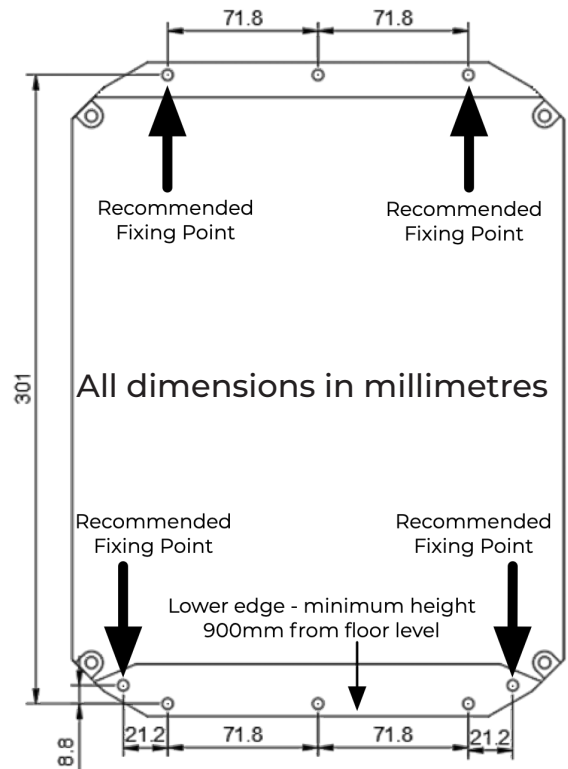

**3. Mount station base**

Use size M4 fasteners (supplied) to fix the station to mounting surface. Do not exceed 5 Nm when installing fasteners

**4-A. For Option A - Loose QUICKON Connector.**

(Referring to Installation Preparation and Supply Wiring - Input Connector on page 5)

**Terminate AC Input cable**

Strip 60mm off outer sheath

Wrap earth cable around live conductors

Expose splice body - Hold QUICKON Nut and screw splice body anticlockwise until designations are visible - do not use tools.

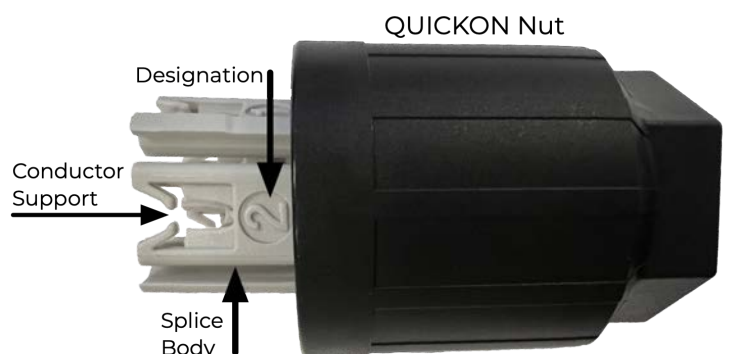

Confirm wiring conductor size is within limits of the QUICKON Nut specifications.  
 Fix wires in conductor supports of the splice body corresponding with the L1, L2, L3, N and PE designation.

Cut off excess wire flush to splice body

Align white line of QUICKON connector with the black line of the splice body in QUICKON Nut

Tighten QUICKON Nut as far as it will go by hand.

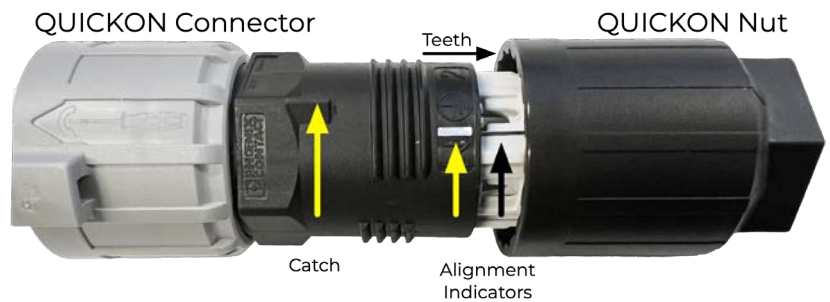

Hold the QUICKON connector with your hand and use a tool to turn the QUICKON Nut until you feel mechanical latching.

Check the QUICKON nut is not removable by hand.

Check continuity of L1, L2, L3, N and PE contacts of the QUICKON connector.

Perform an adequate pull test to confirm the connection is acceptable.

Example Installation Video - <https://www.youtube.com/watch?v=nC7tl9qDsFA>

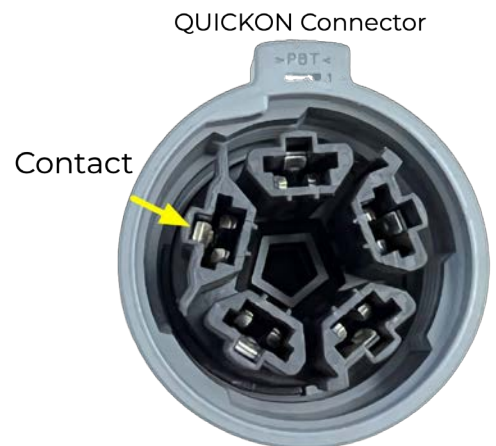

**4-B. For Option B - Terminated QUICKON Connector with IM cable.**

Install a power termination box / switch close to the charger.  
 Connect the Terminated QUICKON Connector and cable to the termination box/switch.

**5. Connect QUICKON Connector to the charger.**

(1) Twist the grey collar of QUICKON connector to far left. Collar will rise slightly and click in place.

Locate white indicator on station inlet

Orient Leverage Point and Arrow on the grey collar of QUICKON connector to the left side of the white indicator on the input connector.

(2) Slide QUICKON connector upwards as far as it will go.

(3) Twist the grey collar of QUICKON connector to the right until the locking tooth of the leverage point clicks over the catch.

If the grey collar does not twist to the right, the connector is not fully inserted.

**!** Do not proceed until connector is secure.

The QUICKON connector has dangerous voltages present when upstream power is enabled. The connector should not be removable by hand.

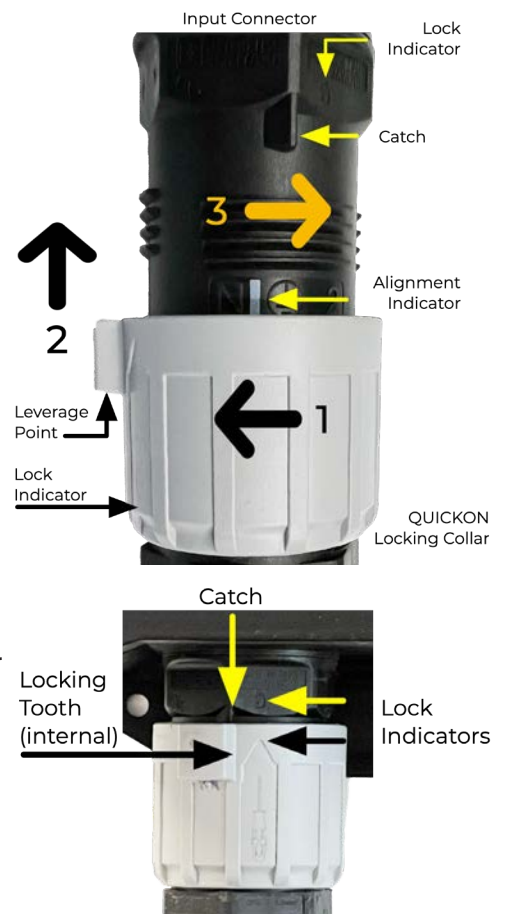

## 6. Connect charging cable

- (1) Swing the retaining clip upward.
- (2) Insert charging cable inlet into the station outlet until it is snug.

If the inlet does not engage, turn it 180° and try again.

- (3) Swing the retaining clip downwards until the retaining clip snaps in place.

**!** Do not proceed until the connector is secure.

The station output connector has dangerous voltages present when a vehicle is charging.

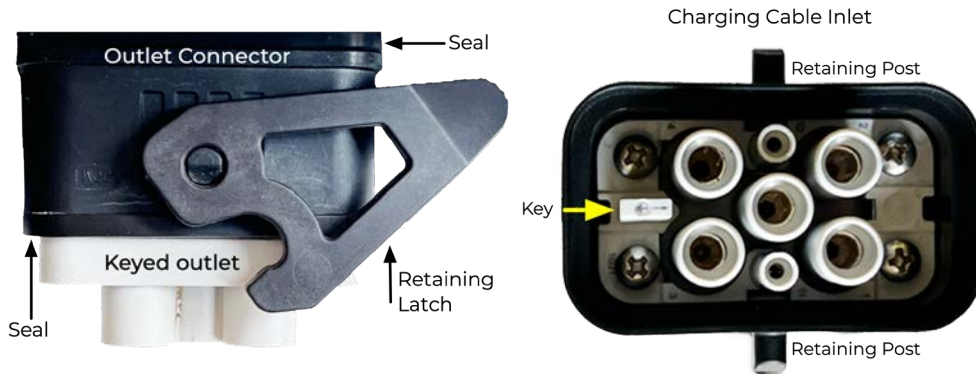

## 7. Register and configure (Mandatory)

Connect to the EVOS App using your mobile phone, scan the QR code on the base and register the station. If the QR code does not work, enter this URL into a browser.

<https://evos.app/c/<serial>>

### Example

<https://evos.app/c/123456>

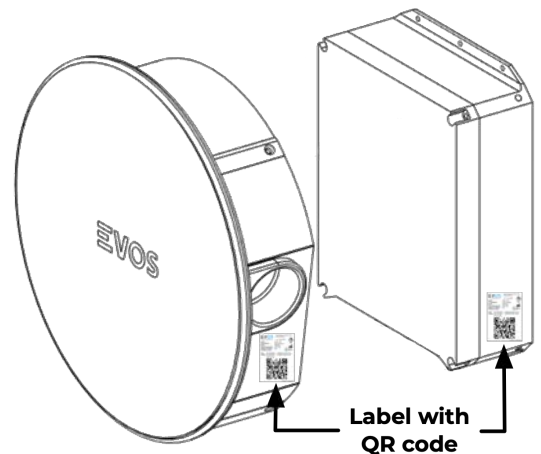

## 7. Register and configure (Mandatory)

If you have an installer account, please sign in, otherwise register an account.

### Sign In

Enter your username and password, then click “Sign In” (1) to access the EVOS App.

### Register

Click “Register” (2) to create a login for the EVOS App as an Installer.

### Reset Password

Click “Forgot your password?” (3) to reset your password

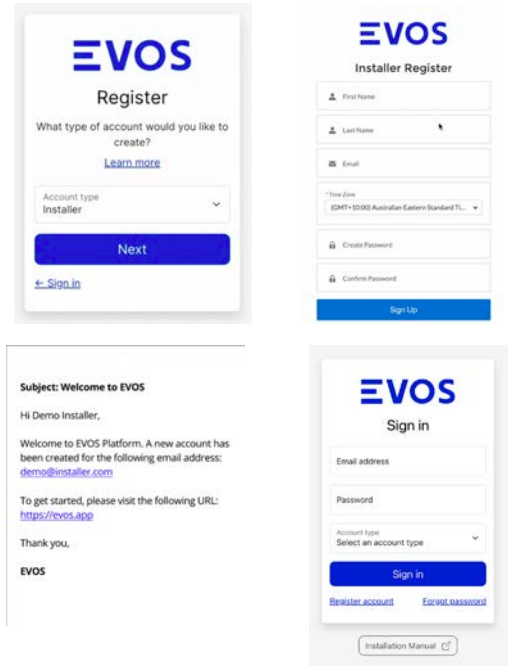

### Electrical License

At the install screen, please enter

1. Your electrical license number
2. Your electrical license type
3. Your electrical license expiration date
4. Which country is this license for
5. Which state or territory is this license for.



### Commission Charger

At the install screen, please enter

1. The charger serial
2. The address where the station is installed.
3. The “Circuit Amperage Limit”.  
This value represents the maximum continuous amperage the station may draw from the local circuit.  
**NOTE.** The default circuit amperage limit is set to 32A. This value **MUST** be verified / adjusted by the installation electrician at the time of installation.
4. Owner’s email address. This will send an email to the owner of the charger to adopt it and configure the Wi-Fi network.
5. Take/upload 3 photos of the installation that show: The Charger, Compliance label, Residual-current device

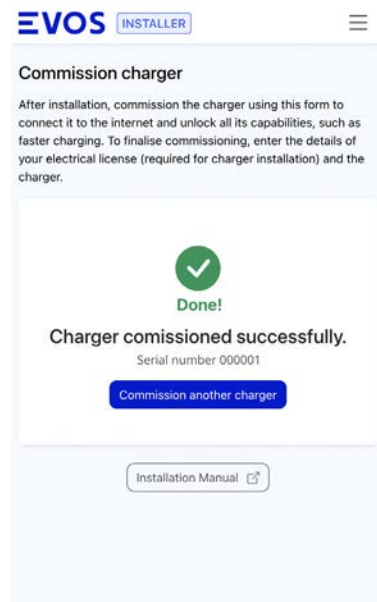
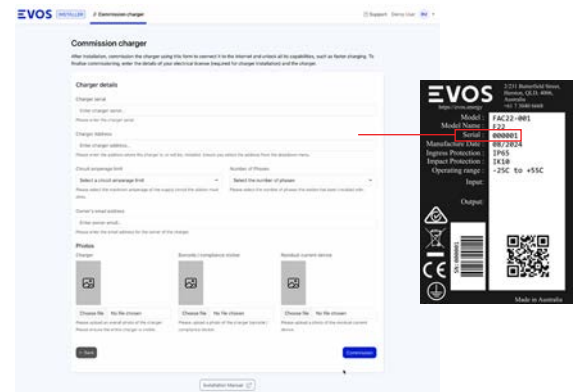

The successful install screen will be displayed on configuration.

If unsuccessful, please call +61 7 3543 0064.

### 8. Install Shield

Align the shield with the docking port facing the right-hand side.

Slide the shield over the four locating edges of the station base.

Shield should gently slide until flush.

Use the 4 x M5 fasteners saved in step 1 or found in the enclosed plastic bag to secure the shield to the station base using a 3mm Hexagonal Security Bit.

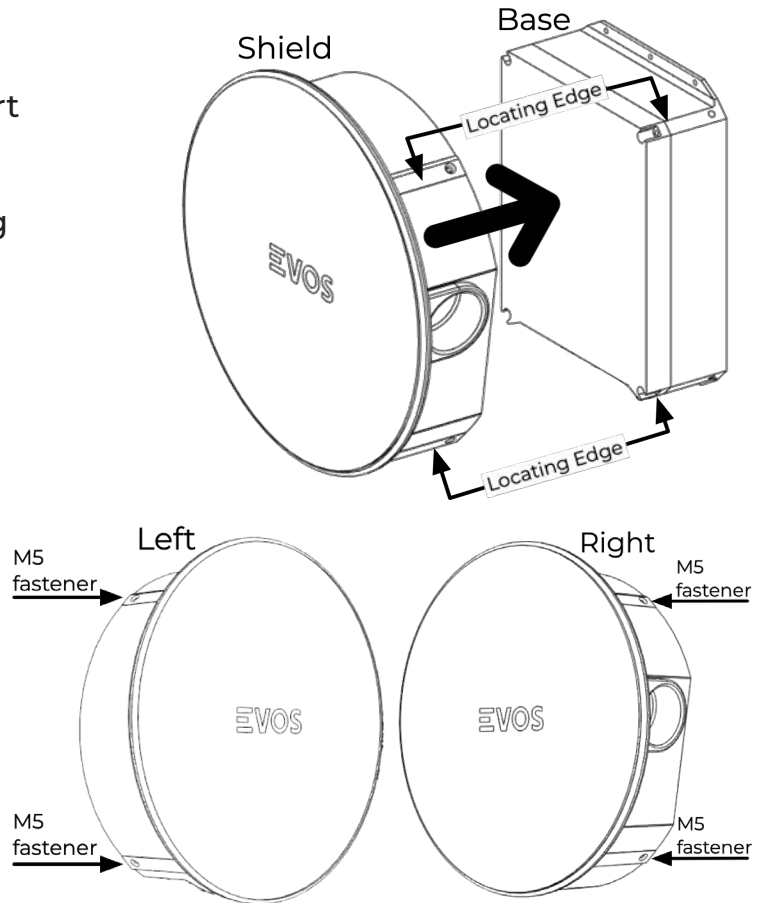

### 9. Power ON

Enable the upstream power

### 10. Electrical Tests

Perform all required electrical tests

### 11. Test Charge

1. Connect a vehicle and perform a test charge.
2. Recommended to use a thermal camera to verify there are no hot spots on the input connector.

# Using Fleet22

## Charging a Vehicle

1. Check EVOS Fleet22 status LED is White.
2. Follow vehicle preparation instructions for starting a charging session (unlock inlet / open door / remove inlet cover).
3. Remove the plug from the holster or remove the protective cap.
4. Check the charging cable for damage and the plug for damage or contamination.
5. Insert the plug into the vehicle inlet. Check the plug is fully inserted.
7. Start of charging session, check EVOS Fleet22 status LED is Blue.  
(Charger Status Information in the next page.)
8. When the charging session ends, follow the vehicle instructions to unlock the vehicle inlet.
9. Remove the plug from the vehicle inlet.
  - ⚠ Never use force to remove the plug.
10. Loop the cable once anti-clockwise around the shield and place the plug in the holster or replace the protective cap immediately.
11. Check Fleet22 status LED is White.
12. Follow vehicle instructions after charging session (install covers / close door)

## Charger Status Information

The LEDs on the EVOS Fleet22 convey the state of the station as listed below.



**White**

Charger is ready for charge.



**Blue Slow Pulse**

Charger waiting for authentication. Press 'Start Charge' to begin charging.



**Blue**

Charger is charging.



**Red**

Charger is faulted.



**Red Slow Pulse**

Charger is unavailable.



**Green, Off Pulse**

Vehicle not ready. Check vehicle for more details.



**Cyan, White Pulse**

Charger is not connected to Internet.



**Green, White Pulse**

Unplug charging cable and plug again.



**Red, Purple, White, Green**

Charger is rebooting from a hard reset.



**Purple, Cyan Pulse**

Downloading.



**Blue Quick Flashing**

Charger is suspending.



**White with Loading Spinner**

EVOS App is sending a start, pause or resume command to the charger. (EVOS App)

# Wi-Fi Setup process (optional for Fleet22)

## 1) Register a new MyEVOS account and adopt an Fleet22 charger

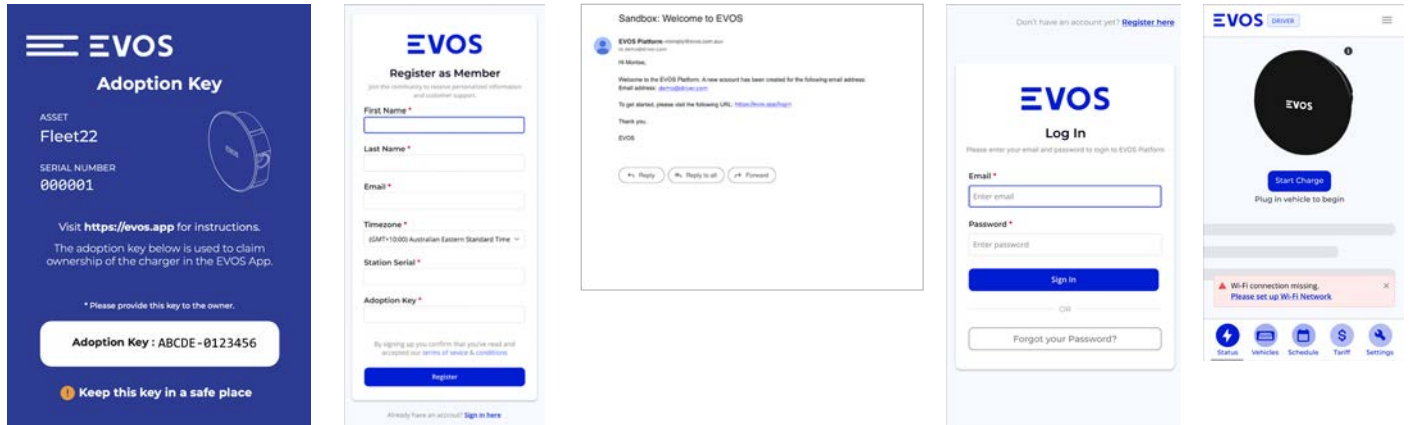

## 2) Set up Wi-Fi using your Home Wi-Fi credentials

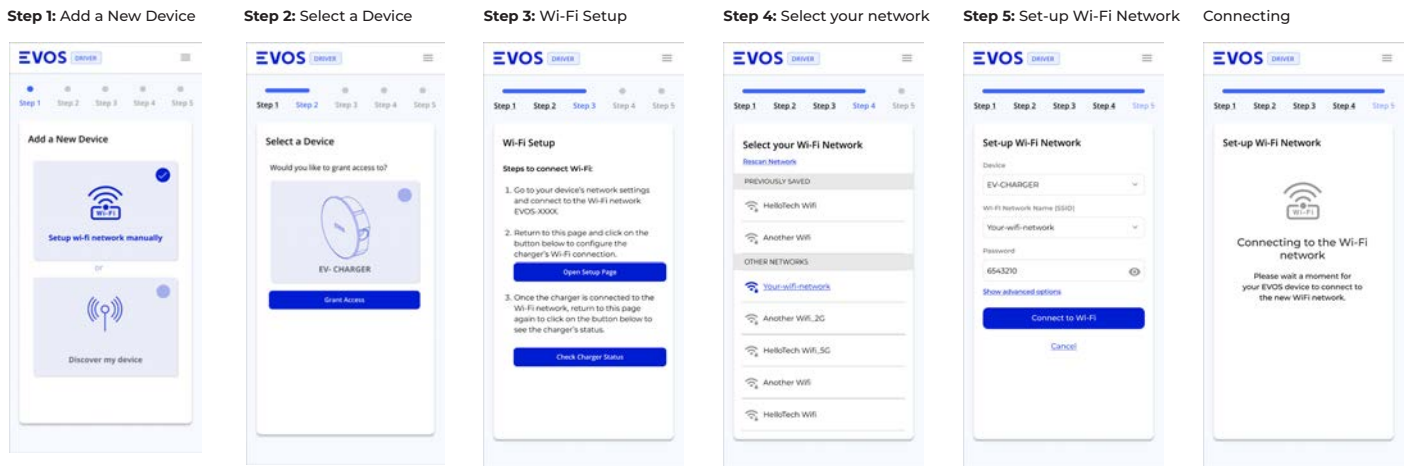

## 3) Your Fleet22 is now connected to Wi-Fi and you can unlock all its capabilities.

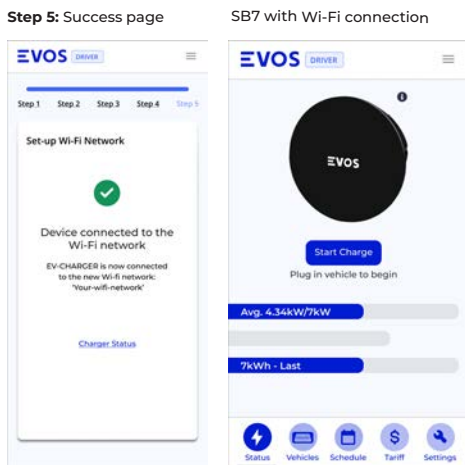

**Wi-Fi connection missing. Please set up Wi-Fi Network**

If your charger didn't connect successfully to the Wi-Fi, the App will show this alert, also the charger will blink with a white and cyan light. Please check your Wi-Fi is enabled, the credentials are correct, and try again from Step 1.

**White, Cyan Pulse**  
Charger is not connected to Wi-Fi.



# EVOS Support

If you require support during your installation, we're happy to help.  
 Please call +61 7 3543 0064.  
 For general email enquiries, [sayhi@evos.com.au](mailto:sayhi@evos.com.au)

## Checklist

Please use this checklist to ensure the station has been installed safely.

Item	Yes	No	Comment
Station base, shield and charging cable are not damaged			
Station mounting position is easy to access			
Station mounting position is protected from vehicle damage			
Station lower edge above 900mm above ground level			
Upstream type A RCD installed			
Upstream type C MCB installed			
Station base is mounted securely to surface			
QUICKON Nut is secure and not removable by hand			
QUICKON connector is secure and not removable by hand			
Charging cable is secure and not removable by hand			
Circuit amperage limit has been set			
Shield is mounted flush and secured with 4 x M5 fasteners			