



# SMART FILM

## PNLC ADHESIVE WHITE

Adhesive Polymer Network Liquid Crystal (PNLC) smart film switches between opaque and clear states instantly. When power is off, the crystals align, allowing light to pass through for full transparency. When power is on, liquid crystals (LC) scatter light, making the film opaque.

### ADVANTAGES

**Fast Switching Time**  
Changes from clear to opaque in less than a second

**Low Power**  
Consumes less than 5W/m<sup>2</sup> when on

**Ultra Clear**  
Transmits 88% of the visible light

**Acoustic Insulation**  
Acts as a sound barrier reducing noise transmission

**Long Lasting**  
Lasts over 15 years and endures 80 millions of switching cycles

**Wellbeing**  
Allowing natural daylight

**Low Haze**  
Maintains haze below 10%, preserving crisp views

**Control**  
Certified controllers offer on/off and dimming

### WORKING PRINCIPLE

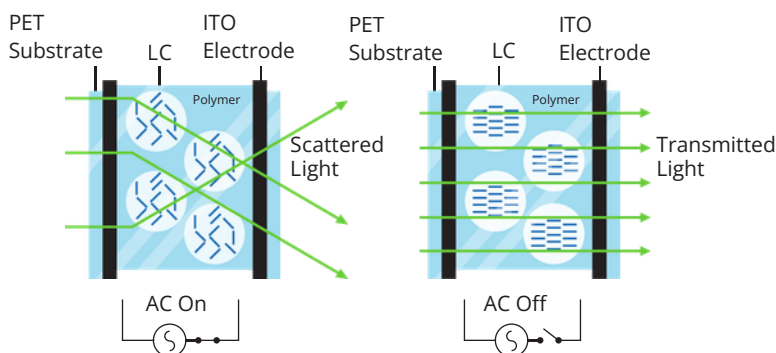

### LAYERS STRUCTURE

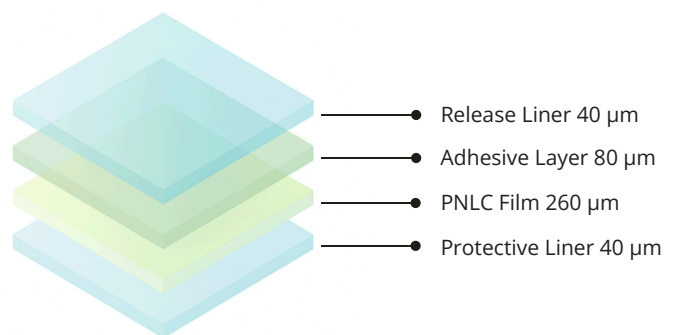

# APPLICATIONS

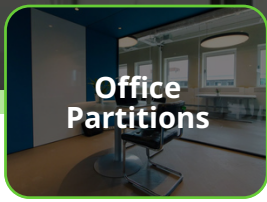

## PNLC SMART FILM ADHESIVE WHITE SPECIFICATIONS

CATEGORY	PARAMETER	STATE	PNLC
OPTICAL	Color	ON	Opaque White
		OFF	Transparent
	Visible Light Transmittance	ON	88%
		OFF	9%
	Parallel Light Transmittance	ON	80%
		OFF	7%
	Haze	ON	10%
	Viewing Angle	ON	> 160°
	UV Blocking Rate	ON	99.6%
	SHGC	ON	N/A
OFF		N/A	
ELECTRICAL	Controller Input Supply		110V / 220V AC
	Working Operating Voltage	ON	48-65V AC
	Response Time	ON -> OFF	500 ms
	Response Time	OFF -> ON	500 ms
	Switching Times		> 80 million Times
	Durability	ON	> 15 years
	Smart Film Power Consumption	ON	< 5 W/m <sup>2</sup> /h (<0.45 W/Sq. F)
	Controller Power Consumption		2-4 W/m <sup>2</sup> /h (0.19-0.37 W/Sq. F)
Operating Modes		On, Off, Dimming	
MECHANICAL	Width		1200mm (47"), 1450mm (57")
	Roll Length		30m (≈100 ft) 50m (≈165 ft)
	Formats		Cut to Size, Roll
	Available Colors		White
	Compliance		Company: ISO9001, IATF16949 Products: RoHS,CE, UL
ENVIRONMENTAL	Storage Conditions		-20°C~ 60°C (-4°F ~ 140°F) 20%-60% humidity
	Working Temperature		-10°C~ 60°C (14°F ~ 140°F)