

Solid core fender

Material: Inner core from Eva foam, Outer layer from Orca® fabrics

2000001519

Description

Solid core fenders are custom made to perfectly match the style of your yacht.

Solid core fenders are made from closed cell EVA foam which is a highly refined grade of environmentally friendly material.

It is robust, has a great shockproof performance, and has no water absorption. The foam is covered with hypalon of which a variety of colours and textures are available to your taste.



Isometric view

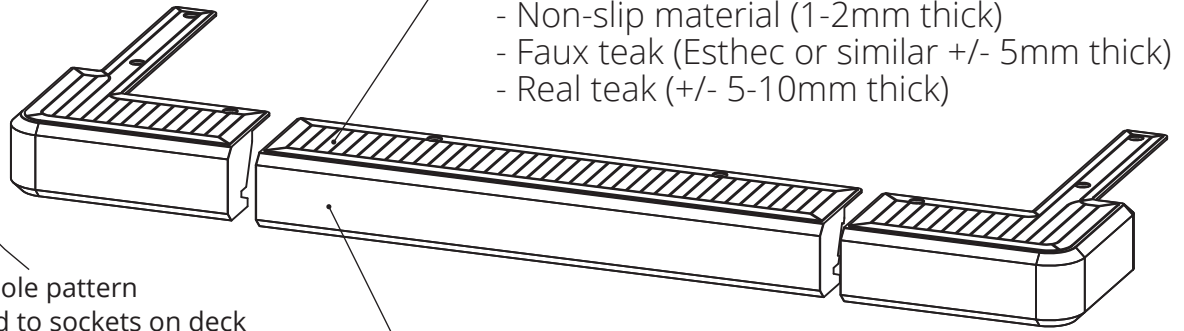

- Options for non slip area / walking area
- Non-slip material (1-2mm thick)
 - Faux teak (Esthec or similar +/- 5mm thick)
 - Real teak (+/- 5-10mm thick)

Outer layer - Orca®, by Pannel & Flipo
Available in 6 standards, 38 different colours and 6 surface finishings.

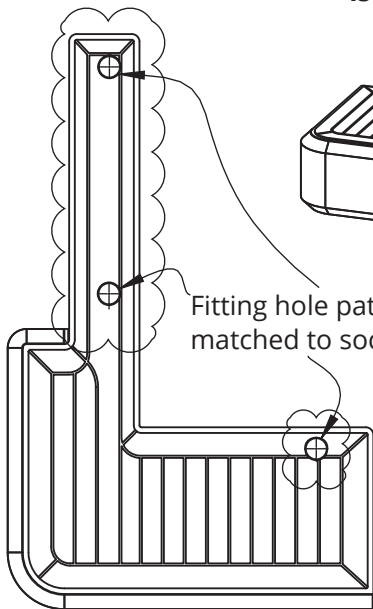

Fitting hole pattern matched to sockets on deck

Topview

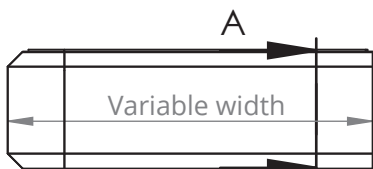

Frontview

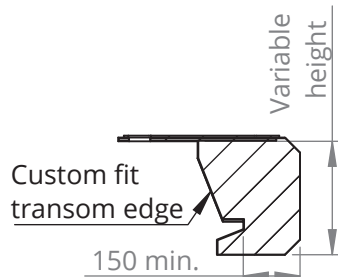

Detail cross section A-A

Xquip M12 Cup deck
2000000128
(needs to be installed on corresponding locations !)

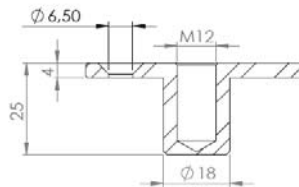
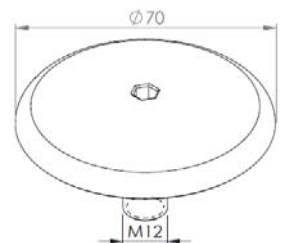

Plate cover Ø70 M12
2000002536



Xquip appendix material options for Solid core fenders

(=Horizontal foam block fenders)

Matrix with recommended materials per application

	Main Cladding	Non slip area
hypalon smooth (regular)	++	X
Perlage structure	+	++
Carbon structure	++	+
Fabric impression	X	+
Teak real/fake (+ 5mm)	X	++

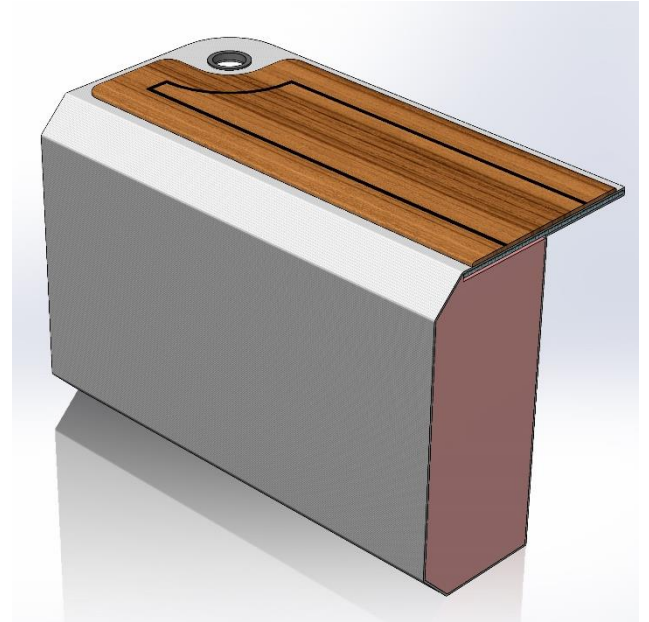

Options for non slip area/ walking patch

1 Non slip material, applied during production (1-2mm thick)

2 Fake teak (Esthec or similar, ~5mm thick)

will not exactly match with yacht and over time age different than real teak

A applied during production, simplified pattern

B applied by 3rd party after production, planking pattern can be aligned with transom deck

3 Real teak (Thickness ~5-10mm TBD)

A applied during production, simplified pattern, not exact material match

B applied by 3rd party after production, planking pattern and material can be matched with yacht

C applied by same supplier as yacht teak planking pattern and material can be matched with yacht

standard Pricing, Leadtimes:

Option **1** is standard included in quote/ production

Option **2A, 3A** simplified pattern can be included in quote/ production

additional Pricing, Leadtimes:

Option **2B, 3B** pricing + leadtimes TBD depending on exact requirements from Client

Option **3C** not included, but of course we can support as much as possible with drawings etc. if needed.

Material type and colours, see next page>>

